

Manufacturer Of all kind of General Surgical Instruments

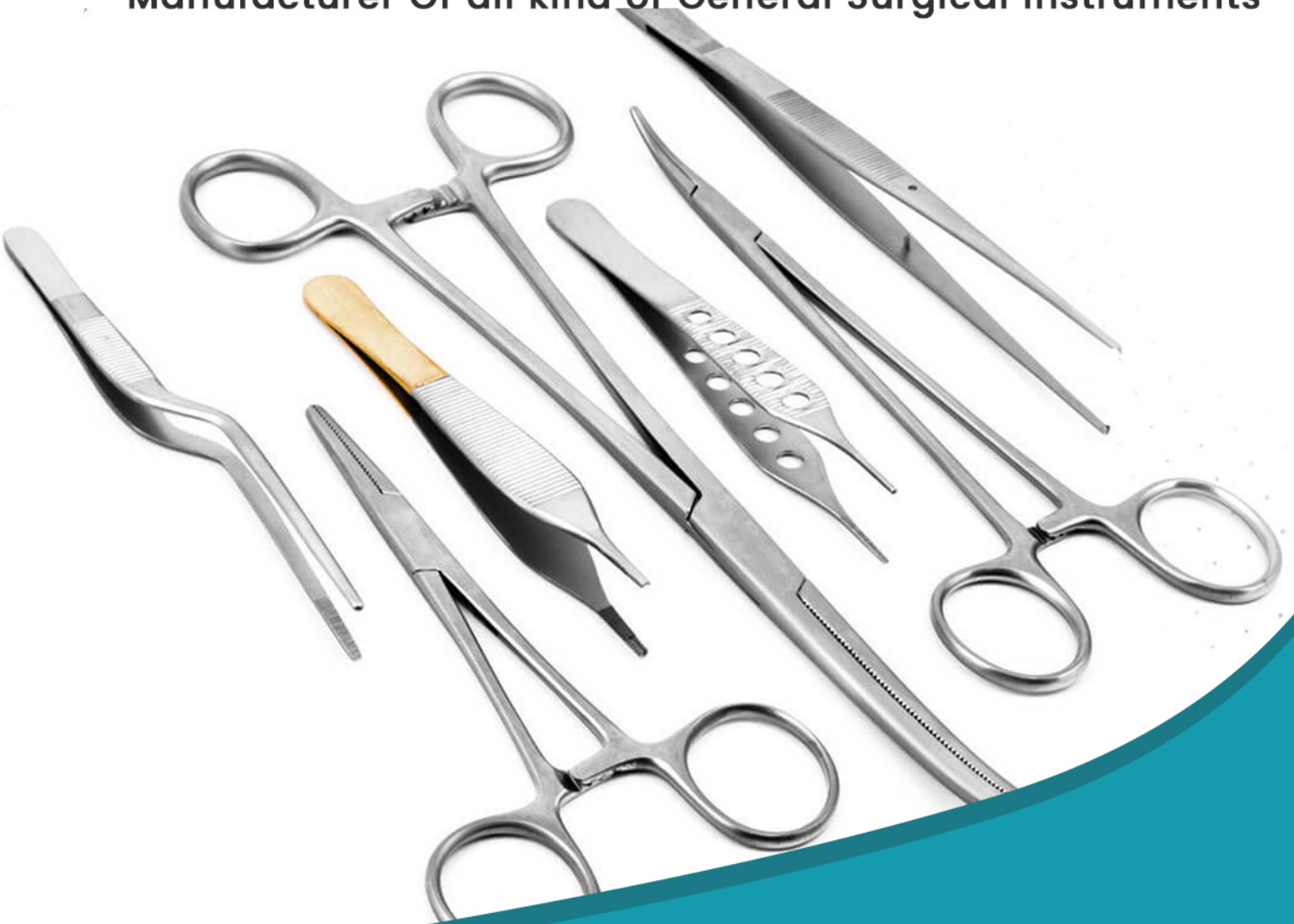

# PRODUCT CATALOG

## GENERAL SURGICAL INSTRUMENTS



# ***COMPANY PROFILE***

## ***ABOUT US***

### ***WELCOME TO PENTAX SURGICAL***

*Established in 2008, PENTAX SURGICAL is on a mission to redefine the industry by proving that quality doesn't have to be sacrificed for competitiveness. Our commitment revolves around producing high-quality instruments at prices that keep you smiling. From our humble beginnings as a family-run venture, we've evolved into a significant player in the market.*

*Our mission is clear to instill confidence in our clients by delivering Instruments of the highest quality at prices that make sense. We understand that the key to success lies in customer satisfaction and loyalty, which forms the core of our vision. As we grow, our focus remains on fostering strong relationships with our customers*

*At PENTAX SURGICAL, we firmly believe that quality is never accidental, it's the outcome of thoughtful and intelligent effort. Each instrument we produce reflects this commitment to excellence, ensuring you receive products that exceed expectations. Join us on our journey as we continue to set new standards in quality and customer satisfaction.*

Sterile Skalpelling, Skalpellinggriffe  
Sterile Scalpel Blades, Scalpel Handles  
Hojas de bisturíes estériles, Mangos de bisturíes  
Lame per bisturi sterili, Manici per bisturi



No. 3  
13,0 cm, 5"  
003-003-00

No. 3  
13,0 cm, 5"  
003-003-01

No. 3L  
21,0 cm, 8¼"  
003-003-02

No. 7  
16,5 cm, 6½"  
003-007-00

No. 7K  
13,0 cm, 5"  
003-007-01



No. 4  
13,5 cm, 5<sup>3</sup>/<sub>8</sub>"  
003-004-00



No. 4L  
21,0 cm, 8<sup>3</sup>/<sub>8</sub>"  
003-004-01



No. 8  
13,5 cm, 5<sup>3</sup>/<sub>8</sub>"  
003-008-00



No. 9  
14,5 cm, 5<sup>7</sup>/<sub>8</sub>"  
003-009-00

Einmal-Skalpelle, steril  
Disposable Scalpels, sterile  
Bisturios para uso único, estériles  
Bisturi monouso, sterili



Fig. 10  
003-050-10



Fig. 11  
003-050-11



Fig. 11s  
003-050-11S



Fig. 12  
003-050-12



Fig. 12d  
003-050-12D



Fig. 13  
003-050-13



Fig. 15  
003-050-15



Fig. 15c  
003-050-15C



Fig. 18  
003-050-18



Fig. 19  
003-050-19



Fig. 20  
003-050-20



Fig. 21  
003-050-21



Fig. 22  
003-050-22



Fig. 23  
003-050-23



Fig. 24  
003-050-24



Fig. 1 003-066-01  
Fig. 2 003-066-02  
Fig. 3 003-066-03



**OPERATION**  
17,0 cm, 6¾"

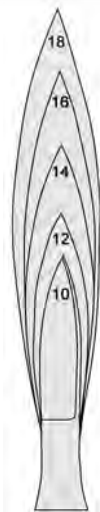

Fig. 10 003-060-10  
Fig. 12 003-060-12  
Fig. 14 003-060-14  
Fig. 16 003-060-16  
Fig. 18 003-060-18



**COLLIN**  
16,0 cm, 6¼"



Fig. 4 003-066-04  
Fig. 5 003-066-05  
Fig. 6 003-066-06



Fig. 1 003-070-01  
Fig. 2 003-070-02  
Fig. 3 003-070-03  
Fig. 4 003-070-04  
Fig. 5 003-070-05



Fig. 1 003-076-01  
Fig. 2 003-076-02  
Fig. 3 003-076-03  
Fig. 4 003-076-04  
Fig. 5 003-076-05



Fig. 15 003-078-15



**DISSECTING**  
17,0 cm, 6¾"



Fig. 6 003-070-06  
Fig. 7 003-070-07  
Fig. 8 003-070-08  
Fig. 9 003-070-09  
Fig. 10 003-070-10



**DIEFENBACH**  
16,0 cm, 6¼"



Fig. 6 003-076-06  
Fig. 7 003-076-07  
Fig. 8 003-076-08  
Fig. 9 003-076-09

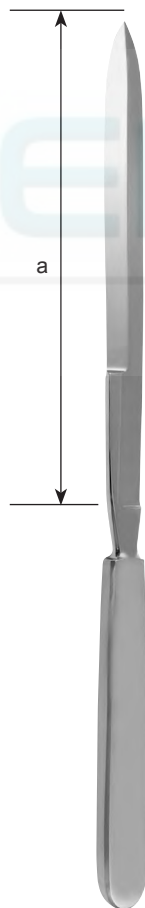

Fig. 16 003-078-16



**COLLIN**

a	
13,0 cm, 5"	<b>003-080-13</b>
16,0 cm, 6 <sup>1</sup> / <sub>4</sub> "	<b>003-080-16</b>
19,0 cm, 7 <sup>1</sup> / <sub>2</sub> "	<b>003-080-19</b>
22,0 cm, 8 <sup>5</sup> / <sub>8</sub> "	<b>003-080-22</b>
28,0 cm, 11"	<b>003-080-28</b>



**CATLIN**

A	
16,0 cm, 6 <sup>1</sup> / <sub>4</sub> "	<b>003-082-16</b>
19,0 cm, 7 <sup>1</sup> / <sub>2</sub> "	<b>003-082-19</b>
22,0 cm, 8 <sup>5</sup> / <sub>8</sub> "	<b>003-082-22</b>

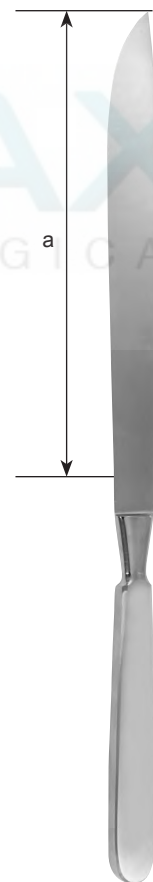

**LISTON**

A	
17,0 cm, 6 <sup>3</sup> / <sub>4</sub> "	<b>003-250-17</b>
20,0 cm, 8"	<b>003-250-20</b>
22,0 cm, 8 <sup>5</sup> / <sub>8</sub> "	<b>003-250-22</b>

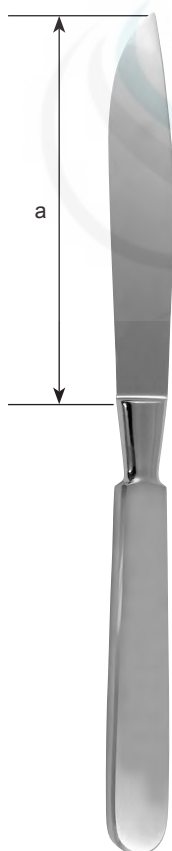

**LANGENBECK**  
003-280-12

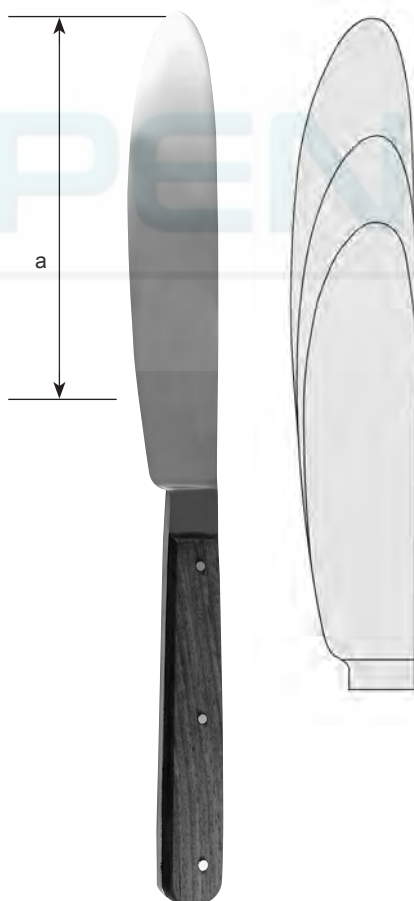

**WALB**

A	
11,0 cm, 4 1/2"	<b>003-150-11</b>
14,0 cm, 5 1/2"	<b>003-150-14</b>
17,0 cm, 6 3/4"	<b>003-150-17</b>

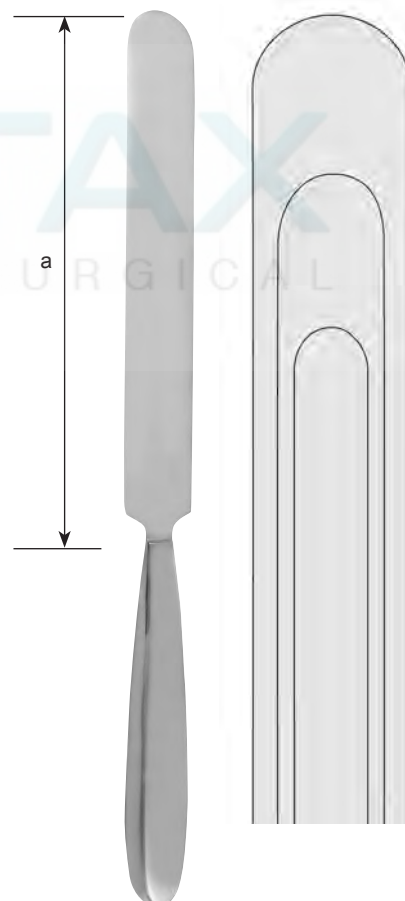

**VIRCHOW**

A	
16,0 cm, 6 1/4"	<b>003-180-16</b>
20,0 cm, 8"	<b>003-180-20</b>
24,0 cm, 9 1/2"	<b>003-180-24</b>

Amputationsmesser, Dermatome  
Amputation Knives, Dermatomes  
Cuchillos para amputación, Dermátomos  
Coltelli per amputazione, Dermatomi



**LANGENBECK**  
18,0 cm, 7"  
003-105-55



**CARTILAGE**  
17,5 cm, 6<sup>5</sup>/<sub>8</sub>"  
003-110-65

mit Schaber  
with raspatory  
con periostótomo  
con raschiatoio



Haut-Spannplatten  
Skin straightening plate  
Placa para extender la piel  
Placca per stendere la pelle

003-422-30

**003-401-19**  
Ersatzklinge  
Spare blade  
Hoja de repuesto  
Lama di ricambio

**003-411-30**  
Ersatzklinge  
Spare blade  
Hoja de repuesto  
Lama di ricambio

**003-413-35**  
Ersatzklinge  
Spare blade  
Hoja de repuesto  
Lama di ricambio

**003-421-30**  
Ersatzklinge  
Spare blade  
Hoja de repuesto  
Lama di ricambio



**SILVER**  
19 cm, 7½"  
003-400-19



**BRAITHWAITE**  
30,0 cm, 12"  
003-410-30



**HUMBY**  
35,0 cm, 14"  
003-412-35



**SCHINK**  
30,0 cm, 12"  
003-420-30

**Scheren**

**Scissors**

**Tijeras**

**Forbici**

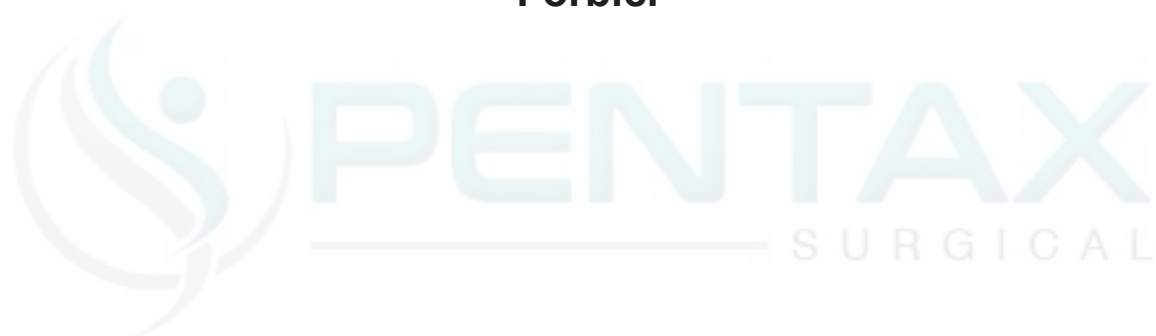



STANDARD	
10,5 cm, 4 <sup>1</sup> / <sub>4</sub> "	010-000-10
11,5 cm, 4 <sup>1</sup> / <sub>2</sub> "	010-000-11
13,0 cm, 5"	010-000-13
14,5 cm, 5 <sup>3</sup> / <sub>4</sub> "	010-000-14
15,5 cm, 6"	010-000-15
16,5 cm, 6 <sup>1</sup> / <sub>2</sub> "	010-000-16
17,5 cm, 6 <sup>5</sup> / <sub>8</sub> "	010-000-17
18,5 cm, 7 <sup>1</sup> / <sub>4</sub> "	010-000-18
20,0 cm, 8"	010-000-20



STANDARD	
10,5 cm, 4 <sup>1</sup> / <sub>4</sub> "	010-001-10
11,5 cm, 4 <sup>1</sup> / <sub>2</sub> "	010-001-11
13,0 cm, 5"	010-001-13
14,5 cm, 5 <sup>3</sup> / <sub>4</sub> "	010-001-14
15,5 cm, 6"	010-001-15
16,5 cm, 6 <sup>1</sup> / <sub>2</sub> "	010-001-16
17,5 cm, 6 <sup>5</sup> / <sub>8</sub> "	010-001-17
18,5 cm, 7 <sup>1</sup> / <sub>4</sub> "	010-001-18
20,0 cm, 8"	010-001-20

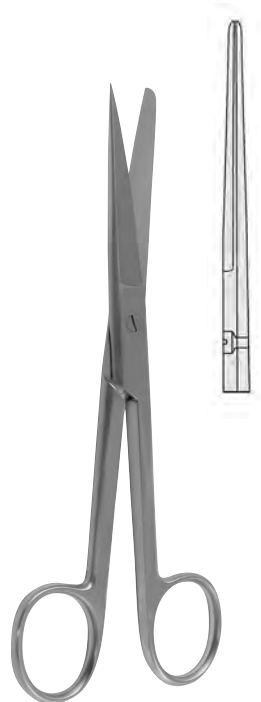

STANDARD	
10,5 cm, 4 <sup>1</sup> / <sub>4</sub> "	010-002-10
11,5 cm, 4 <sup>1</sup> / <sub>2</sub> "	010-002-11
13,0 cm, 5"	010-002-13
14,5 cm, 5 <sup>3</sup> / <sub>4</sub> "	010-002-14
15,5 cm, 6"	010-002-15
16,5 cm, 6 <sup>1</sup> / <sub>2</sub> "	010-002-16
17,5 cm, 6 <sup>5</sup> / <sub>8</sub> "	010-002-17
18,5 cm, 7 <sup>1</sup> / <sub>4</sub> "	010-002-18
20,0 cm, 8"	010-002-20

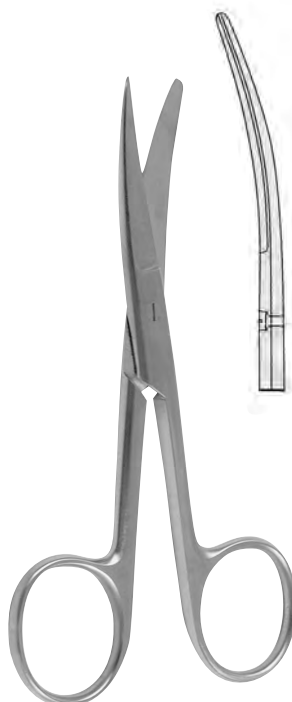

STANDARD	
10,5 cm, 4 <sup>1</sup> / <sub>4</sub> "	010-003-10
11,5 cm, 4 <sup>1</sup> / <sub>2</sub> "	010-003-11
13,0 cm, 5"	010-003-13
14,5 cm, 5 <sup>3</sup> / <sub>4</sub> "	010-003-14
15,5 cm, 6"	010-003-15
16,5 cm, 6 <sup>1</sup> / <sub>2</sub> "	010-003-16
17,5 cm, 6 <sup>5</sup> / <sub>8</sub> "	010-003-17
18,5 cm, 7 <sup>1</sup> / <sub>4</sub> "	010-003-18
20,0 cm, 8"	010-003-20

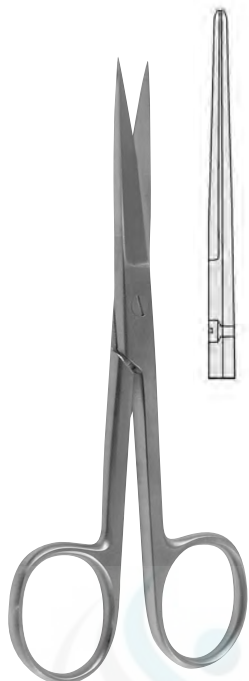

**STANDARD**

10,5 cm, 4 <sup>1</sup> / <sub>4</sub> "	<b>010-004-10</b>
11,5 cm, 4 <sup>1</sup> / <sub>2</sub> "	<b>010-004-11</b>
13,0 cm, 5"	<b>010-004-13</b>
14,5 cm, 5 <sup>3</sup> / <sub>4</sub> "	<b>010-004-14</b>
15,5 cm, 6"	<b>010-004-15</b>
16,5 cm, 6 <sup>1</sup> / <sub>2</sub> "	<b>010-004-16</b>
17,5 cm, 6 <sup>5</sup> / <sub>8</sub> "	<b>010-004-17</b>
18,5 cm, 7 <sup>1</sup> / <sub>4</sub> "	<b>010-004-18</b>
20,0 cm, 8"	<b>010-004-20</b>

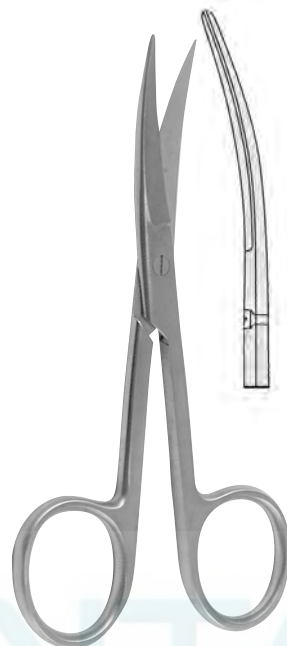

**STANDARD**

10,5 cm, 4 <sup>1</sup> / <sub>4</sub> "	<b>010-005-10</b>
11,5 cm, 4 <sup>1</sup> / <sub>2</sub> "	<b>010-005-11</b>
13,0 cm, 5"	<b>010-005-13</b>
14,5 cm, 5 <sup>3</sup> / <sub>4</sub> "	<b>010-005-14</b>
15,5 cm, 6"	<b>010-005-15</b>
16,5 cm, 6 <sup>1</sup> / <sub>2</sub> "	<b>010-005-16</b>
17,5 cm, 6 <sup>5</sup> / <sub>8</sub> "	<b>010-005-17</b>
18,5 cm, 7 <sup>1</sup> / <sub>4</sub> "	<b>010-005-18</b>
20,0 cm, 8"	<b>010-005-20</b>



**DEAVER**

12,0 cm, 4 <sup>3</sup> / <sub>4</sub> "	<b>010-050-12</b>
13,0 cm, 5"	<b>010-050-13</b>
14,5 cm, 5 <sup>3</sup> / <sub>4</sub> "	<b>010-050-14</b>



**DEAVER**

12,0 cm, 4 <sup>3</sup> / <sub>4</sub> "	<b>010-051-12</b>
13,0 cm, 5"	<b>010-051-13</b>
14,5 cm, 5 <sup>3</sup> / <sub>4</sub> "	<b>010-051-14</b>

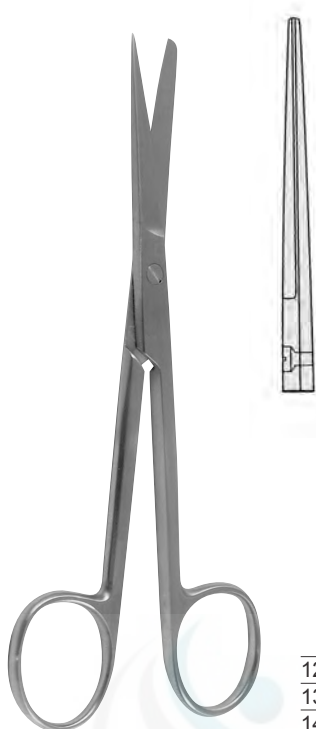

**DEAVER**

12,0 cm, 4 <sup>3</sup> / <sub>4</sub> "	<b>010-052-12</b>
13,0 cm, 5"	<b>010-052-13</b>
14,5 cm, 5 <sup>3</sup> / <sub>4</sub> "	<b>010-052-14</b>

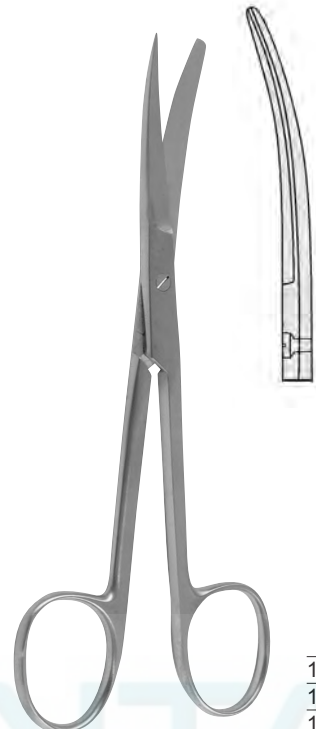

**DEAVER**

12,0 cm, 4 <sup>3</sup> / <sub>4</sub> "	<b>010-053-12</b>
13,0 cm, 5"	<b>010-053-13</b>
14,5 cm, 5 <sup>3</sup> / <sub>4</sub> "	<b>010-053-14</b>

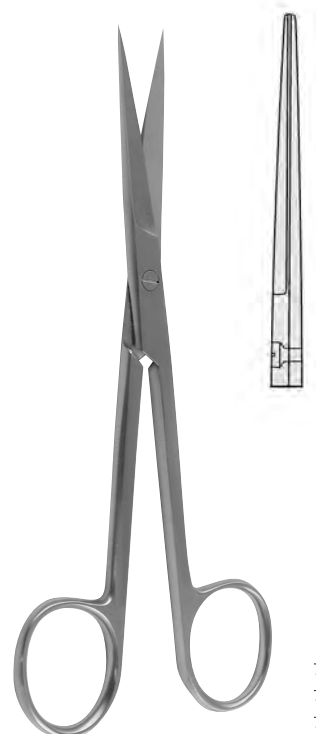

**DEAVER**

12,0 cm, 4 <sup>3</sup> / <sub>4</sub> "	<b>010-054-12</b>
13,0 cm, 5"	<b>010-054-13</b>
14,5 cm, 5 <sup>3</sup> / <sub>4</sub> "	<b>010-054-14</b>

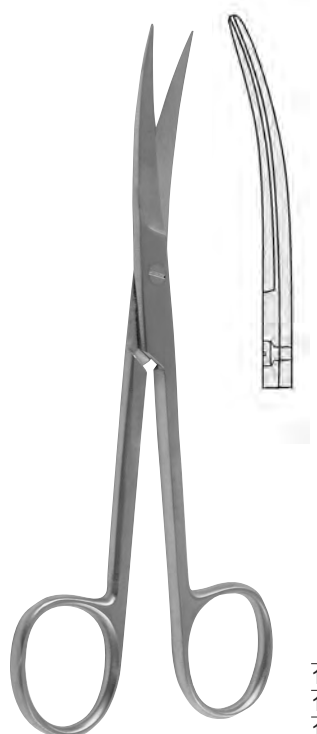

**DEAVER**

12,0 cm, 4 <sup>3</sup> / <sub>4</sub> "	<b>010-055-12</b>
13,0 cm, 5"	<b>010-055-13</b>
14,5 cm, 5 <sup>3</sup> / <sub>4</sub> "	<b>010-055-14</b>

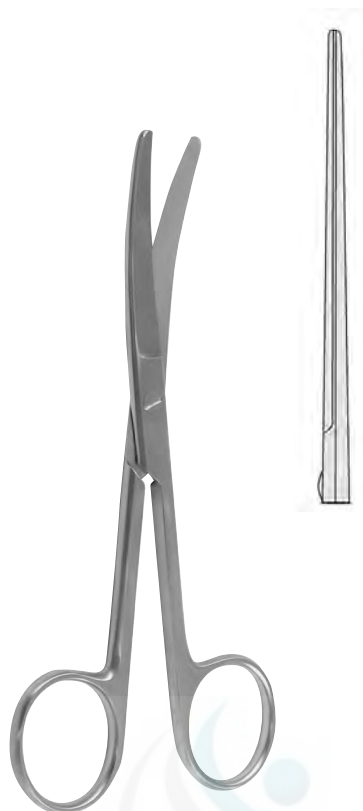

**GRAZIL**  
13,0 cm, 5" **010-070-13**  
14,5 cm, 5<sup>3</sup>/<sub>4</sub>" **010-070-14**

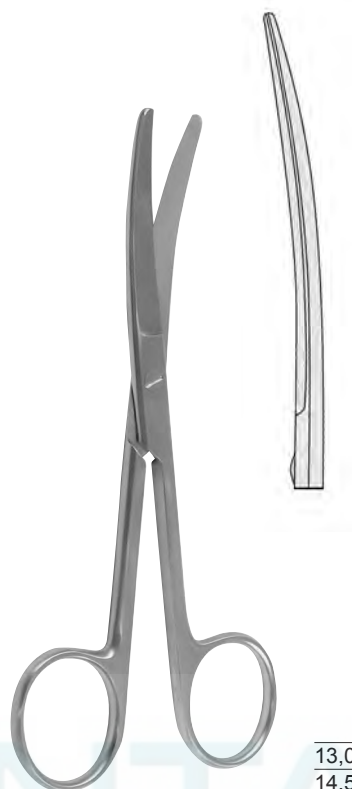

**GRAZIL**  
13,0 cm, 5" **010-071-13**  
14,5 cm, 5<sup>3</sup>/<sub>4</sub>" **010-071-14**

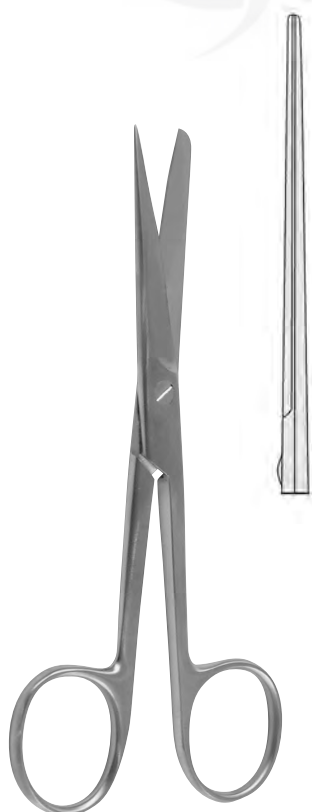

**GRAZIL**  
13,0 cm, 5" **010-072-13**  
14,5 cm, 5<sup>3</sup>/<sub>4</sub>" **010-072-14**

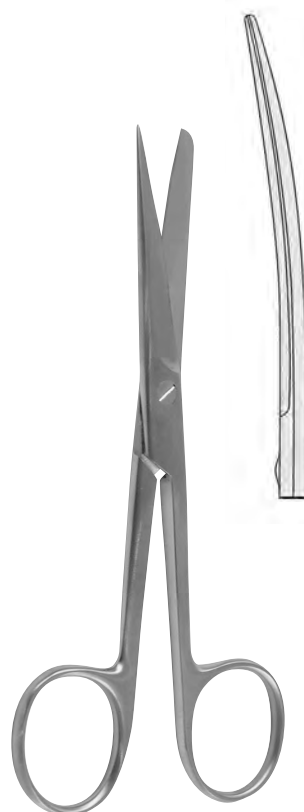

**GRAZIL**  
13,0 cm, 5" **010-073-13**  
14,5 cm, 5<sup>3</sup>/<sub>4</sub>" **010-073-14**



**GRAZIL**  
13,0 cm, 5" **010-074-13**  
14,5 cm, 5<sup>3</sup>/<sub>4</sub>" **010-074-14**

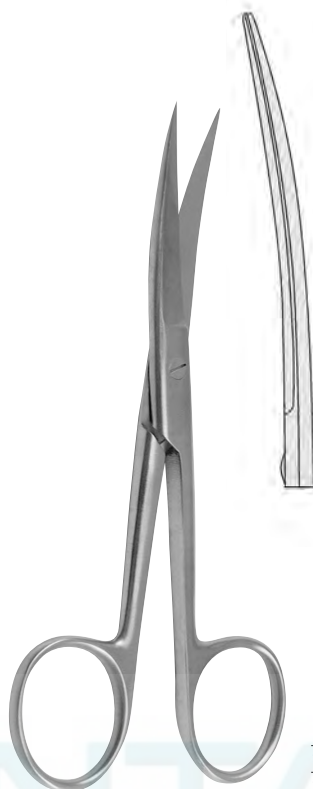

**GRAZIL**  
13,0 cm, 5" **010-075-13**  
14,5 cm, 5<sup>3</sup>/<sub>4</sub>" **010-075-14**

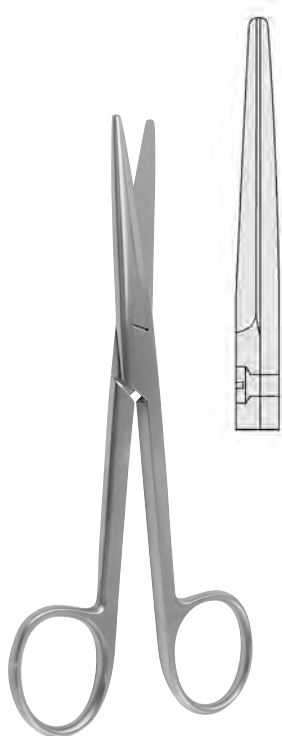

**MAYO**  
14,5 cm, 5<sup>3</sup>/<sub>4</sub>" **010-100-14**  
17,0 cm, 6<sup>3</sup>/<sub>4</sub>" **010-100-17**  
23,0 cm, 9" **010-100-23**  
28,0 cm, 11" **010-100-28**

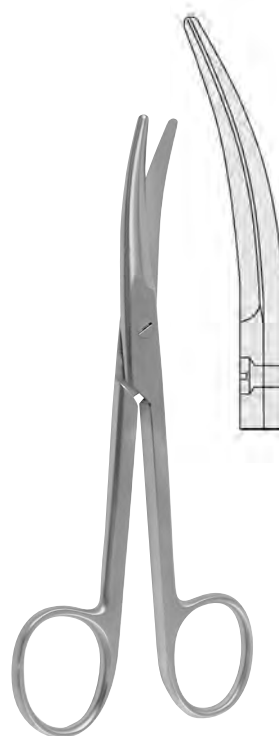

**MAYO**  
14,5 cm, 5<sup>3</sup>/<sub>4</sub>" **010-101-14**  
17,0 cm, 6<sup>3</sup>/<sub>4</sub>" **010-101-17**  
23,0 cm, 9" **010-101-23**  
28,0 cm, 11" **010-101-28**



#### MAYO-STILE

15,0 cm, 6"	010-102-15
17,0 cm, 6 <sup>3</sup> / <sub>4</sub> "	010-102-17
19,5 cm, 7 <sup>3</sup> / <sub>4</sub> "	010-102-19
21,0 cm, 8 <sup>1</sup> / <sub>4</sub> "	010-102-21

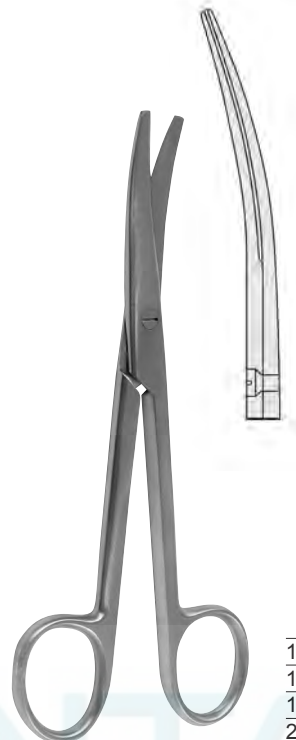

#### MAYO-STILE

15,0 cm, 6"	010-103-15
17,0 cm, 6 <sup>3</sup> / <sub>4</sub> "	010-103-17
19,5 cm, 7 <sup>3</sup> / <sub>4</sub> "	010-103-19
21,0 cm, 8 <sup>1</sup> / <sub>4</sub> "	010-103-21



010-104-17

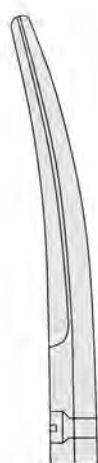

010-105-17

#### MAYO-NOBLE

17,0 cm, 6<sup>3</sup>/<sub>4</sub>"

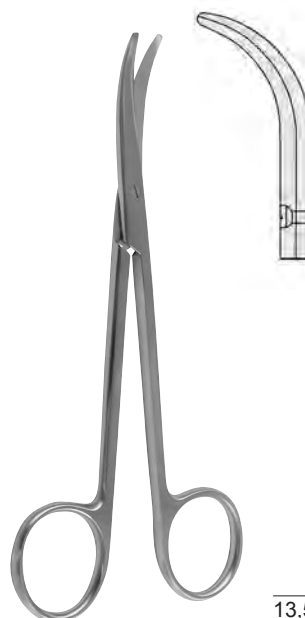

#### FOMON

13,5 cm, 5<sup>3</sup>/<sub>8</sub>" 010-009-13

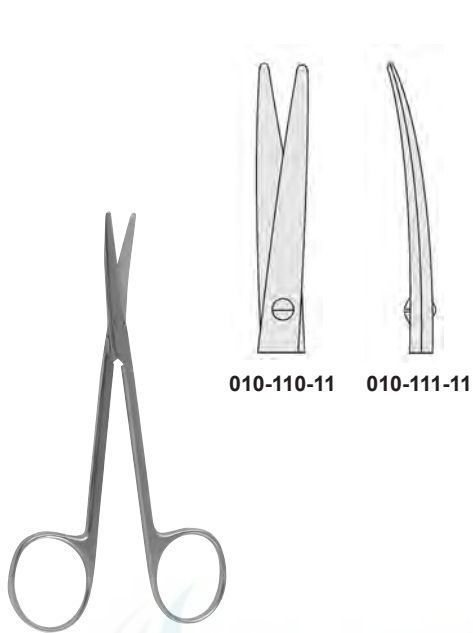

**BABY-METZENBAUM**  
11,5 cm, 4 $\frac{1}{2}$ "



**METZENBAUM**  
14,5 cm, 5 $\frac{3}{4}$ "

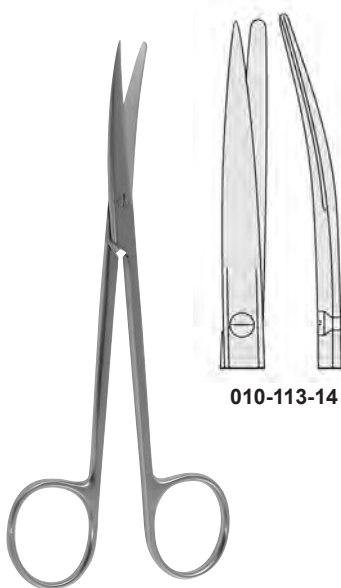

**METZENBAUM**  
14,5 cm, 5 $\frac{3}{4}$ "

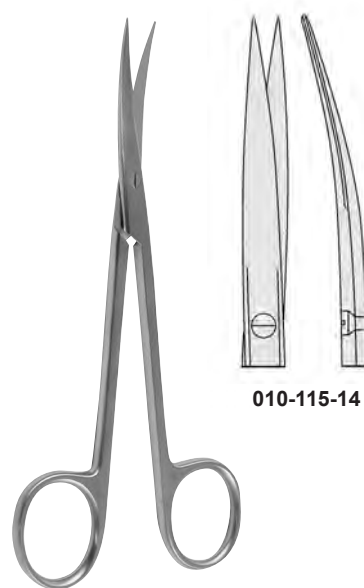

**METZENBAUM**  
14,5 cm, 5 $\frac{3}{4}$ "

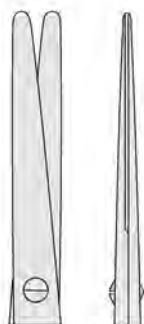

**METZENBAUM**

18,0 cm, 7"	<b>010-110-18</b>
20,0 cm, 8"	<b>010-110-20</b>
23,0 cm, 9"	<b>010-110-23</b>
25,0 cm, 10"	<b>010-110-25</b>
28,0 cm, 11"	<b>010-110-28</b>
30,0 cm, 12"	<b>010-110-30</b>

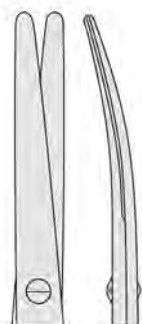
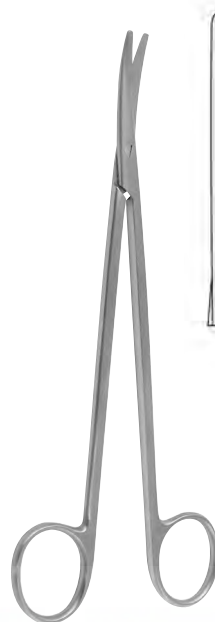

**METZENBAUM**

18,0 cm, 7"	<b>010-111-18</b>
20,0 cm, 8"	<b>010-111-20</b>
23,0 cm, 9"	<b>010-111-23</b>
25,0 cm, 10"	<b>010-111-25</b>
28,0 cm, 11"	<b>010-111-28</b>
30,0 cm, 12"	<b>010-111-30</b>

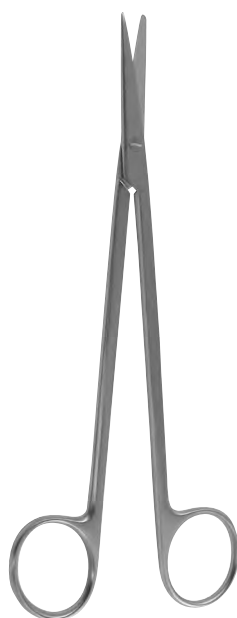

**METZENBAUM**

18,0 cm, 7"	<b>010-112-18</b>
20,0 cm, 8"	<b>010-112-20</b>
23,0 cm, 9"	<b>010-112-23</b>
25,0 cm, 10"	<b>010-112-25</b>
28,0 cm, 11"	<b>010-112-28</b>
30,0 cm, 12"	<b>010-112-30</b>

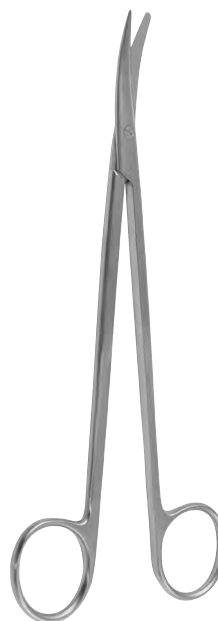

**METZENBAUM**

18,0 cm, 7"	<b>010-113-18</b>
20,0 cm, 8"	<b>010-113-20</b>
23,0 cm, 9"	<b>010-113-23</b>
25,0 cm, 10"	<b>010-113-25</b>
28,0 cm, 11"	<b>010-113-28</b>
30,0 cm, 12"	<b>010-113-30</b>

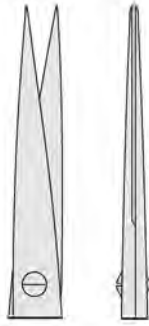

18,0 cm, 7"	<b>010-114-18</b>
20,0 cm, 8"	<b>010-114-20</b>
23,0 cm, 9"	<b>010-114-23</b>
25,0 cm, 10"	<b>010-114-25</b>
28,0 cm, 11"	<b>010-114-28</b>
30,0 cm, 12"	<b>010-114-30</b>

**METZENBAUM**

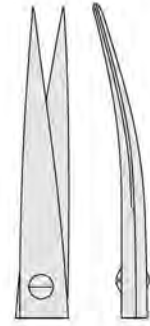
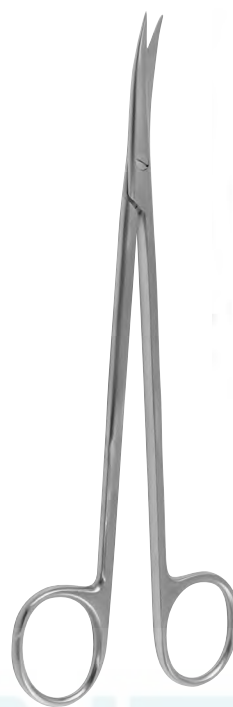

18,0 cm, 7"	<b>010-115-18</b>
20,0 cm, 8"	<b>010-115-20</b>
23,0 cm, 9"	<b>010-115-23</b>
25,0 cm, 10"	<b>010-115-25</b>
28,0 cm, 11"	<b>010-115-28</b>
30,0 cm, 12"	<b>010-115-30</b>

**METZENBAUM**

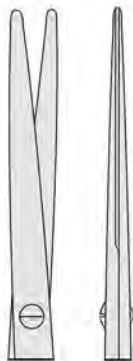

**010-120-14**

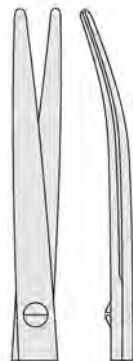

**010-121-14**

**METZENBAUM-FINO**

14,5 cm, 5<sup>3</sup>/<sub>4</sub>"

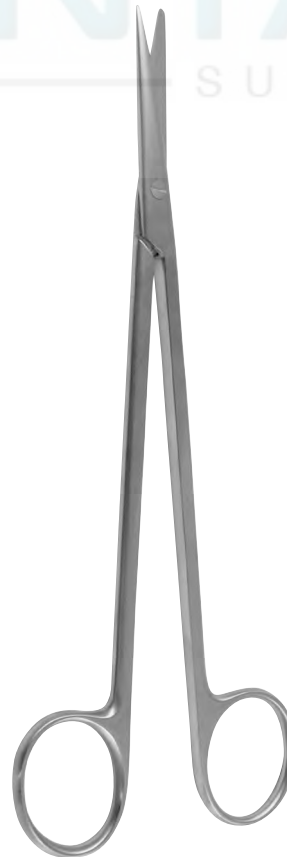

18,0 cm, 7"	<b>010-120-18</b>
20,0 cm, 8"	<b>010-120-20</b>
23,0 cm, 9"	<b>010-120-23</b>
25,0 cm, 10"	<b>010-120-25</b>
28,0 cm, 11"	<b>010-120-28</b>
30,0 cm, 12"	<b>010-120-30</b>

**METZENBAUM-FINO**

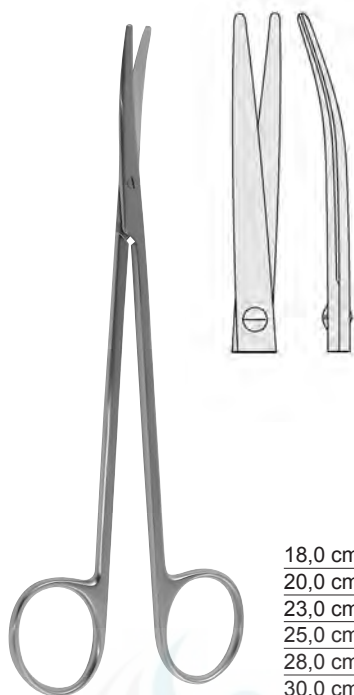

**METZENBAUM-FINO**

18,0 cm, 7"	<b>010-121-18</b>
20,0 cm, 8"	<b>010-121-20</b>
23,0 cm, 9"	<b>010-121-23</b>
25,0 cm, 10"	<b>010-121-25</b>
28,0 cm, 11"	<b>010-121-28</b>
30,0 cm, 12"	<b>010-121-30</b>

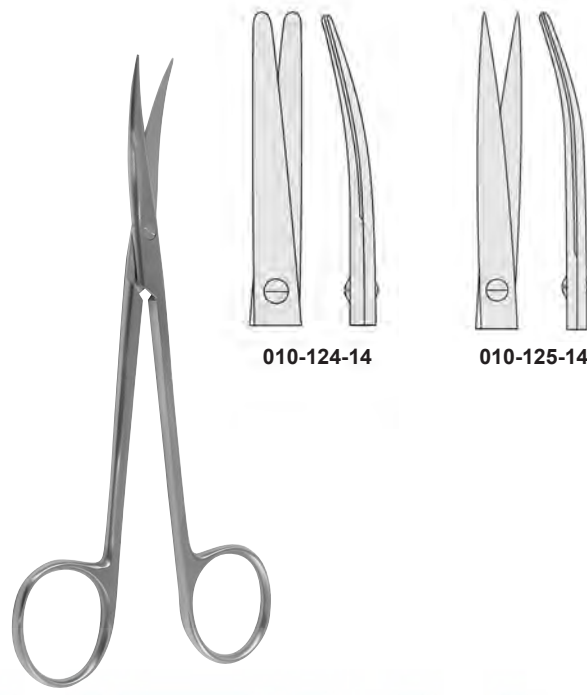

**METZENBAUM-FINO**

14,5 cm, 5<sup>3</sup>/<sub>4</sub>"

**010-124-14**

**010-125-14**

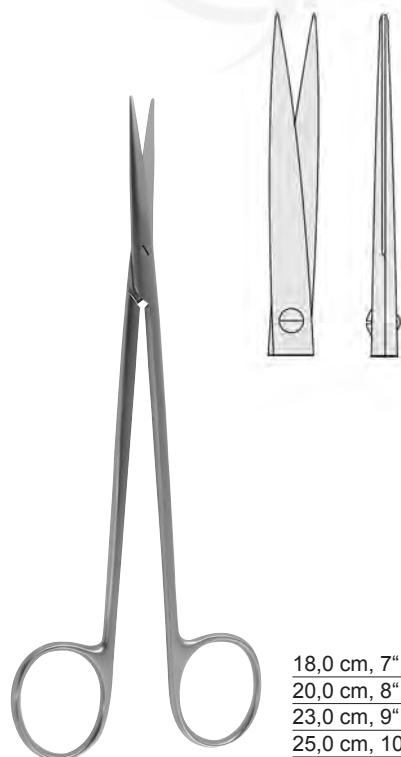

**METZENBAUM-FINO**

18,0 cm, 7"	<b>010-124-18</b>
20,0 cm, 8"	<b>010-124-20</b>
23,0 cm, 9"	<b>010-124-23</b>
25,0 cm, 10"	<b>010-124-25</b>
28,0 cm, 11"	<b>010-124-28</b>
30,0 cm, 12"	<b>010-124-30</b>

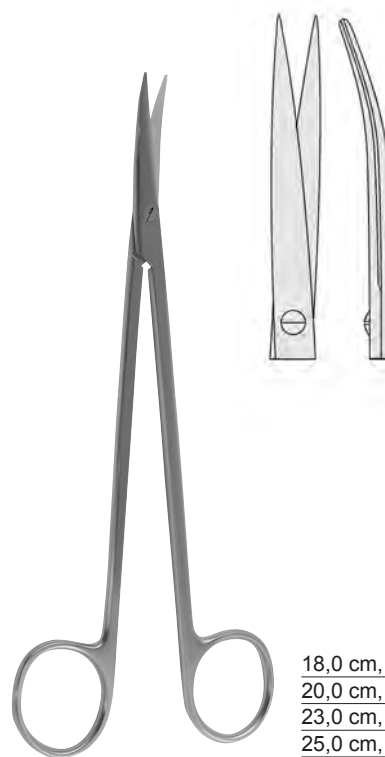

**METZENBAUM-FINO**

18,0 cm, 7"	<b>010-125-18</b>
20,0 cm, 8"	<b>010-125-20</b>
23,0 cm, 9"	<b>010-125-23</b>
25,0 cm, 10"	<b>010-125-25</b>
28,0 cm, 11"	<b>010-125-28</b>
30,0 cm, 12"	<b>010-125-30</b>

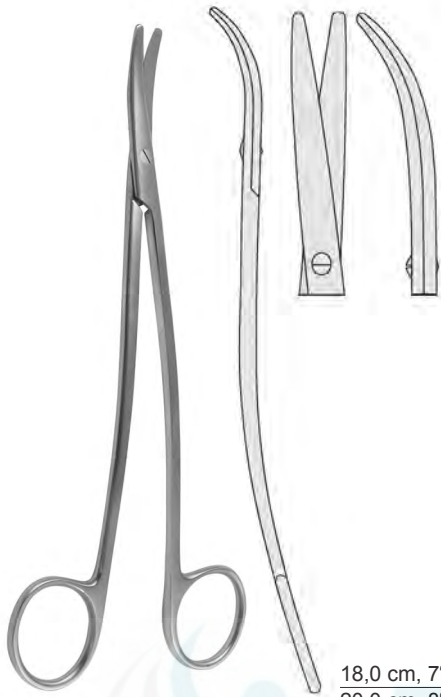

**METZENBAUM-FINO S**

18,0 cm, 7"	<b>010-127-18</b>
20,0 cm, 8"	<b>010-127-20</b>
23,0 cm, 9"	<b>010-127-23</b>

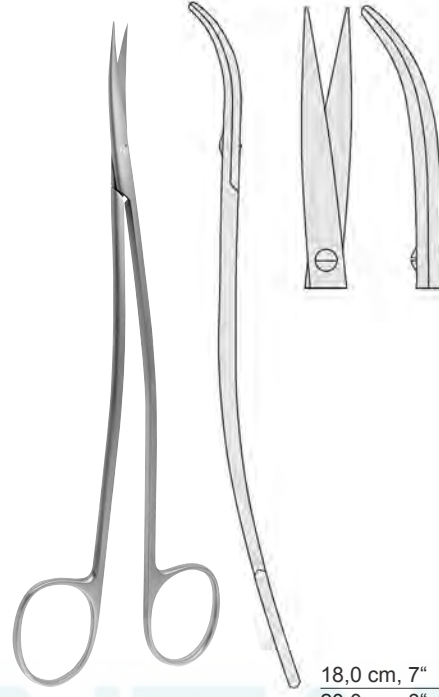

**METZENBAUM-FINO S**

18,0 cm, 7"	<b>010-129-18</b>
20,0 cm, 8"	<b>010-129-20</b>
23,0 cm, 9"	<b>010-129-23</b>



**METZENBAUM-LAHEY**

14,0 cm, 5 1/2"    **010-137-14**

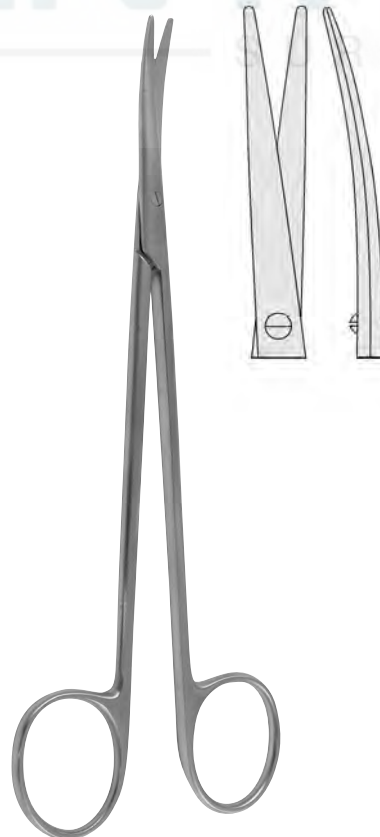

**TOENNIS-ADSON**

17,0 cm, 6 3/4"    **010-139-17**

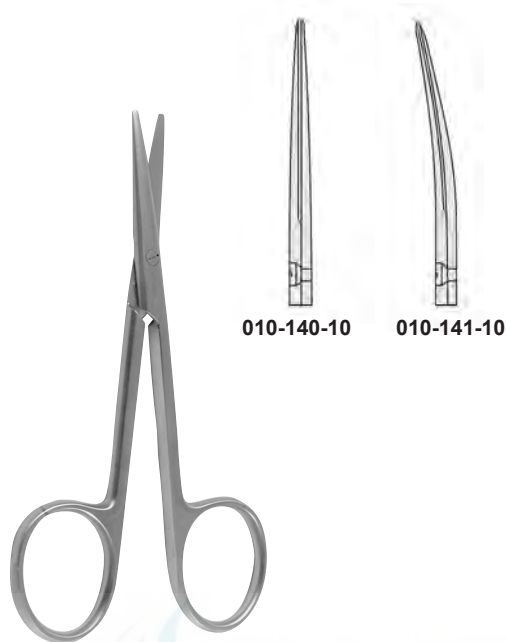

010-140-10

010-141-10

**BABY-LEXER**  
10,0 cm, 4"

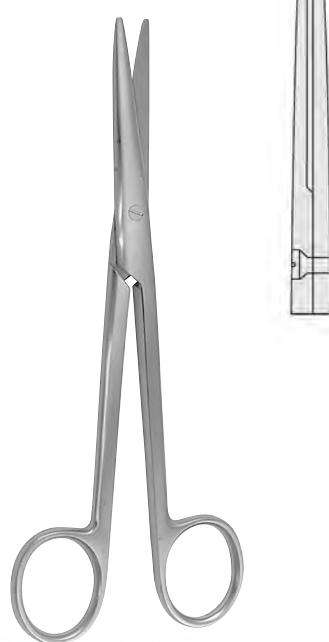

16,0 cm, 6<sup>1</sup>/<sub>4</sub>"  
21,0 cm, 8<sup>1</sup>/<sub>4</sub>"

**010-140-16**  
**010-140-21**

**LEXER**

PENTAX  
SURGICAL

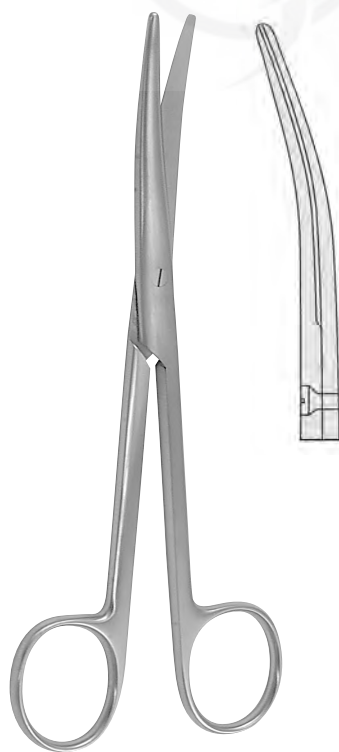

16,0 cm, 6<sup>1</sup>/<sub>4</sub>"  
21,0 cm, 8<sup>1</sup>/<sub>4</sub>"

**010-141-16**  
**010-141-21**

**LEXER**

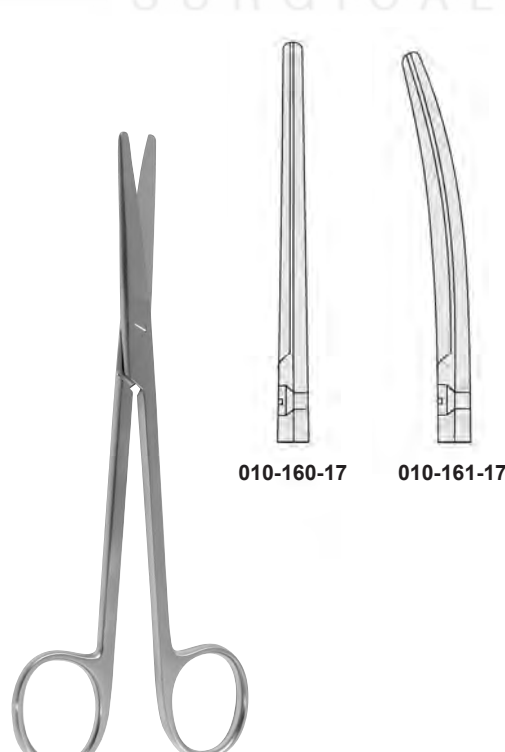

010-160-17

010-161-17

**MIXTER**  
17,0 cm, 6<sup>3</sup>/<sub>4</sub>"

Präparierscheren, feine chirurgische Scheren  
 Dissecting Scissors, fine surgical scissors  
 Tijeras de disección, tijeras finas para cirugía  
 Forbici per dissezione, forbici fine per chirurgia



12,0 cm, 4 <sup>3</sup> / <sub>4</sub> "	<b>010-200-12</b>
15,0 cm, 6"	<b>010-200-15</b>
18,0 cm, 7"	<b>010-200-18</b>
20,0 cm, 8"	<b>010-200-20</b>

**KILNER (RAGNELL)**



12,0 cm, 4 <sup>3</sup> / <sub>4</sub> "	<b>010-201-12</b>
15,0 cm, 6"	<b>010-201-15</b>
18,0 cm, 7"	<b>010-201-18</b>
20,0 cm, 8"	<b>010-201-20</b>

**KILNER (RAGNELL)**



15,0 cm, 6"	<b>010-210-15</b>
18,0 cm, 7"	<b>010-210-18</b>

**REYNOLDS**

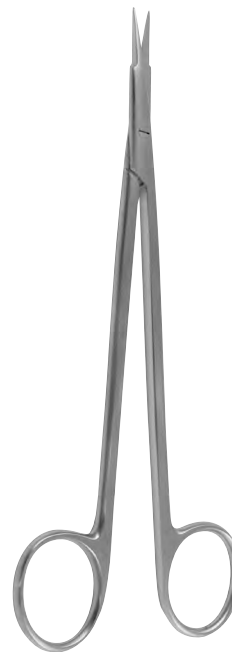

15,0 cm, 6"	<b>010-211-15</b>
18,0 cm, 7"	<b>010-211-18</b>
20,0 cm, 8"	<b>010-211-20</b>
23,0 cm, 9"	<b>010-211-23</b>
25,0 cm, 10"	<b>010-211-25</b>

**REYNOLDS**

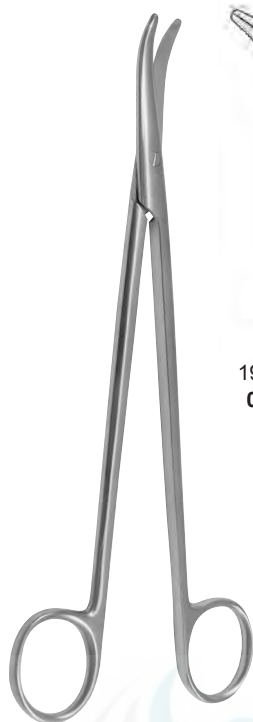

**THOREK**

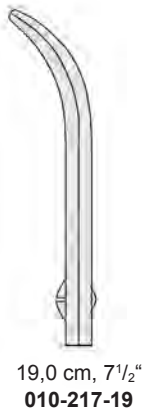

19,0 cm, 7 1/2"  
 010-217-19



25,0 cm, 10"  
 010-217-25



15,0 cm, 6"



010-220-15



010-221-15

Nerv-Präparierschere  
 Nerve dissecting scissors  
 Tijeras para nervios  
 Forbici per dissezione di nervi



**SANVENERO**  
 14,0 cm, 5 1/2"

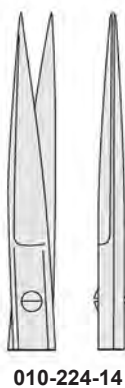

010-224-14

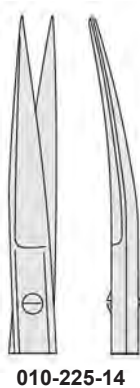

010-225-14



**JOSEPH**  
 14,0 cm, 5 1/2"

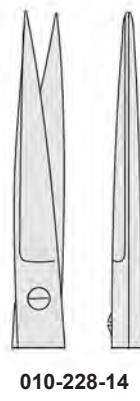

010-228-14

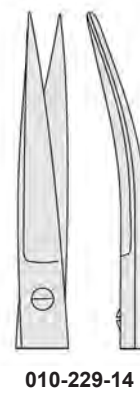

010-229-14

Feine chirurgische Scheren  
 Fine surgical scissors  
 Tijeras finas para cirugía  
 Forbici fine per chirurgia



**WAGNER**  
 12,0 cm, 4<sup>3</sup>/<sub>4</sub>"

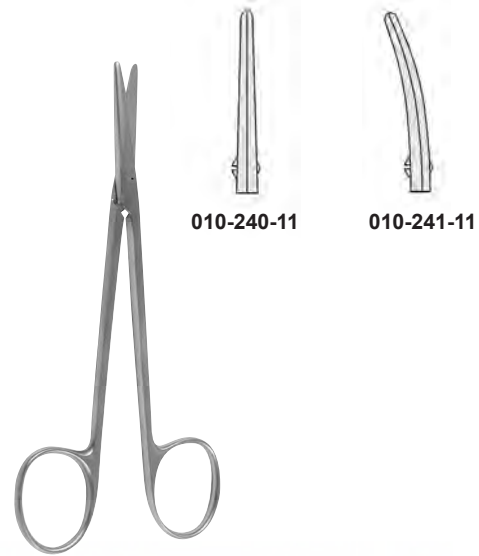

**STRABISMUS**  
 11,5 cm, 4<sup>1</sup>/<sub>2</sub>"

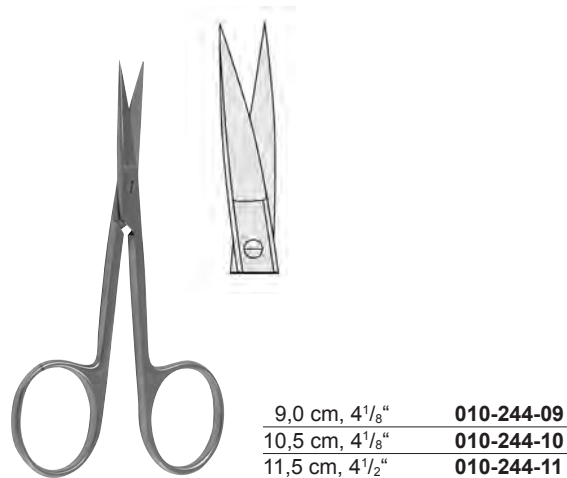

**IRIS**

9,0 cm, 4 <sup>1</sup> / <sub>8</sub> "	<b>010-244-09</b>
10,5 cm, 4 <sup>1</sup> / <sub>8</sub> "	<b>010-244-10</b>
11,5 cm, 4 <sup>1</sup> / <sub>2</sub> "	<b>010-244-11</b>

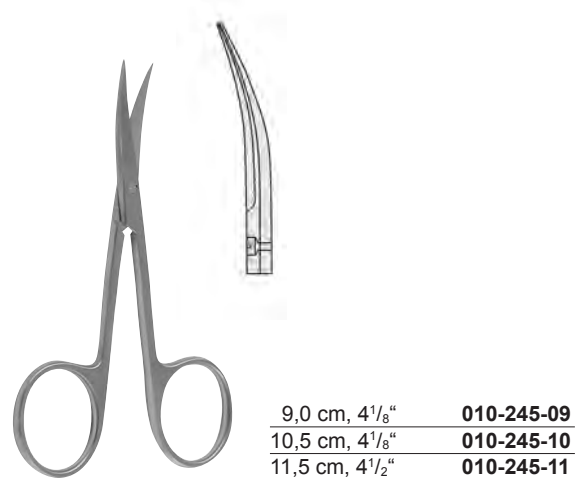

**IRIS**

9,0 cm, 4 <sup>1</sup> / <sub>8</sub> "	<b>010-245-09</b>
10,5 cm, 4 <sup>1</sup> / <sub>8</sub> "	<b>010-245-10</b>
11,5 cm, 4 <sup>1</sup> / <sub>2</sub> "	<b>010-245-11</b>

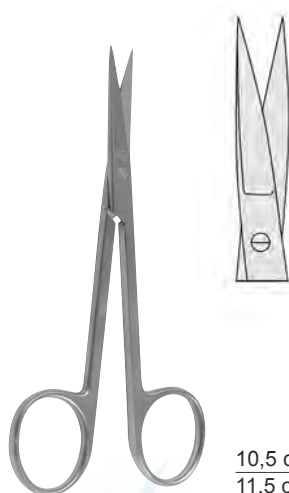

10,5 cm, 4<sup>1</sup>/<sub>8</sub>"     **010-250-10**  
11,5 cm, 4<sup>1</sup>/<sub>2</sub>"     **010-250-11**

IRIS



10,5 cm, 4<sup>1</sup>/<sub>8</sub>"     **010-251-10**  
11,5 cm, 4<sup>1</sup>/<sub>2</sub>"     **010-251-11**

IRIS



11,5 cm, 4<sup>1</sup>/<sub>2</sub>"  
**010-261-11**



11,5 cm, 4<sup>1</sup>/<sub>2</sub>"  
**010-263-11**

Feine chirurgische Scheren  
Fine surgical scissors  
Tijeras finas para cirugía  
Forbici fine per chirurgia

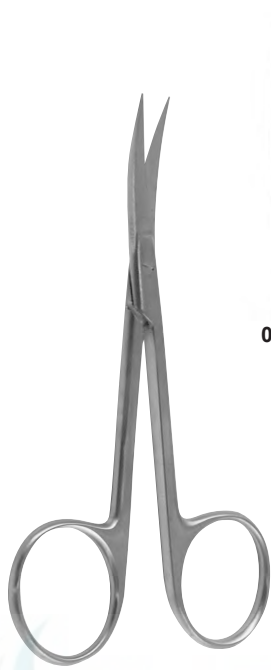

12,0 cm, 4<sup>3</sup>/<sub>4</sub>"



010-264-12



010-265-12



MOD. BONN  
8,0 cm, 3<sup>1</sup>/<sub>4</sub>"  
010-270-08



MOD. BONN  
8,0 cm, 3<sup>1</sup>/<sub>4</sub>"  
010-271-08



MOD. BONN  
8,0 cm, 3<sup>1</sup>/<sub>4</sub>"  
010-273-08

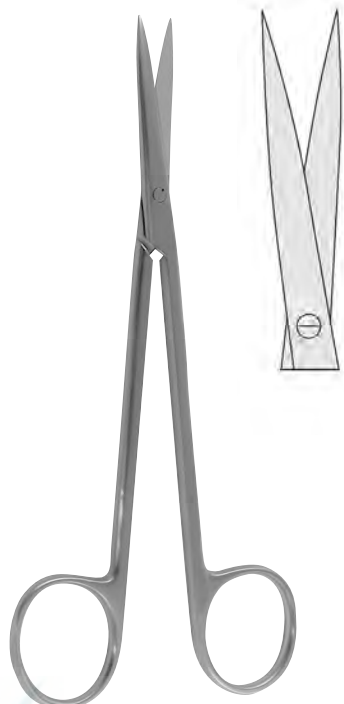

**BROPHY (SULLIVAN)**  
 14,0 cm, 5½"  
 010-276-14



**BROPHY (SULLIVAN)**  
 14,0 cm, 5½"  
 010-277-14

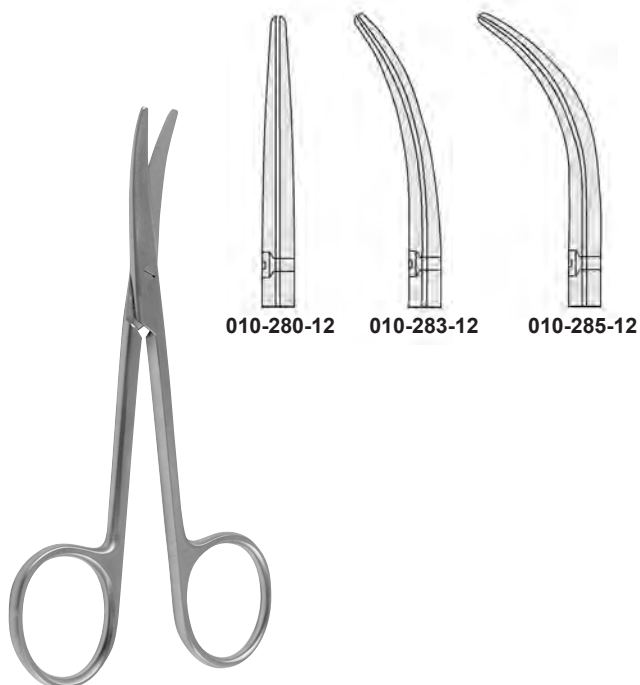

**LANDOLT**  
 12,5 cm, 5"

010-280-12    010-283-12    010-285-12

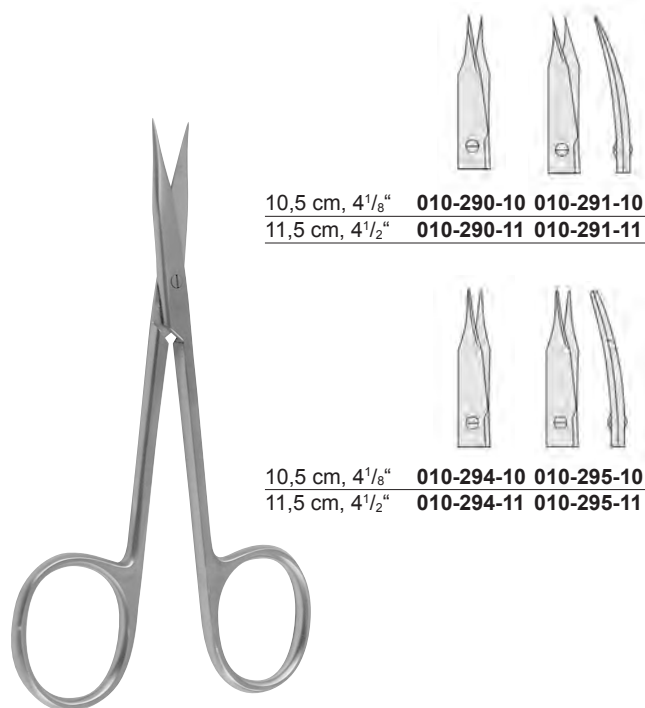

**STEVENS**

10,5 cm, 4¼"    010-290-10    010-291-10  
 11,5 cm, 4½"    010-290-11    010-291-11

10,5 cm, 4¼"    010-294-10    010-295-10  
 11,5 cm, 4½"    010-294-11    010-295-11

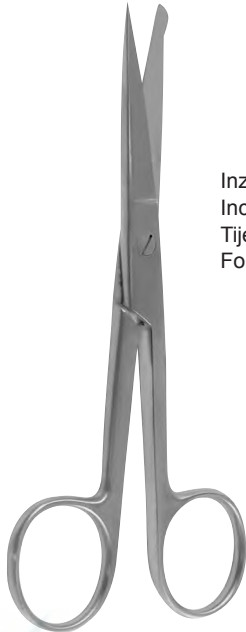

Inzisionsscheren  
Incision scissors  
Tijeras para incisión  
Forbici vascolare e per fistole

13,0 cm, 5"  
14,5 cm, 5<sup>3</sup>/<sub>4</sub>"

**010-300-13**  
**010-300-14**



**RICHTER**  
14,5 cm, 5<sup>3</sup>/<sub>4</sub>"  
**010-310-14**



**FERGUSON**  
16,5 cm, 6<sup>1</sup>/<sub>4</sub>" **010-315-16**  
18,0 cm, 7" **010-315-18**

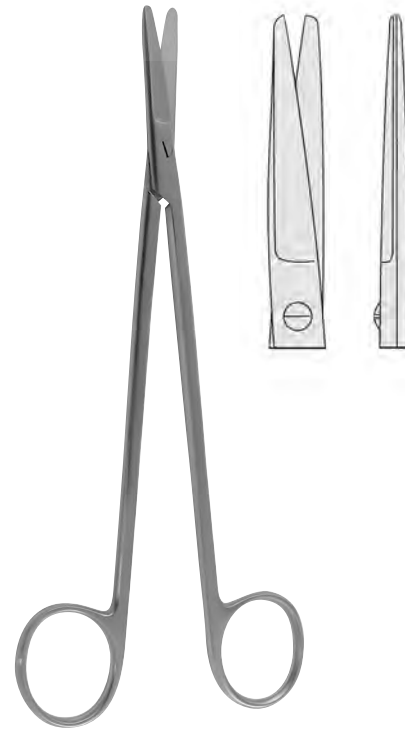

**TOENNIS**  
18,0 cm, 7"  
**010-324-18**

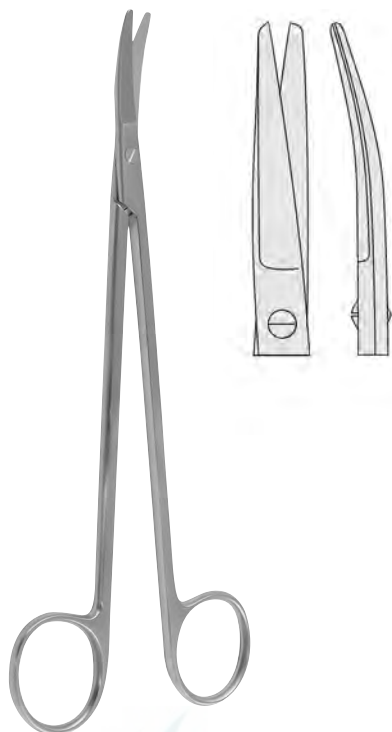

**TOENNIS**  
 18,0 cm, 7"  
 010-325-18

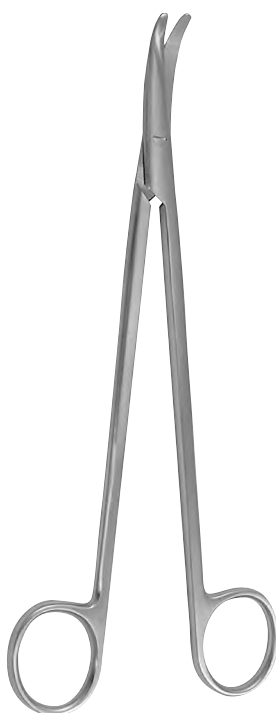

**HALLE**  
 19,0 cm, 7 1/2"  
 010-341-19

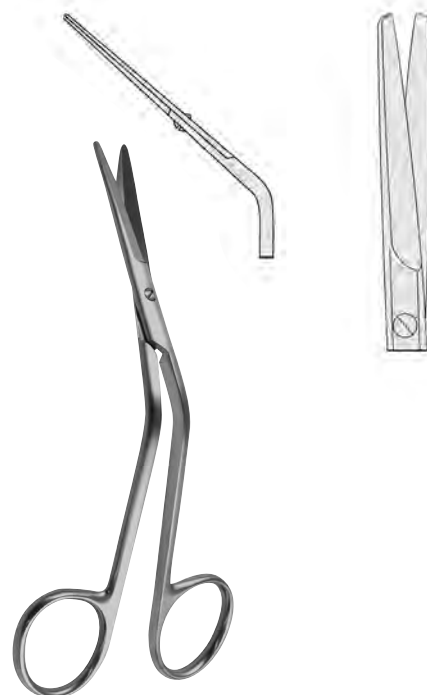

**FOMON**  
 15,0 cm, 6"  
 010-343-15



**SPENCER**  
 9,0 cm, 4 1/8"    **010-400-09**  
 10,5 cm, 4 1/8"    **010-400-10**  
 13,0 cm, 5"    **010-400-13**



**LITTAUER**  
 11,5 cm, 4 1/4"    **010-402-11**  
 14,0 cm, 5 1/2"    **010-402-14**

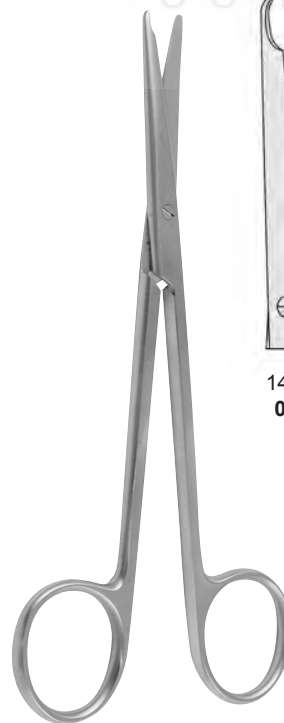

**BUCK**

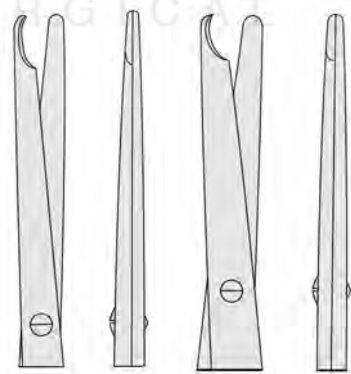

14,5 cm, 5 3/4"  
 010-404-14

18,0 cm, 7"  
 010-404-18

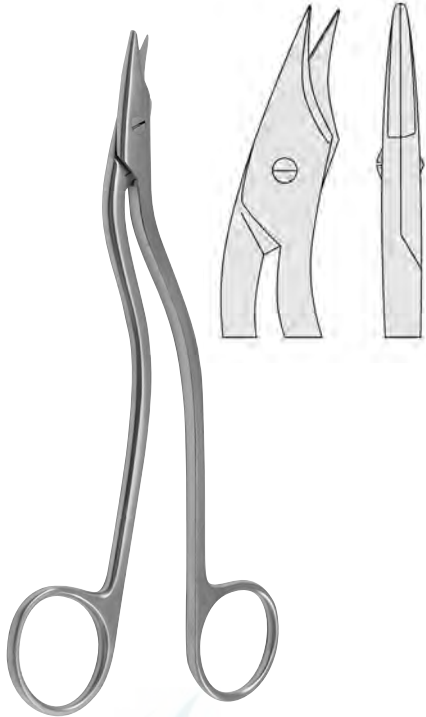

**HEATH**  
 16,0 cm, 6<sup>1</sup>/<sub>4</sub>"  
 010-408-16



**NORTHBENT**  
 9,0 cm, 3<sup>1</sup>/<sub>2</sub>"  
 010-411-19



**NORTHBENT**  
 13,0 cm, 5"  
 010-413-13



**EISELSBERG**  
 12,0 cm, 4<sup>3</sup>/<sub>4</sub>"  
 010-415-12

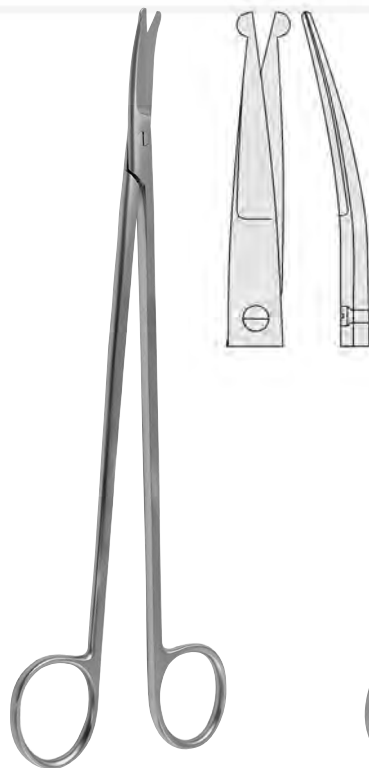

**STRULLY**  
 22,0 cm, 8<sup>5</sup>/<sub>8</sub>"  
 010-450-22

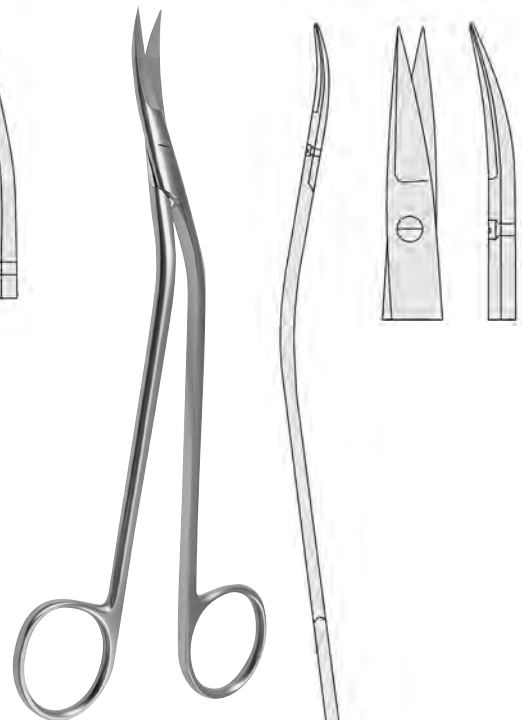

**DANDY**  
 17,0 cm, 6<sup>3</sup>/<sub>4</sub>"  
 010-453-17



**SCHMIEDEN-TAYLOR**  
17,0 cm, 6<sup>3</sup>/<sub>4</sub>"  
010-457-17



**LINCOLN**  
17,0 cm, 6<sup>3</sup>/<sub>4</sub>"

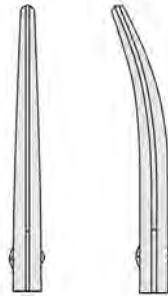

010-458-17 010-459-17



**HEYMANN**  
18,0 cm, 7"  
010-501-18



**COTTLE**  
16,0 cm, 6<sup>1</sup>/<sub>4</sub>"  
010-511-16



**KIRSTEN**  
18,0 cm, 7"  
010-517-18



**CAPLAN**  
22,0 cm, 8<sup>5</sup>/<sub>8</sub>"  
010-519-22

Tonsillenscheren, Nasenscheren, Gefäßscheren  
 Tonsil Scissors, Nasal Scissors, Vascular Scissors  
 Tijeras para amígdalas, Tijeras para el tabique nasal, Tijeras vas  
 Forbici per tonsille, Forbici per il setto nasale, Forbici vascolari

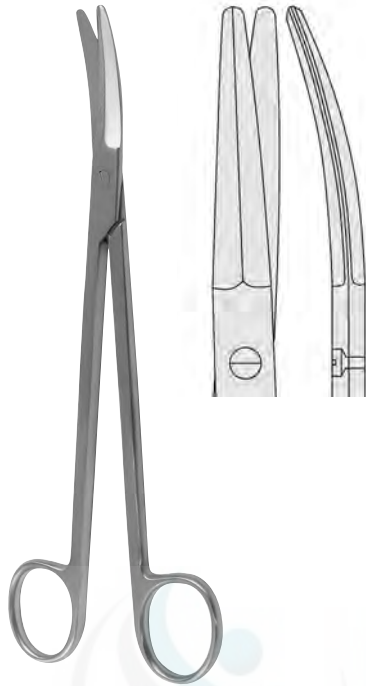

**BOETTCHER**  
 18,0 cm, 7"  
 010-521-18

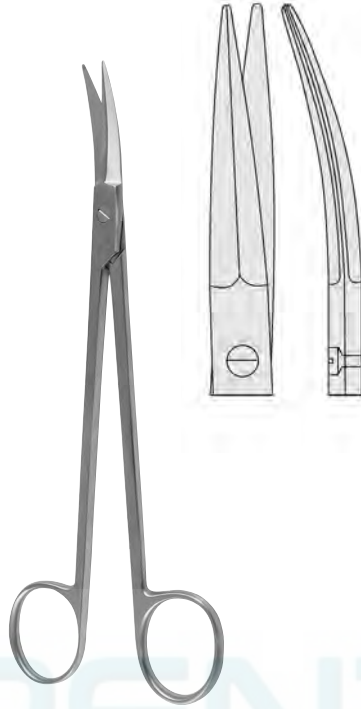

**PRINCE**  
 17,5 cm, 6<sup>5</sup>/<sub>8</sub>"  
 010-523-17

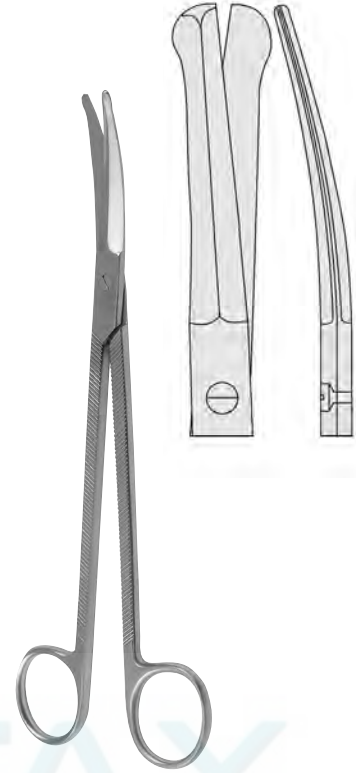

**GOOD**  
 19,0 cm, 7<sup>1</sup>/<sub>2</sub>"  
 010-525-19



**CARTILAGE**  
 20,0 cm, 8"  
 010-528-20

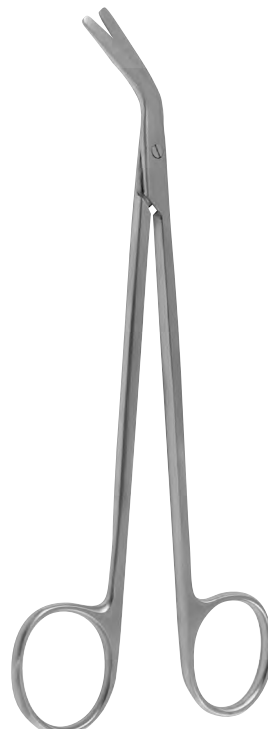

**DE BAKEY**

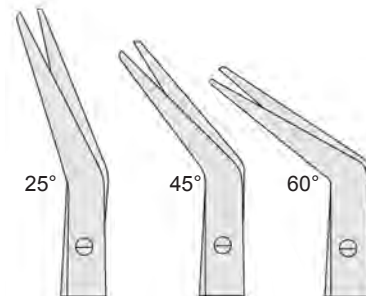

17,5 cm, 6 <sup>5</sup> / <sub>8</sub> "	010-540-25	010-540-45	010-540-60
19,5 cm, 7 <sup>3</sup> / <sub>4</sub> "	010-541-25	010-541-45	010-541-60
21,0 cm, 8 <sup>1</sup> / <sub>4</sub> "	010-542-25	010-542-45	010-542-60
23,0 cm, 9"	010-543-25	010-543-45	010-543-60
28,0 cm, 11"	010-544-25	010-544-45	010-544-60

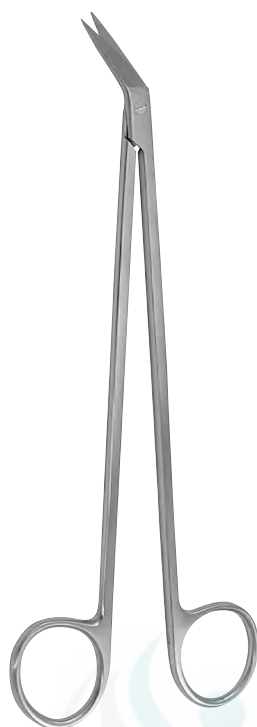

**POTTS-SMITH**  
18,0 cm, 7"  
010-547-18

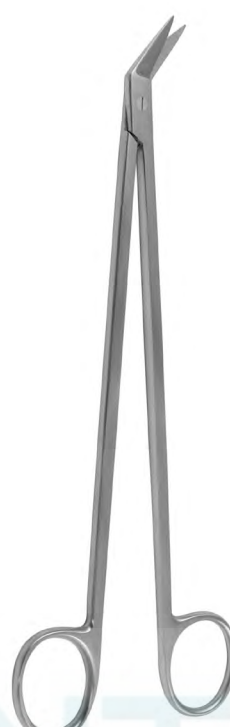
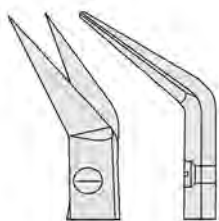

**POTTS DE MARTEL**  
21,0 cm, 8 1/4"    010-548-21  
24,0 cm, 9 1/2"    010-548-24

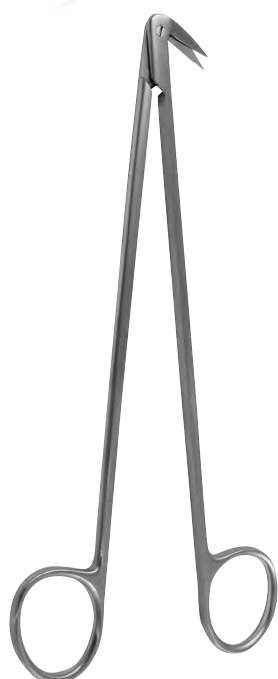
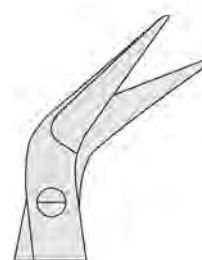

**DIETRICH-HEGEMANN**  
19,0 cm, 7 1/2"

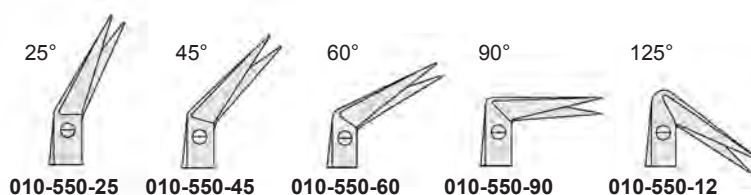



**DIETHRICH**  
 20,0 cm, 7 1/2"  
 010-552-12

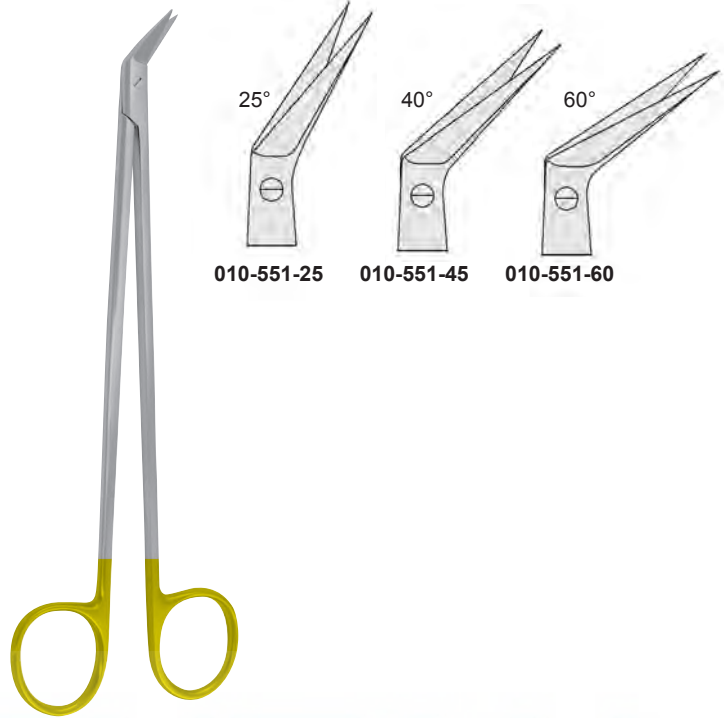

**POTTS-SMITH**  
 19,0 cm, 7 1/2"

25° 010-551-25  
 40° 010-551-45  
 60° 010-551-60



**DE BAKEY**  
 15,5 cm, 6"  
 010-560-15

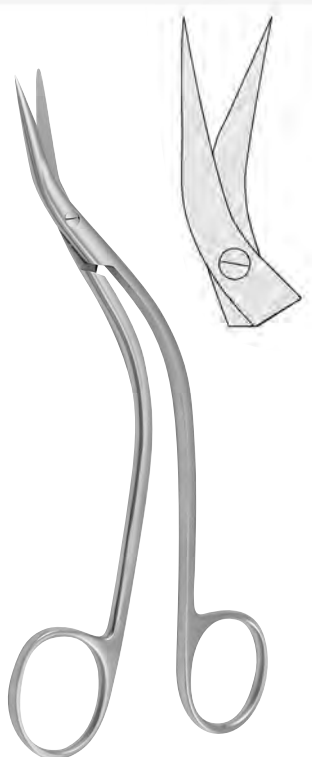

**DE BAKEY**  
 15,5 cm, 6"  
 010-561-15

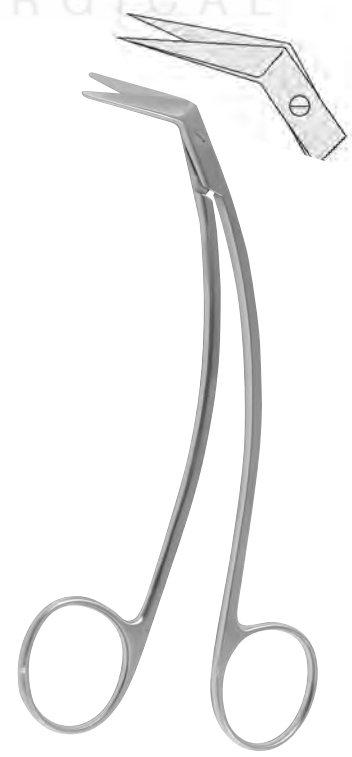

**DE BAKEY**  
 15,5 cm, 6"  
 010-562-15

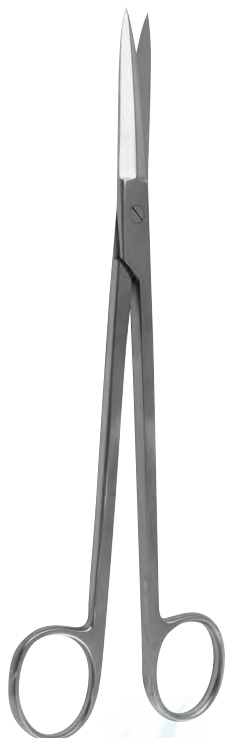

**MC INDOE**  
19,0 cm, 7½"  
010-570-19

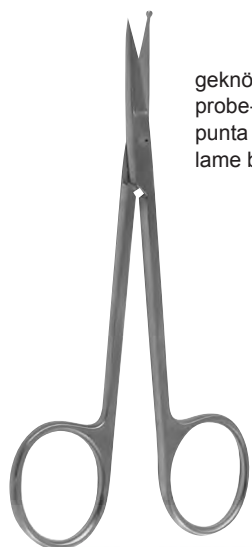

geknöpftes Blatt  
probe-pointed blade  
punta botonda  
lame bottonuta

11,5 cm, 4½"  
010-572-11

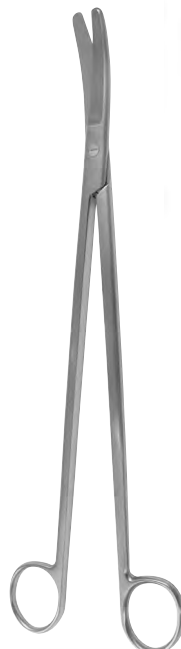

**CRAFOORD**  
30,0 cm, 12"  
010-575-30



**SATINSKY**  
15,5 cm, 9⅝"  
010-577-24



**KLINGENBERG-LOTH**  
23,0 cm, 9"  
010-579-23



**SIMS**



20,0 cm, 8"  
23,0 cm, 9"

010-600-20  
010-600-23



010-602-20  
010-602-23



010-604-20  
010-604-23

Gynäkologische Scheren  
 Gynecology scissors  
 Tijeras para ginecología  
 Forbici per ginecologia

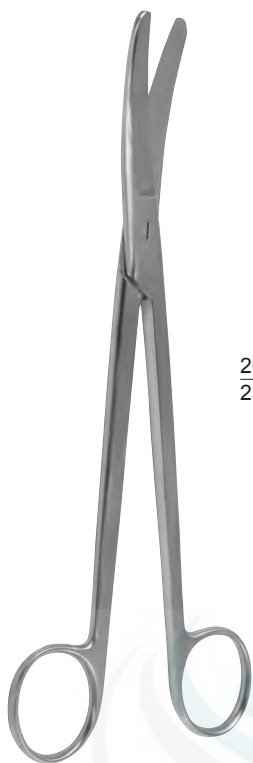

**SIMS**

20,0 cm, 8"	<b>010-601-20</b>	<b>010-603-20</b>	<b>010-605-20</b>
23,0 cm, 9"	<b>010-601-23</b>	<b>010-603-23</b>	<b>010-605-23</b>

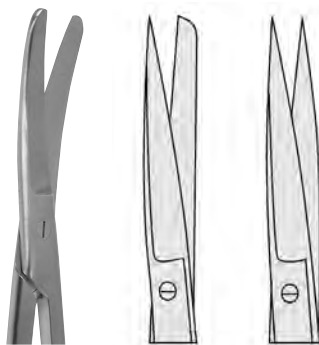

**SIEBOLD**  
 24,0 cm, 9 1/2"  
**010-620-24**



**BOZEMANN**  
 22,0 cm, 8 3/4"  
**010-622-22**



**DOYEN**

16,0 cm, 6 1/4"	<b>010-610-16</b>	<b>010-611-16</b>	<b>010-612-16</b>
17,5 cm, 6 7/8"	<b>010-610-17</b>	<b>010-611-17</b>	

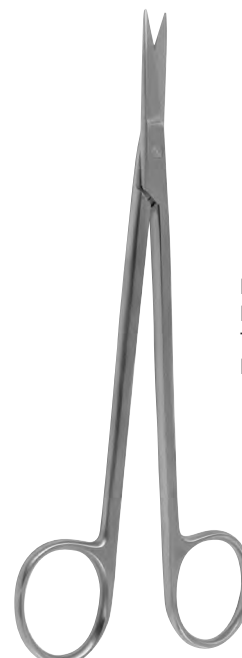
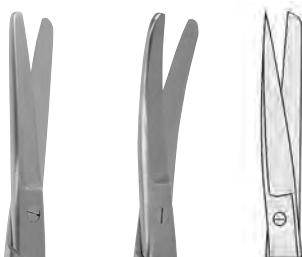

**KELLY**  
 16,0 cm, 6 1/4"     **010-634-16**  
 18,0 cm, 7"         **010-634-18**

Fistelscheren  
 Fistula scissors  
 Tijeras para fistulas  
 Forbici per fistole

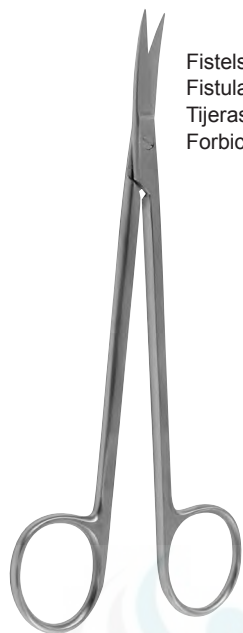

Fistelscheren  
 Fistula scissors  
 Tijeras para fistulas  
 Forbici per fistole

**KELLY**

16,0 cm, 6 <sup>1</sup> / <sub>4</sub> "	<b>010-635-16</b>
18,0 cm, 7"	<b>010-635-18</b>



**WERTHEIM**

19,5 cm, 7 <sup>3</sup> / <sub>4</sub> "	<b>010-640-19</b>
22,5 cm, 8 <sup>3</sup> / <sub>4</sub> "	<b>010-640-23</b>



**DUBOIS**

27,0 cm, 10 <sup>5</sup> / <sub>8</sub> "	<b>010-650-18</b>
---	-------------------

010-651-18

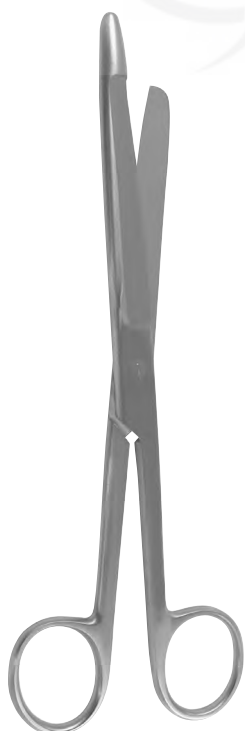

21,0 cm, 8<sup>1</sup>/<sub>4</sub>"  
**010-670-21**



21,0 cm, 8<sup>1</sup>/<sub>4</sub>"  
**010-672-21**



21,0 cm, 8<sup>1</sup>/<sub>4</sub>"  
**010-674-21**



**LLOYD-DAVIES**  
 27,0 cm, 10<sup>5</sup>/<sub>8</sub>"  
**010-677-27**



Lungenlappen- und Rektumscheren, Lungenscheren, Dammscheren  
 Lobectomy and Rectal Scissors, Lobectomy Scissors, Episiotor  
 Tijeras para lobectomía y recto, Tijera para lobectomía, Tijeras p  
 Forbici per lobo polmonare e per il retto, Forbici per lobo, Forbic

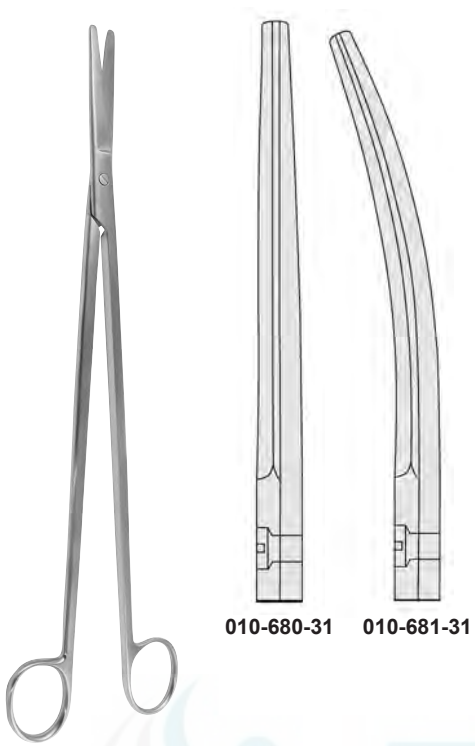

010-680-31 010-681-31

**STELZNER**  
 31,0 cm, 12<sup>1</sup>/<sub>4</sub>"

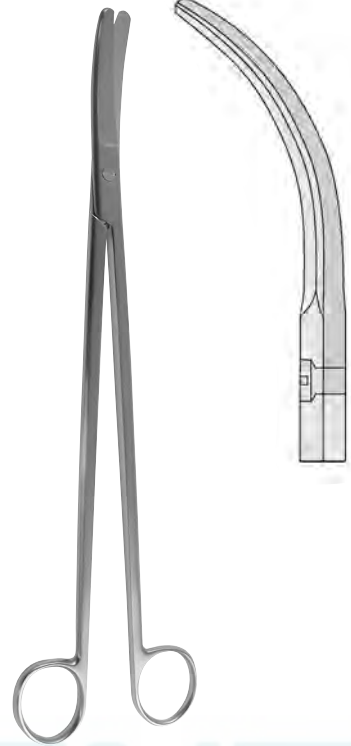

**RECTAL**  
 32,5 cm, 12<sup>3</sup>/<sub>4</sub>"  
 010-685-32

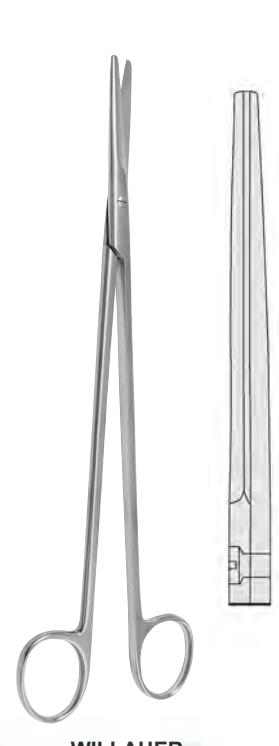

**WILLAUER**  
 25,0 cm, 9<sup>3</sup>/<sub>4</sub>" 010-688-25  
 28,0 cm, 11" 010-688-28

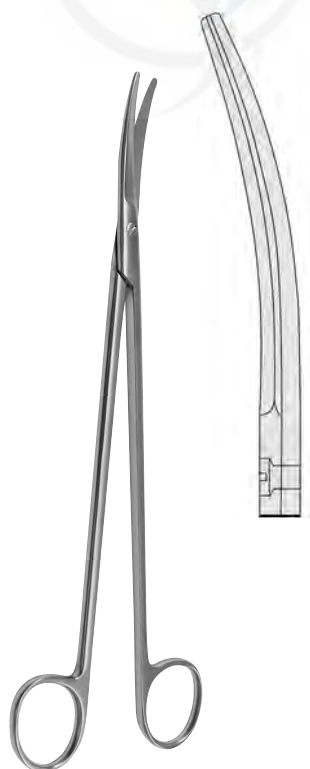

**WILLAUER**  
 25,0 cm, 9<sup>3</sup>/<sub>4</sub>" 010-689-25  
 28,0 cm, 11" 010-689-28

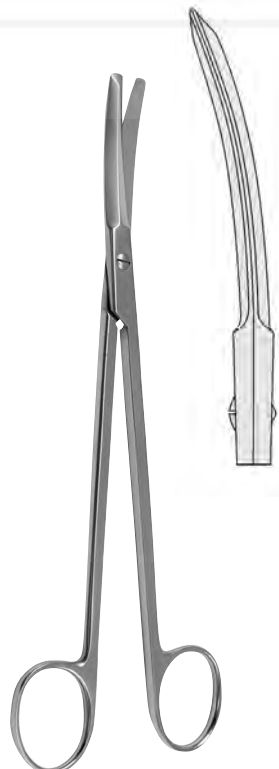

**POTTS-SMITH**  
 19,0 cm, 7<sup>1</sup>/<sub>2</sub>"  
 010-691-19

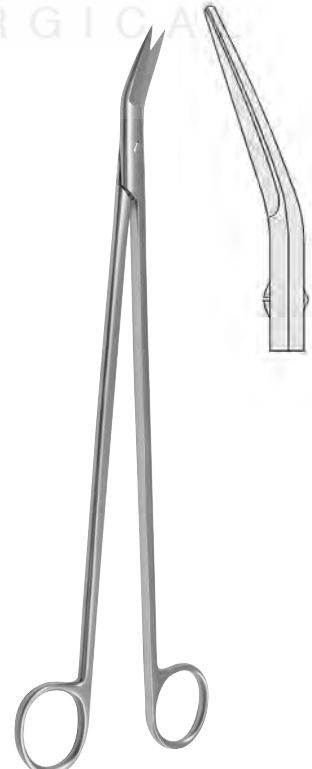

**FINOCHIETTO**  
 32,5 cm, 10<sup>5</sup>/<sub>8</sub>"  
 010-693-27



**WALDMANN**  
18,0 cm, 7"  
010-695-18



**BRAUN-STADLER**  
14,5 cm, 5<sup>3</sup>/<sub>4</sub>"    010-701-14  
20,0 cm, 8"        010-701-20



20,0 cm, 8"  
010-703-20



**MOD. USA**  
10,5 cm, 4<sup>1</sup>/<sub>8</sub>"  
010-706-10



**BUSCH**  
13,5 cm, 5<sup>3</sup>/<sub>8</sub>"    010-707-13  
16,0 cm, 6<sup>1</sup>/<sub>4</sub>"    010-707-16



**SCHUMACHER**  
16,0 cm, 16<sup>1</sup>/<sub>4</sub>"  
010-709-16



gezahnt  
 serrated  
 dentada  
 dentata

**UNIVERSAL**  
 12,0 cm, 4<sup>3</sup>/<sub>4</sub>"  
 010-800-12



**LISTER**

9,0 cm, 3 <sup>1</sup> / <sub>2</sub> "	<b>010-900-09</b>
11,0 cm, 4 <sup>3</sup> / <sub>8</sub> "	<b>010-900-11</b>
14,0 cm, 5 <sup>1</sup> / <sub>2</sub> "	<b>010-900-14</b>
18,0 cm, 7"	<b>010-900-18</b>
20,0 cm, 8"	<b>010-900-20</b>



**LISTER**

18,5 cm, 7 <sup>1</sup> / <sub>4</sub> "	<b>010-901-18</b>
21,0 cm, 8 <sup>1</sup> / <sub>4</sub> "	<b>010-901-21</b>

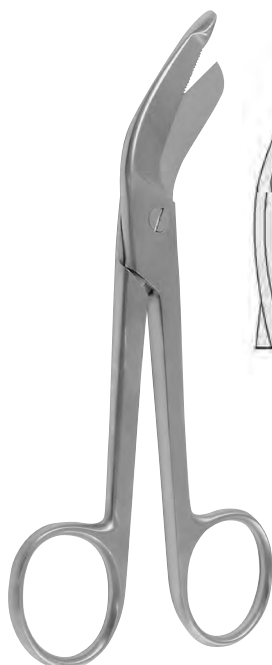

**LISTER-EXCENTRIC**

16,0 cm, 6 <sup>1</sup> / <sub>4</sub> "	<b>010-903-16</b>
19,0 cm, 7 <sup>1</sup> / <sub>2</sub> "	<b>010-903-19</b>

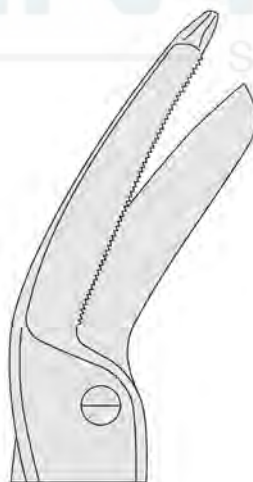

gezahnt  
 serrated  
 dentada  
 dentata



**BERGMANN**

23,0 cm, 9"	<b>010-905-23</b>
-------------	-------------------

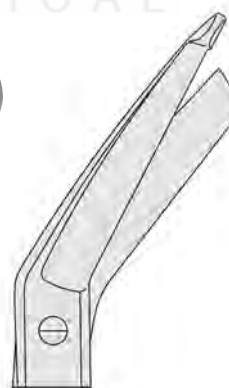

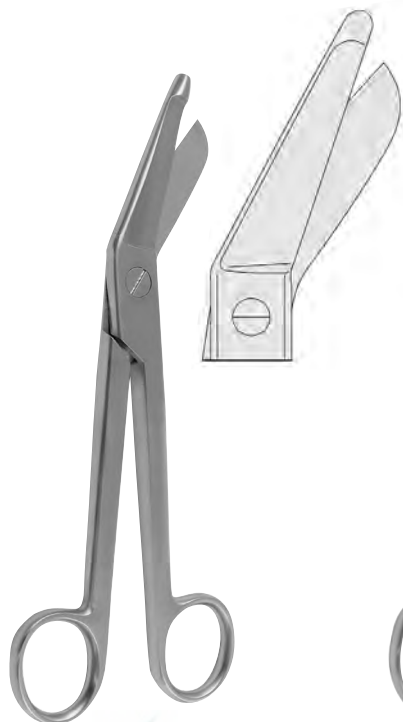

**ESMARCH**  
 20,0 cm, 8" **010-907-20**  
 22,0 cm, 8<sup>5</sup>/<sub>8</sub>" **010-907-22**



**KNOWLES**  
 14,0 cm, 5<sup>1</sup>/<sub>2</sub>"  
**010-920-14**

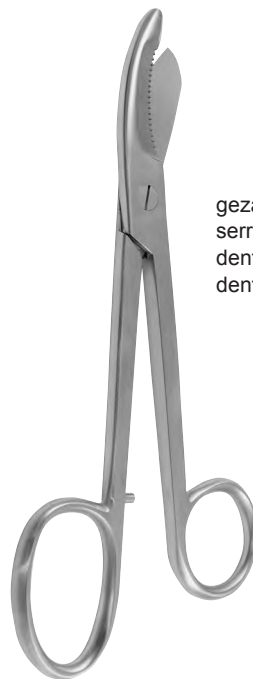

**BRUNS**  
 24,0 cm, 9<sup>1</sup>/<sub>2</sub>"  
**010-909-24**  
**010-910-24**

gezahnt  
 serrated  
 dentada  
 dentata



**LORENZ**  
 23,0 cm, 9"  
**010-930-23**

bis 134°C autoklavierbar  
 autoclavable up to 134°C  
 esterilizable en autoclave hasta 134°C  
 Sterilizzabile in autoclave fino 134°C

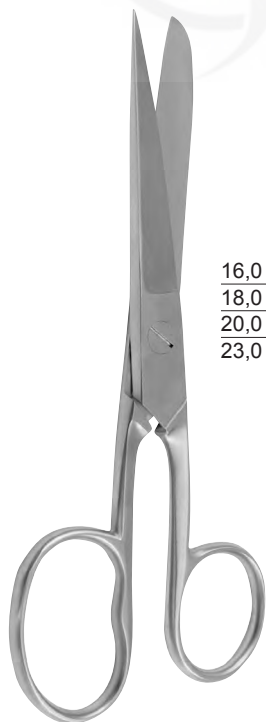

**SMITH**  
 (MOD. USA)

16,0 cm, 6<sup>1</sup>/<sub>4</sub>" **010-940-16**  
 18,0 cm, 7" **010-940-18**  
 20,0 cm, 8" **010-940-20**  
 23,0 cm, 9" **010-940-23**



gezahnt  
 serrated  
 dentada  
 dentata

20,0 cm, 8"  
**010-941-20**



gezahnt  
 serrated  
 dentada  
 dentata

**UNIVERSAL**  
 14,0 cm, 5<sup>1</sup>/<sub>2</sub>" **010-950-14**  
 16,0 cm, 6<sup>1</sup>/<sub>4</sub>" **010-950-16**  
 18,0 cm, 7" **010-950-18**

Chirurgische Scheren mit Hartmetallschneiden  
 Surgical Scissors with tungsten carbide edges  
 Tijeras para cirugía con filos de carburo tungsteno  
 Forbici per chirurgia con lame in carburo di tungsteno

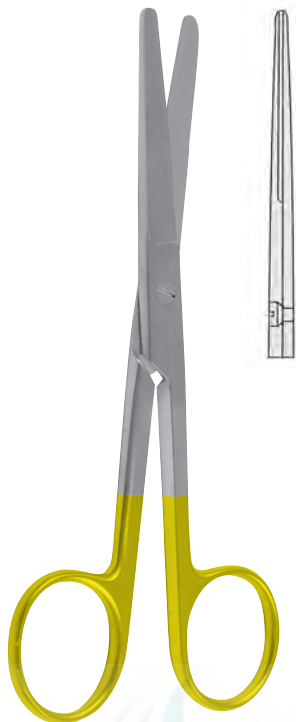

**STANDARD**

14,5 cm, 5 <sup>3</sup> / <sub>4</sub> "	<b>011-000-14</b>
16,5 cm, 6 <sup>1</sup> / <sub>2</sub> "	<b>011-000-16</b>
18,5 cm, 7 <sup>1</sup> / <sub>4</sub> "	<b>011-000-18</b>

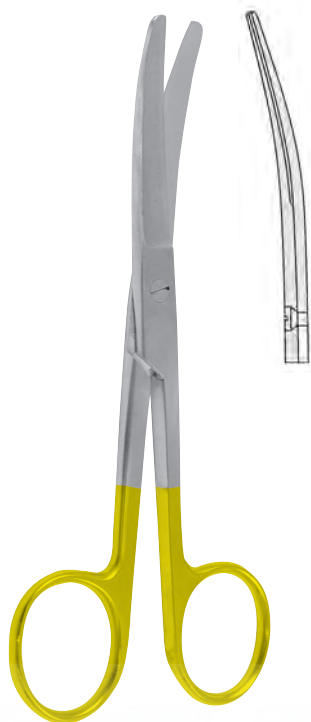

**STANDARD**

14,5 cm, 5 <sup>3</sup> / <sub>4</sub> "	<b>011-001-14</b>
16,5 cm, 6 <sup>1</sup> / <sub>2</sub> "	<b>011-001-16</b>
18,5 cm, 7 <sup>1</sup> / <sub>4</sub> "	<b>011-001-18</b>

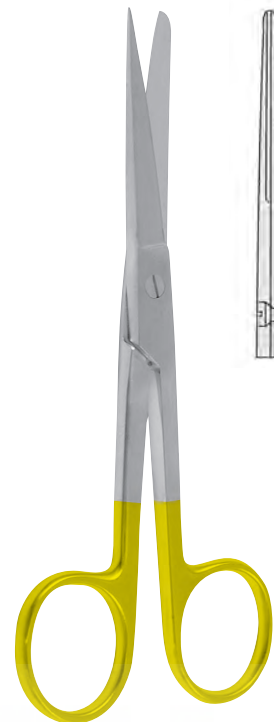

**STANDARD**

14,5 cm, 5 <sup>3</sup> / <sub>4</sub> "	<b>011-002-14</b>
16,5 cm, 6 <sup>1</sup> / <sub>2</sub> "	<b>011-002-16</b>
18,5 cm, 7 <sup>1</sup> / <sub>4</sub> "	<b>011-002-18</b>

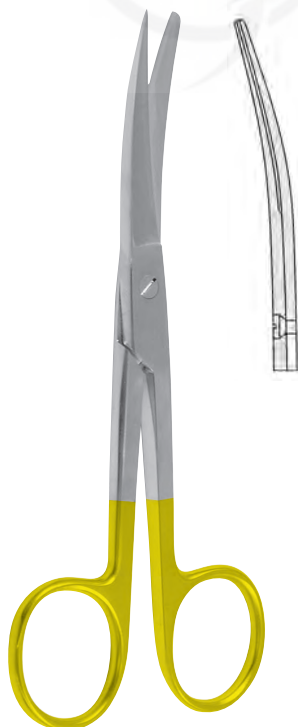

**STANDARD**

14,5 cm, 5 <sup>3</sup> / <sub>4</sub> "	<b>011-003-14</b>
16,5 cm, 6 <sup>1</sup> / <sub>2</sub> "	<b>011-003-16</b>
18,5 cm, 7 <sup>1</sup> / <sub>4</sub> "	<b>011-003-18</b>

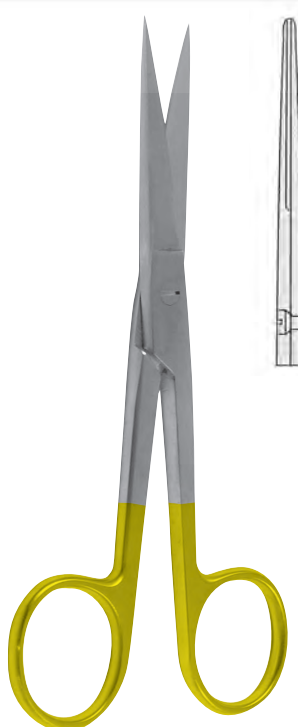

**STANDARD**

14,5 cm, 5 <sup>3</sup> / <sub>4</sub> "	<b>011-004-14</b>
16,5 cm, 6 <sup>1</sup> / <sub>2</sub> "	<b>011-004-16</b>
18,5 cm, 7 <sup>1</sup> / <sub>4</sub> "	<b>011-004-18</b>

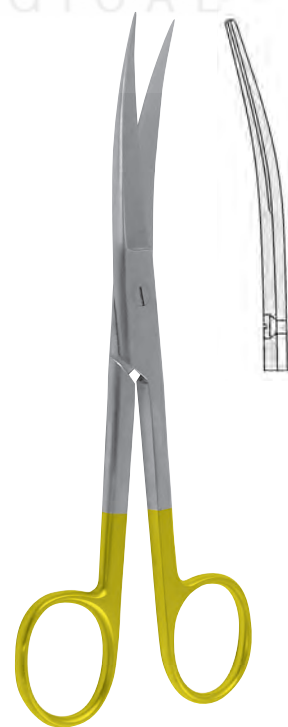

**STANDARD**

14,5 cm, 5 <sup>3</sup> / <sub>4</sub> "	<b>011-005-14</b>
16,5 cm, 6 <sup>1</sup> / <sub>2</sub> "	<b>011-005-16</b>
18,5 cm, 7 <sup>1</sup> / <sub>4</sub> "	<b>011-005-18</b>



**MAYO**

14,5 cm, 5 <sup>3</sup> / <sub>4</sub> "	<b>011-100-14</b>
17,0 cm, 6 <sup>3</sup> / <sub>4</sub> "	<b>011-100-17</b>
23,0 cm, 9"	<b>011-100-23</b>



**MAYO**

14,5 cm, 5 <sup>3</sup> / <sub>4</sub> "	<b>011-101-14</b>
17,0 cm, 6 <sup>3</sup> / <sub>4</sub> "	<b>011-101-17</b>
23,0 cm, 9"	<b>011-101-23</b>

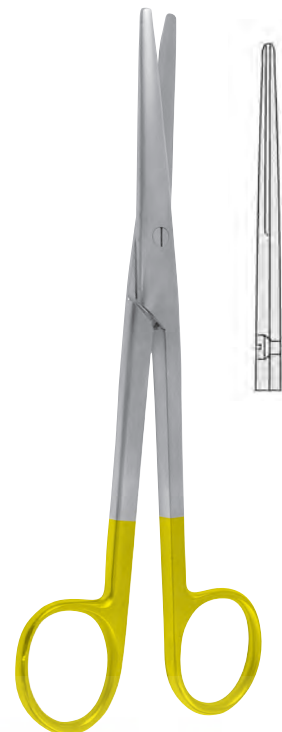

**MAYO-STILLE**

15,0 cm, 6"	<b>011-102-15</b>
17,0 cm, 6 <sup>3</sup> / <sub>4</sub> "	<b>011-102-17</b>

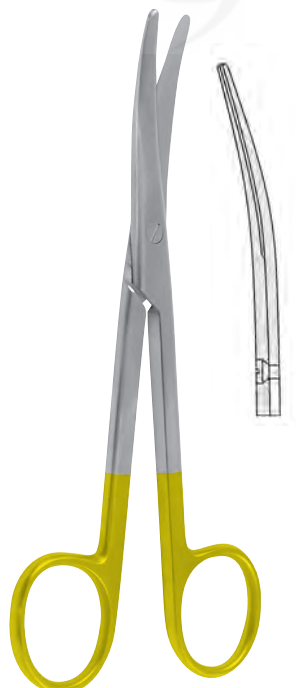

**MAYO-STILLE**

15,0 cm, 6"	<b>011-103-15</b>
17,0 cm, 6 <sup>3</sup> / <sub>4</sub> "	<b>011-103-17</b>

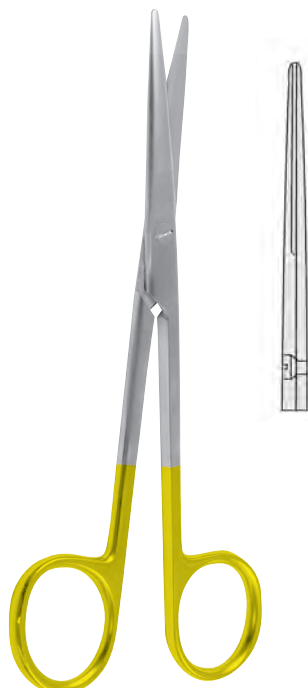

**LEXER**

16,0 cm, 6 <sup>1</sup> / <sub>4</sub> "	<b>011-140-16</b>
21,0 cm, 8 <sup>1</sup> / <sub>4</sub> "	<b>011-140-21</b>

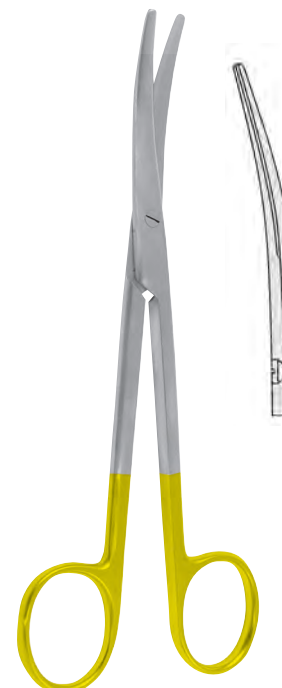

**LEXER**

16,0 cm, 6 <sup>1</sup> / <sub>4</sub> "	<b>011-141-16</b>
21,0 cm, 8 <sup>1</sup> / <sub>4</sub> "	<b>011-141-21</b>

Präparierscheren mit Hartmetallschneiden  
 Dissecting Scissors with tungsten carbide edges  
 Tijeras para disección con filos de carburo tungsteno  
 Forbici per dissezione con lame in carburo di tungsteno



**BABY-METZENBAUM**  
 11,5 cm, 4 1/2"

**METZENBAUM**  
 14,5 cm, 5 3/4"

**METZENBAUM**  
 14,5 cm, 5 3/4"

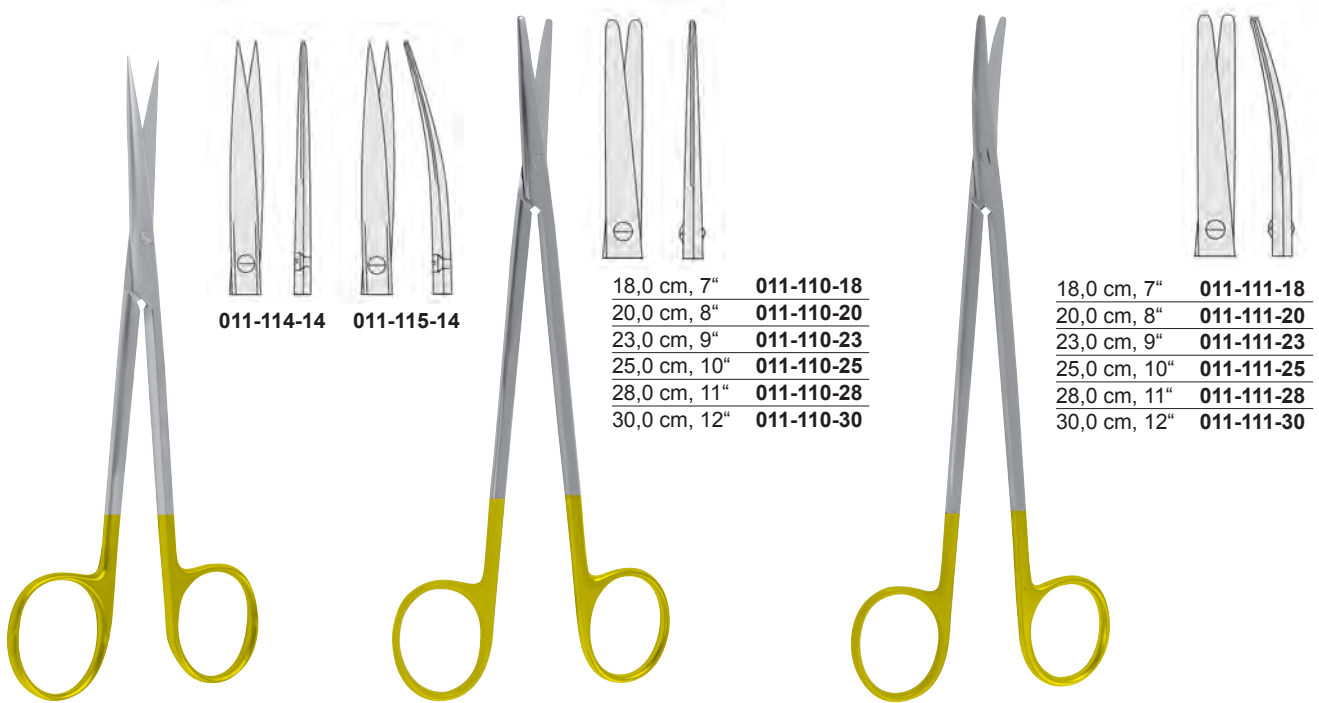

**METZENBAUM**  
 14,5 cm, 5 3/4"

**METZENBAUM**

**METZENBAUM**

011-114-14 011-115-14

18,0 cm, 7" 011-110-18  
 20,0 cm, 8" 011-110-20  
 23,0 cm, 9" 011-110-23  
 25,0 cm, 10" 011-110-25  
 28,0 cm, 11" 011-110-28  
 30,0 cm, 12" 011-110-30

18,0 cm, 7" 011-111-18  
 20,0 cm, 8" 011-111-20  
 23,0 cm, 9" 011-111-23  
 25,0 cm, 10" 011-111-25  
 28,0 cm, 11" 011-111-28  
 30,0 cm, 12" 011-111-30

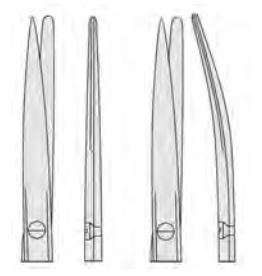
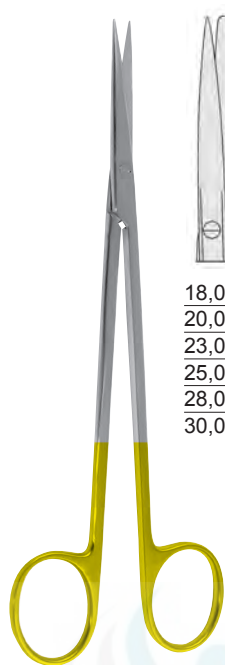

18,0 cm, 7"	<b>011-112-18</b>
20,0 cm, 8"	<b>011-112-20</b>
23,0 cm, 9"	<b>011-112-23</b>
25,0 cm, 10"	<b>011-112-25</b>
28,0 cm, 11"	<b>011-112-28</b>
30,0 cm, 12"	<b>011-112-30</b>

**METZENBAUM**

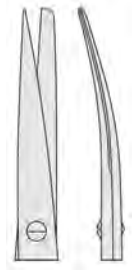
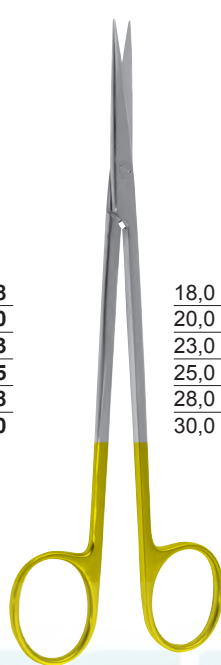

18,0 cm, 7"	<b>011-113-18</b>
20,0 cm, 8"	<b>011-113-20</b>
23,0 cm, 9"	<b>011-113-23</b>
25,0 cm, 10"	<b>011-113-25</b>
28,0 cm, 11"	<b>011-113-28</b>
30,0 cm, 12"	<b>011-113-30</b>

**METZENBAUM**

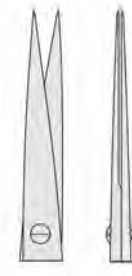
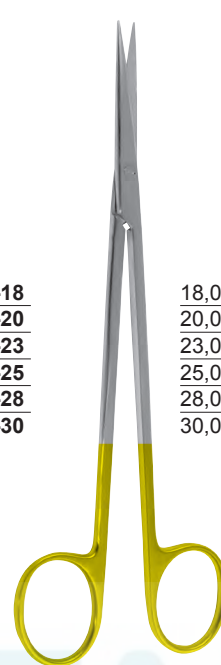

18,0 cm, 7"	<b>011-114-18</b>
20,0 cm, 8"	<b>011-114-20</b>
23,0 cm, 9"	<b>011-114-23</b>
25,0 cm, 10"	<b>011-114-25</b>
28,0 cm, 11"	<b>011-114-28</b>
30,0 cm, 12"	<b>011-114-30</b>

**METZENBAUM**

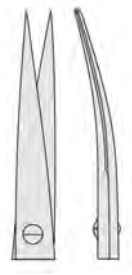
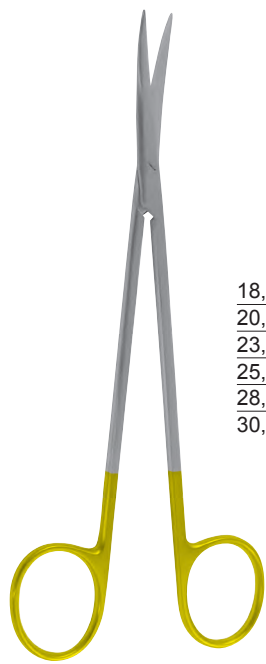

18,0 cm, 7"	<b>011-115-18</b>
20,0 cm, 8"	<b>011-115-20</b>
23,0 cm, 9"	<b>011-115-23</b>
25,0 cm, 10"	<b>011-115-25</b>
28,0 cm, 11"	<b>011-115-28</b>
30,0 cm, 12"	<b>011-115-30</b>

**METZENBAUM**

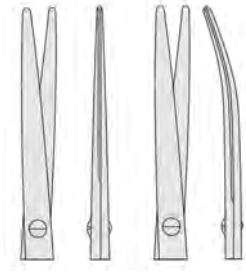
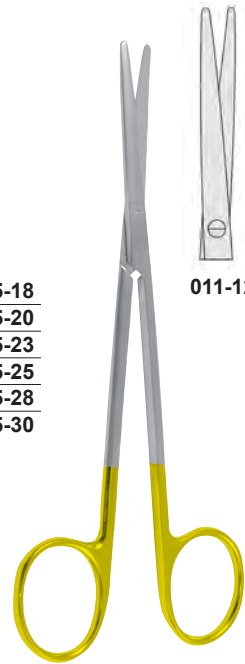

**011-120-14 011-121-14**

**METZENBAUM-FINO**  
14,5 cm, 5<sup>3</sup>/<sub>4</sub>"

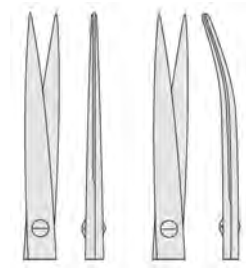
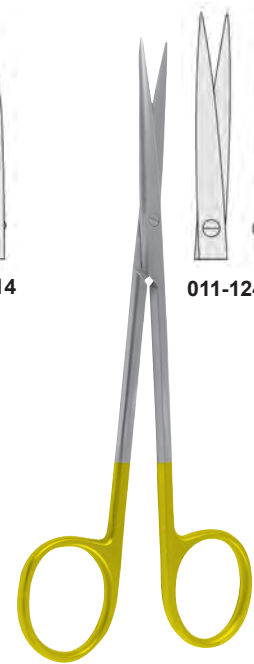

**011-124-14 011-125-14**

**METZENBAUM-FINO**  
14,5 cm, 5<sup>3</sup>/<sub>4</sub>"

Präparierscheren mit Hartmetallschneiden  
 Dissecting Scissors with tungsten carbide edges  
 Tijeras para disección con filos de carburo tungsteno  
 Forbici per dissezione con lame in carburo di tungsteno

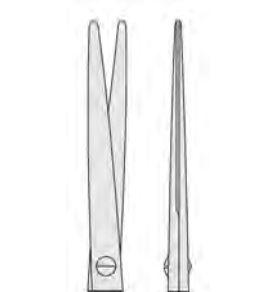
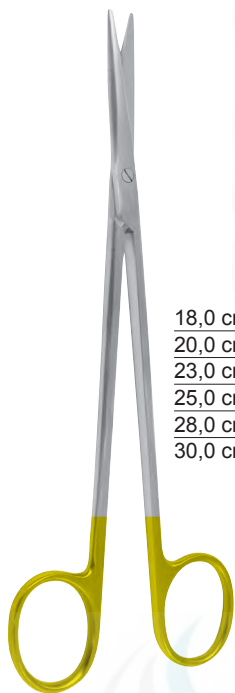

18,0 cm, 7" **011-120-18**  
 20,0 cm, 8" **011-120-20**  
 23,0 cm, 9" **011-120-23**  
 25,0 cm, 10" **011-120-25**  
 28,0 cm, 11" **011-120-28**  
 30,0 cm, 12" **011-120-30**

**METZENBAUM-FINO**

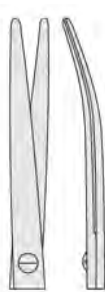
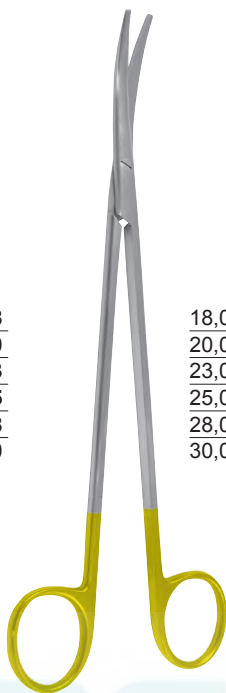

18,0 cm, 7" **011-121-18**  
 20,0 cm, 8" **011-121-20**  
 23,0 cm, 9" **011-121-23**  
 25,0 cm, 10" **011-121-25**  
 28,0 cm, 11" **011-121-28**  
 30,0 cm, 12" **011-121-30**

**METZENBAUM-FINO**

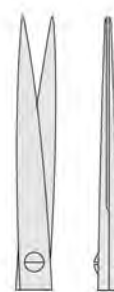
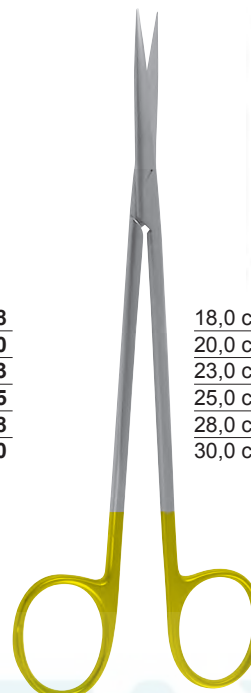

18,0 cm, 7" **011-124-18**  
 20,0 cm, 8" **011-124-20**  
 23,0 cm, 9" **011-124-23**  
 25,0 cm, 10" **011-124-25**  
 28,0 cm, 11" **011-124-28**  
 30,0 cm, 12" **011-124-30**

**METZENBAUM-FINO**

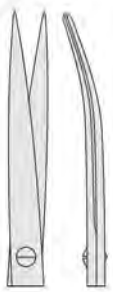
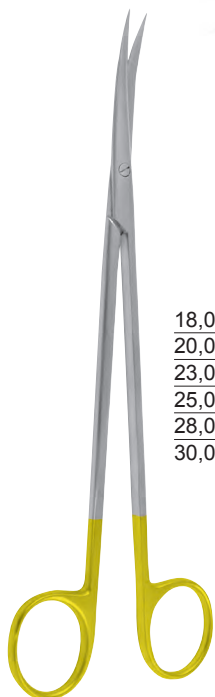

18,0 cm, 7" **011-125-18**  
 20,0 cm, 8" **011-125-20**  
 23,0 cm, 9" **011-125-23**  
 25,0 cm, 10" **011-125-25**  
 28,0 cm, 11" **011-125-28**  
 30,0 cm, 12" **011-125-30**

**METZENBAUM-FINO**

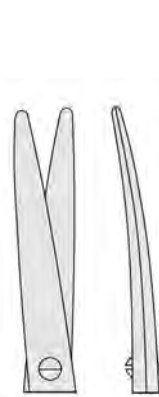
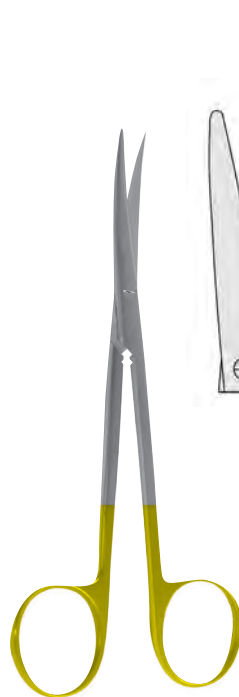

**METZENBAUM-LAHEY**  
 14,0 cm, 5 1/2"  
**011-137-14**

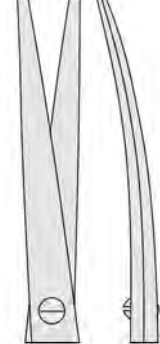
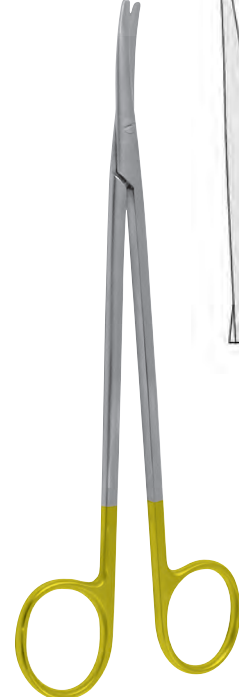

**TOENNIS-ADSON**  
 17,0 cm, 6 3/4"  
**011-139-17**

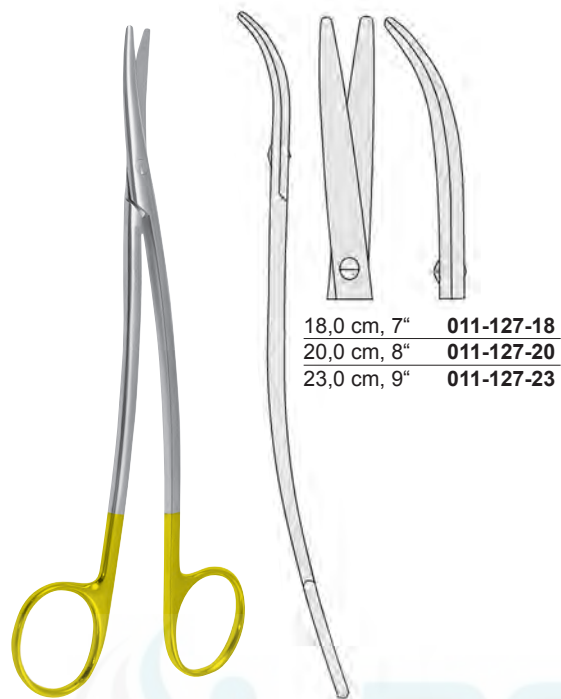

**METZENBAUM-FINO S**

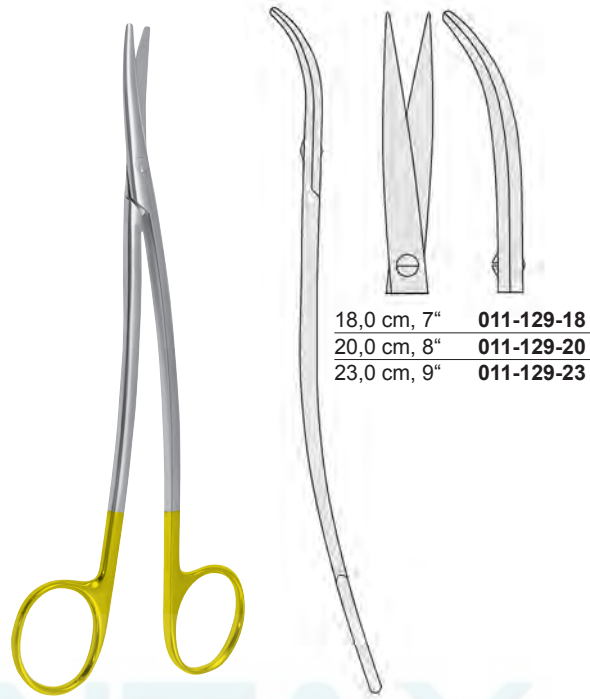

**METZENBAUM-FINO S**

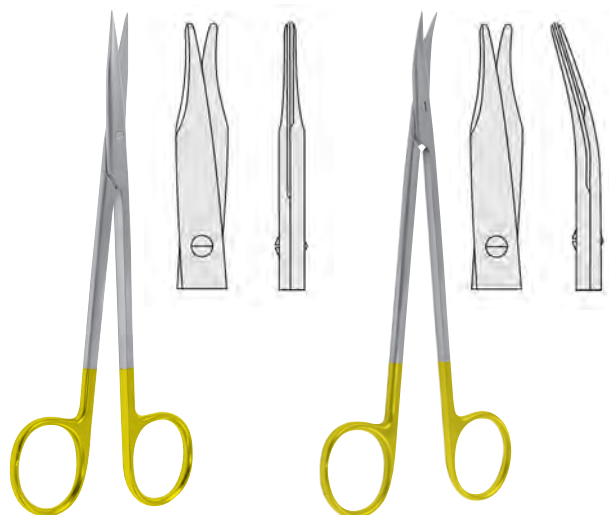

**REYNOLDS**  
15,0 cm, 6"  
**011-210-15**

**REYNOLDS**  
15,0 cm, 6"  
**011-211-15**



**HYSTEREKTOMY**  
25,5 cm, 10"  
**011-663-25**

**HYSTEREKTOMY**  
25,0 cm, 9<sup>3</sup>/<sub>4</sub>"  
**011-665-25**

Gynäkologische Scheren mit Hartmetallschneiden  
 Gynecology Scissors with tungsten carbide edges  
 Tijeras para ginecología con filos de carburo tungsteno  
 Forbici per ginecologia con lame in carburo di tungsteno



SIMS

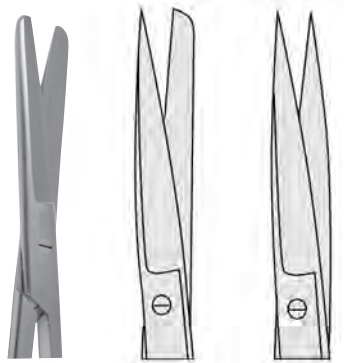

20,0 cm, 8"	011-600-20	011-602-20	011-604-20
23,0 cm, 9"	011-600-23	011-602-23	011-604-23



SIMS

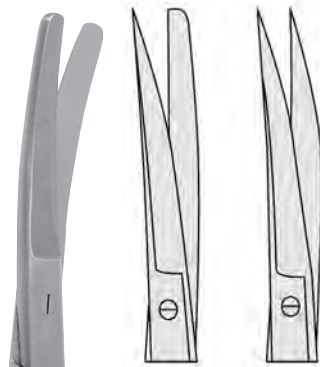

20,0 cm, 8"	011-601-20	011-603-20	011-605-20
23,0 cm, 9"	011-601-23	011-603-23	011-605-23



**DIETRICH**  
 17,5 cm, 6<sup>7</sup>/<sub>8</sub>"  
 011-552-17

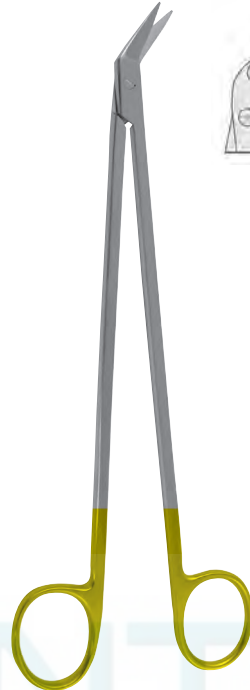

**POTTS DE MARTEL**  
 24,0 cm, 9<sup>1</sup>/<sub>2</sub>"  
 011-548-24



**DE BAKEY**

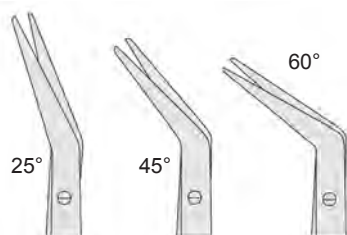

20,0 cm, 8"	<b>011-543-25</b>	<b>011-543-45</b>	<b>011-543-60</b>
23,0 cm, 9"	<b>011-545-25</b>	<b>011-545-45</b>	<b>011-545-60</b>

Gefäßscheren mit Hartmetallschneiden  
Vascular Scissors with tungsten carbide edges  
Tijeras vasculares con filos de carburo tungsteno  
Forbici vascolari con lame in carburo di tungsteno

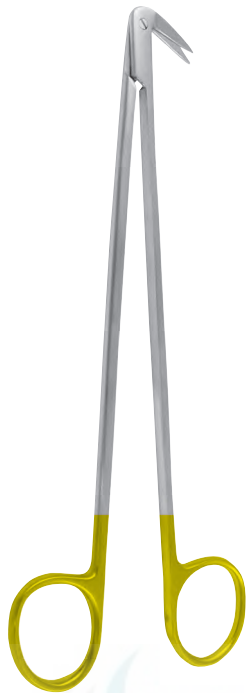

**DIETHRICH-HEGEMANN**  
18,0 cm, 7"

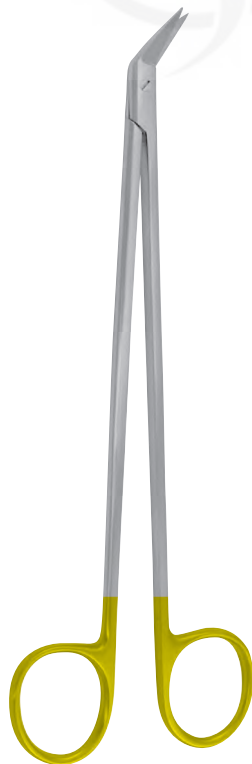

**POTTS-SMITH**  
18,0 cm, 7 1/2"

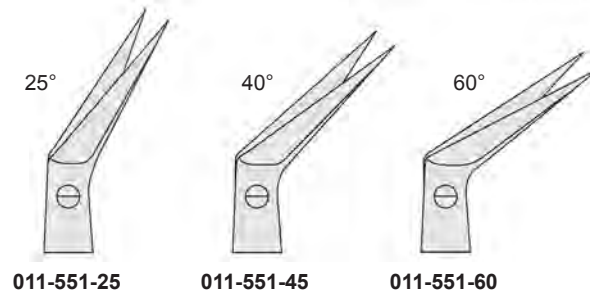

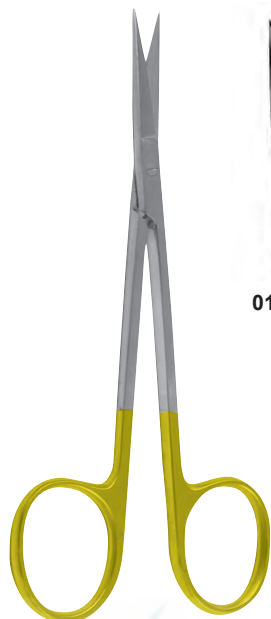

**IRIS**  
11,5 cm, 4 1/2"

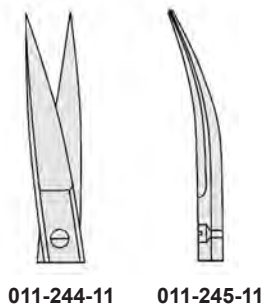

011-244-11    011-245-11

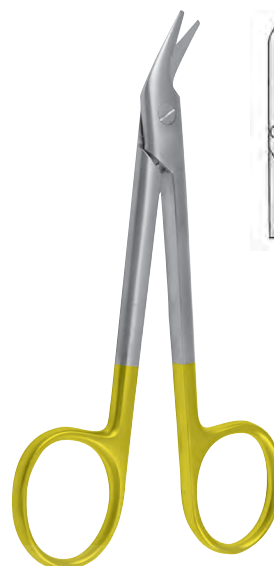

**UNIVERSAL**  
12,0 cm, 4 3/4"  
011-800-12

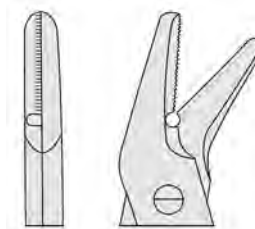

gezahnt  
serrated  
dentada  
dentata

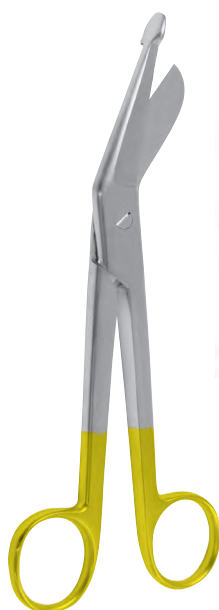

**LISTER**  
18,0 cm, 7"  
011-900-18

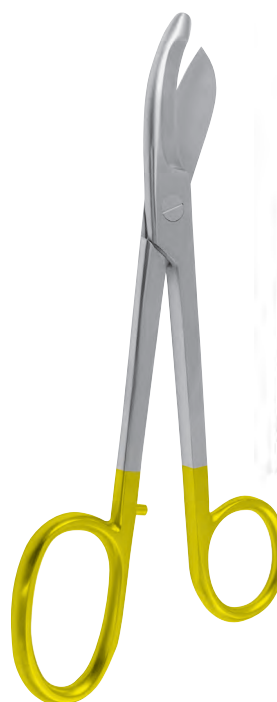
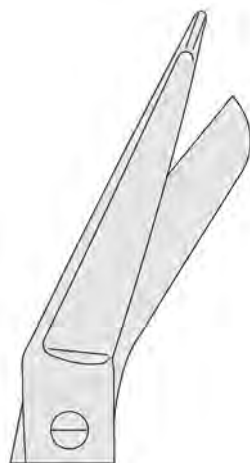

**BRUNS**  
24,0 cm, 9 1/2"  
011-909-24

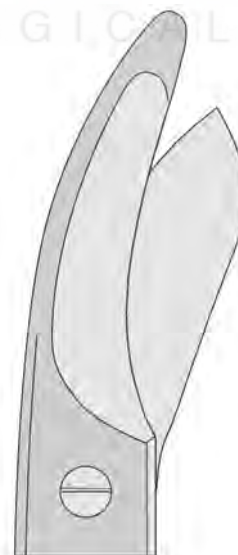

Super-Cut Scheren  
 Super-Cut Scissors  
 Tijeras Super-Cut  
 Forbici Super-Cut

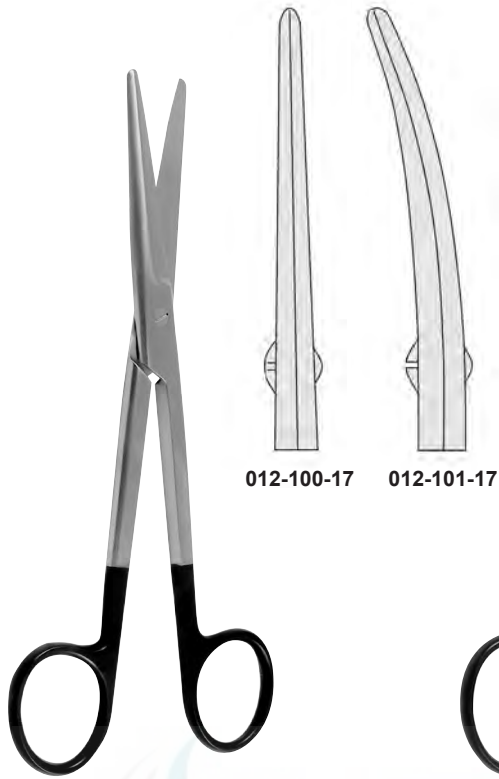

012-100-17 012-101-17

**MAYO**  
 17,0 cm, 6<sup>3</sup>/<sub>4</sub>"

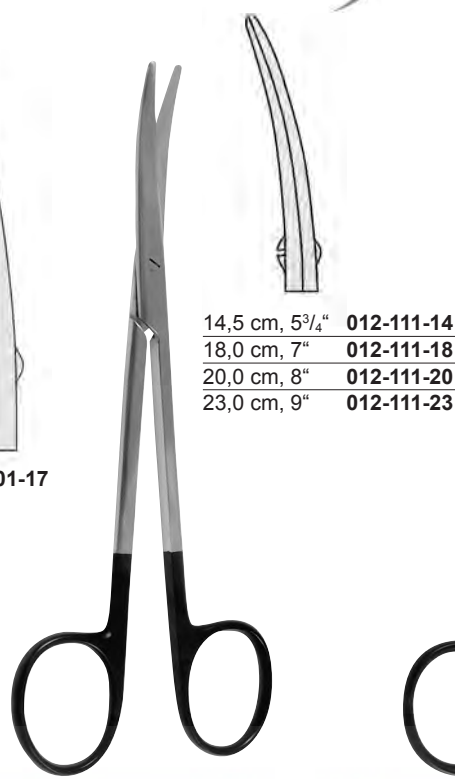

14,5 cm, 5<sup>3</sup>/<sub>4</sub>" 012-111-14  
 18,0 cm, 7" 012-111-18  
 20,0 cm, 8" 012-111-20  
 23,0 cm, 9" 012-111-23

**METZENBAUM**

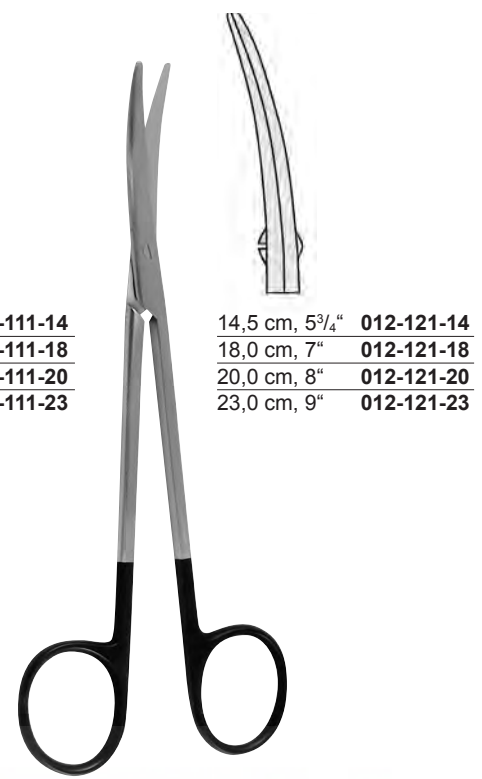

14,5 cm, 5<sup>3</sup>/<sub>4</sub>" 012-121-14  
 18,0 cm, 7" 012-121-18  
 20,0 cm, 8" 012-121-20  
 23,0 cm, 9" 012-121-23

**METZENBAUM-FINO**



15,0 cm, 6" 012-129-15  
 19,0 cm, 7<sup>1</sup>/<sub>2</sub>" 012-129-19

**KAYE FACE LIFT**

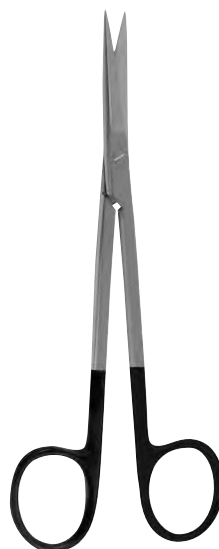

**JABALEY**  
 13,0 cm, 5"  
 012-130-13

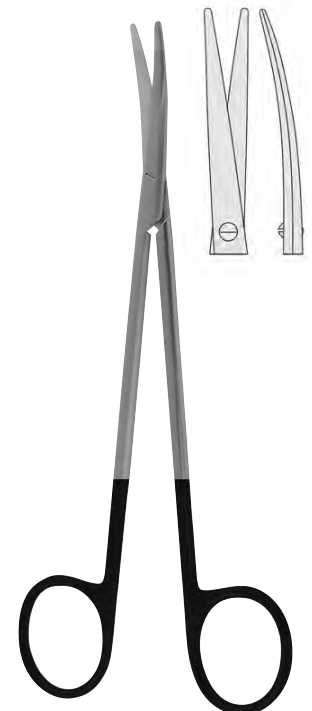

**TOENNIS-ADSON**  
 17,0 cm, 6<sup>3</sup>/<sub>4</sub>"  
 012-139-17

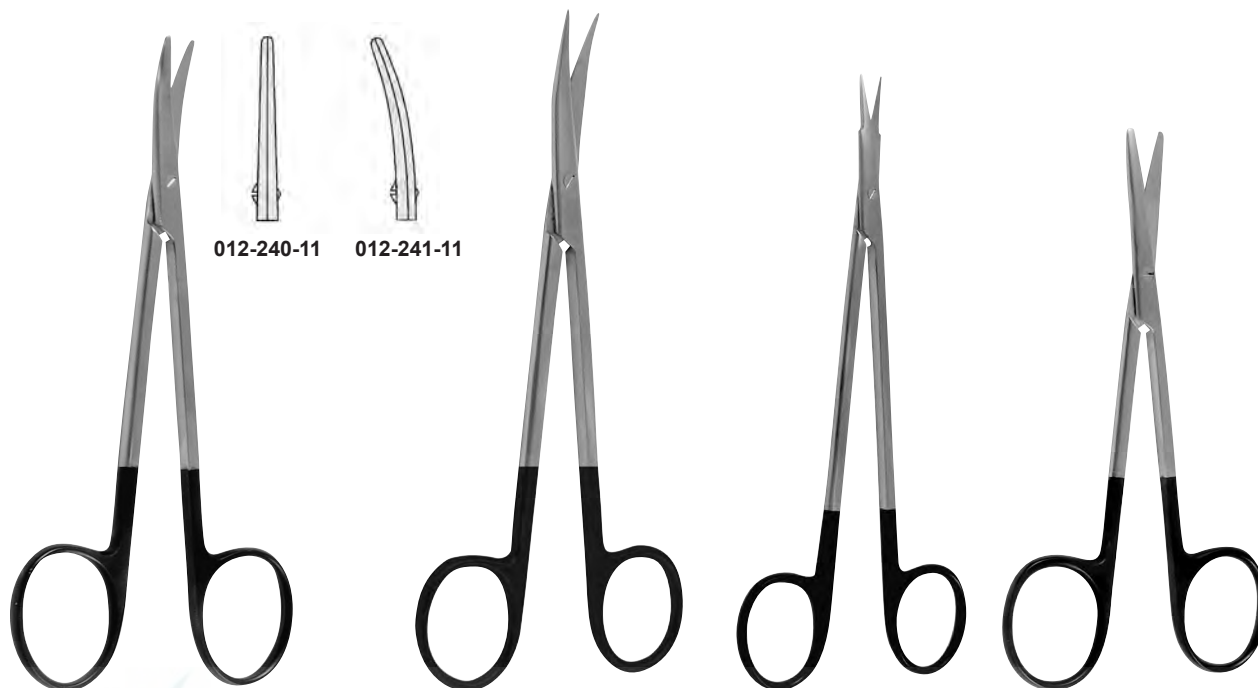

**STRABISMUS**  
11,5 cm, 4 $\frac{1}{2}$ "

**JAMISON**  
15,0 cm, 6"     **012-218-15**  
18,0 cm, 7"     **012-218-18**

**REYNOLDS**  
12,5 cm, 5"  
**012-210-12**

**BABY-METZENBAUM**  
11,0 cm, 4 $\frac{3}{8}$ "     **012-110-11**  
14,5 cm, 5 $\frac{3}{4}$ "     **012-110-14**



**IRIS**  
11,0 cm, 4 $\frac{3}{8}$ "  
**012-244-11**



**IRIS**  
11,0 cm, 4 $\frac{3}{8}$ "  
**012-245-11**

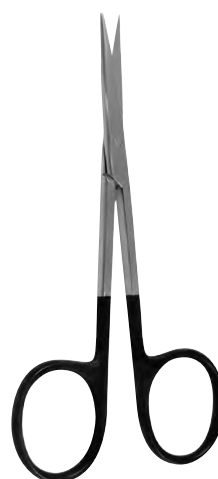

**STEVENS TENOTOMY**  
11,0 cm, 4 $\frac{3}{8}$ "  
**012-290-11**



**STEVENS T ENOTOMY**  
11,0 cm, 4 $\frac{3}{8}$ "  
**012-291-11**

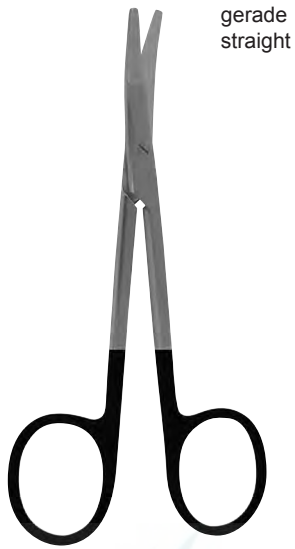

gerade  
straight

**PAR TYPE**  
 12,0 cm, 4<sup>3</sup>/<sub>4</sub>"  
 012-200-12



gebogen  
curved

**PAR TYPE**  
 12,0 cm, 4<sup>3</sup>/<sub>4</sub>"  
 012-201-12

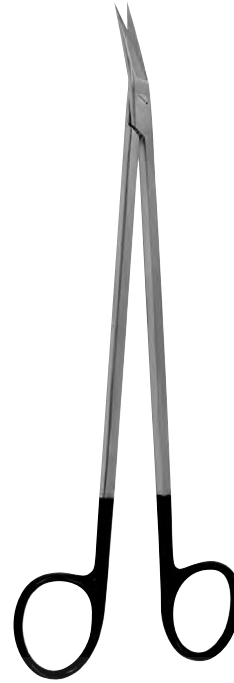

**POTTS**  
 19,0 cm, 7<sup>1</sup>/<sub>2</sub>"



012-551-25



012-551-45

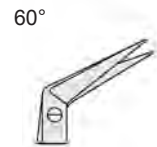

012-551-60



**FOMON**  
 14,5 cm, 5<sup>3</sup>/<sub>4</sub>"  
 012-343-15



**COTTLE**  
 16,5 cm, 6<sup>1</sup>/<sub>2</sub>"  
 012-511-16

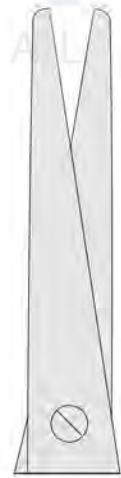

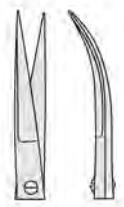

018-081-11

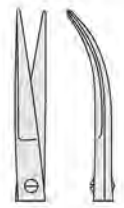

018-083-11

**WESTCOTT**  
11,0 cm, 4<sup>3</sup>/<sub>8</sub>"



gezahnt  
serrated  
dentada  
dentata

**GOMEL**

14,0 cm, 5<sup>1</sup>/<sub>2</sub>"    **018-241-14Z**  
16,0 cm, 6<sup>1</sup>/<sub>4</sub>"    **018-241-16Z**

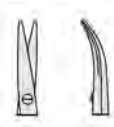

Mikro-Präparierscheren  
Micro-dissecting scissors  
Micro-tijeras de disección  
Micro-forbici per dissezione

**HEPP SCHEIDEL**

14,0 cm, 5<sup>1</sup>/<sub>2</sub>"    **018-243-14**  
16,0 cm, 6<sup>1</sup>/<sub>4</sub>"    **018-243-16**

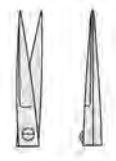
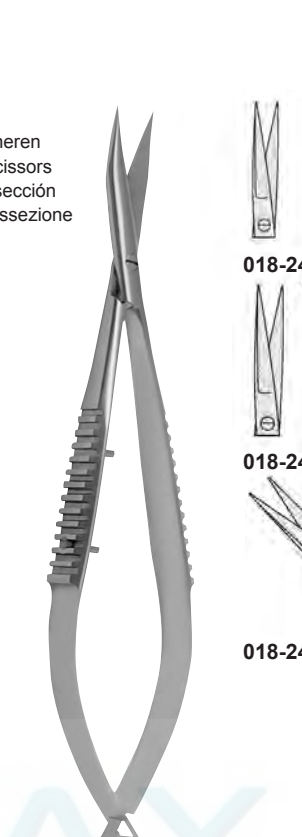

018-246-01

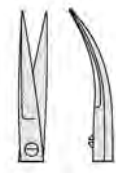

018-246-02



018-246-03

18,5 cm, 7<sup>1</sup>/<sub>4</sub>"



**STEVENS**



18,5 cm, 7<sup>1</sup>/<sub>4</sub>"    **018-290-01**    **018-290-02**    **018-290-03**    **018-290-04**  
22,5 cm, 8<sup>3</sup>/<sub>4</sub>"    **018-291-01**    **018-291-02**    **018-291-03**    **018-291-04**



18,5 cm, 7<sup>1</sup>/<sub>4</sub>"    **018-292-01**    **018-292-02**  
22,5 cm, 8<sup>3</sup>/<sub>4</sub>"    **018-293-01**    **018-293-02**

Mikro-Scheren, Mikro-Disektionsscheren  
 Micro Scissors, Micro Dissecting Scissors  
 Micro-Tijeras, Micro-Tijeras de disección  
 Micro-Forbici, Micro-Forbici per dissezione



18,0 cm, 7"

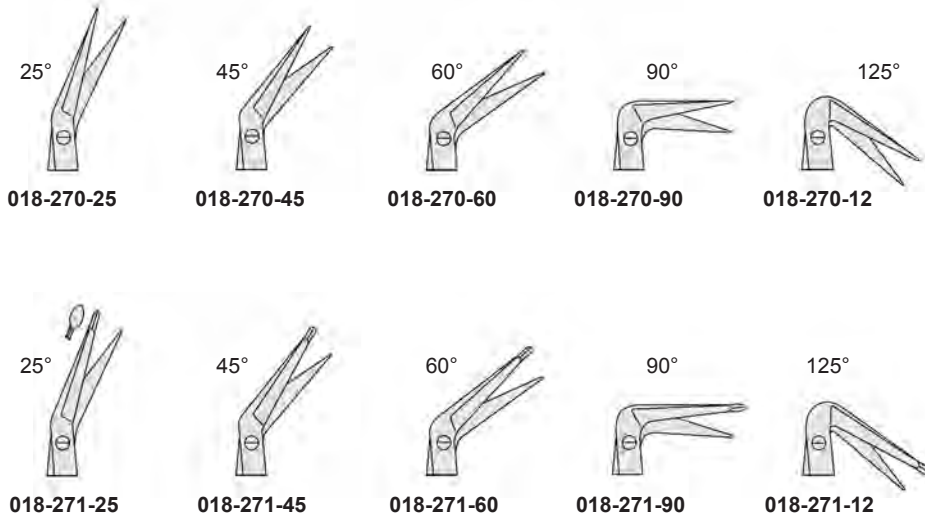

018-270-25

018-270-45

018-270-60

018-270-90

018-270-12

018-271-25

018-271-45

018-271-60

018-271-90

018-271-12



15,0 cm, 6"  
018-223-15



15,0 cm, 6"  
018-223-15Z

gezahnt  
serrated  
dentada  
dentata



15,0 cm, 6"  
018-201-15



18,0 cm, 7"  
018-201-18



15,0 cm, 6"  
018-232-15



15,0 cm, 6"  
018-232-15Z



gezahnt  
serrated  
dentada  
dentata



15,0 cm, 6"  
018-203-15

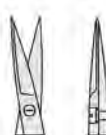

18,0 cm, 7"  
018-203-18

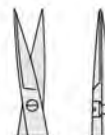

**Pinzetten**  
**Forceps**  
**Pinzas**  
**Pinze**

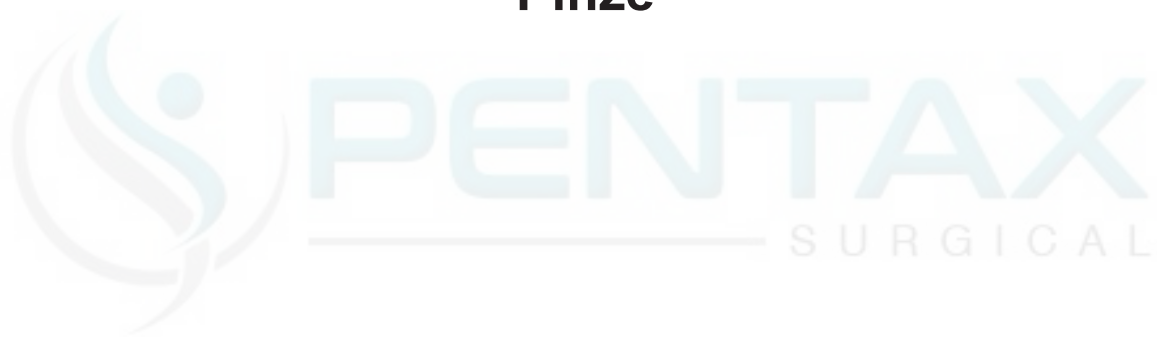



**STANDARD**

10,5 cm, 4 <sup>1</sup> / <sub>8</sub> "	<b>020-002-10</b>
11,5 cm, 4 <sup>1</sup> / <sub>2</sub> "	<b>020-002-11</b>
13,0 cm, 5"	<b>020-002-13</b>
14,5 cm, 5 <sup>3</sup> / <sub>4</sub> "	<b>020-002-14</b>
15,0 cm, 6"	<b>020-002-15</b>
16,0 cm, 6 <sup>1</sup> / <sub>4</sub> "	<b>020-002-16</b>
18,0 cm, 7"	<b>020-002-18</b>
20,0 cm, 8"	<b>020-002-20</b>
25,0 cm, 10"	<b>020-002-25</b>
30,0 cm, 12"	<b>020-002-30</b>



schmal  
 narrow  
 estrechos  
 stretti

**STANDARD**

10,5 cm, 4 <sup>1</sup> / <sub>8</sub> "	<b>020-003-10</b>
11,5 cm, 4 <sup>1</sup> / <sub>2</sub> "	<b>020-003-11</b>
13,0 cm, 5"	<b>020-003-13</b>
14,5 cm, 5 <sup>3</sup> / <sub>4</sub> "	<b>020-003-14</b>
15,0 cm, 6"	<b>020-003-15</b>
16,0 cm, 6 <sup>1</sup> / <sub>4</sub> "	<b>020-003-16</b>
18,0 cm, 7"	<b>020-003-18</b>
20,0 cm, 8"	<b>020-003-20</b>
25,0 cm, 10"	<b>020-003-25</b>
30,0 cm, 12"	<b>020-003-30</b>



schmal  
 narrow  
 estrechos  
 stretti

**STANDARD**

10,5 cm, 4 <sup>1</sup> / <sub>8</sub> "	<b>020-004-10</b>
11,5 cm, 4 <sup>1</sup> / <sub>2</sub> "	<b>020-004-11</b>
13,0 cm, 5"	<b>020-004-13</b>
14,5 cm, 5 <sup>3</sup> / <sub>4</sub> "	<b>020-004-14</b>
15,0 cm, 6"	<b>020-004-15</b>
16,0 cm, 6 <sup>1</sup> / <sub>4</sub> "	<b>020-004-16</b>
18,0 cm, 7"	<b>020-004-18</b>
20,0 cm, 8"	<b>020-004-20</b>
25,0 cm, 10"	<b>020-004-25</b>
30,0 cm, 12"	<b>020-004-30</b>

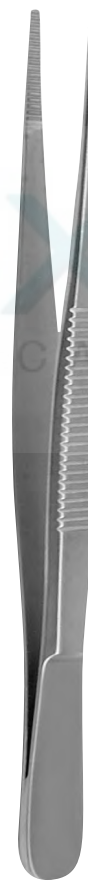

fein  
 fine  
 finas  
 fini

**STANDARD**

10,5 cm, 4 <sup>1</sup> / <sub>8</sub> "	<b>020-010-10</b>
11,5 cm, 4 <sup>1</sup> / <sub>2</sub> "	<b>020-010-11</b>
13,0 cm, 5"	<b>020-010-13</b>
14,5 cm, 5 <sup>3</sup> / <sub>4</sub> "	<b>020-010-14</b>
15,0 cm, 6"	<b>020-010-15</b>
16,0 cm, 6 <sup>1</sup> / <sub>4</sub> "	<b>020-010-16</b>
18,0 cm, 7"	<b>020-010-18</b>
20,0 cm, 8"	<b>020-010-20</b>
25,0 cm, 10"	<b>020-010-25</b>
30,0 cm, 12"	<b>020-010-30</b>



fein  
fine  
finas  
fini  
тонкие



fein  
fine  
finas  
fini

mit Stift  
with pin  
con perno  
con espiga

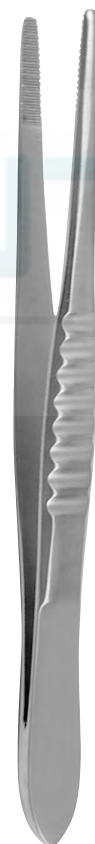

schmal  
narrow  
estrechos  
stretti  
узкие

10,5 cm, 4 <sup>1</sup> / <sub>8</sub> "	<b>020-011-10</b>
11,5 cm, 4 <sup>1</sup> / <sub>2</sub> "	<b>020-011-11</b>
13,0 cm, 5"	<b>020-011-13</b>
14,5 cm, 5 <sup>3</sup> / <sub>4</sub> "	<b>020-011-14</b>
16,0 cm, 6 <sup>1</sup> / <sub>4</sub> "	<b>020-011-16</b>
18,0 cm, 7"	<b>020-011-18</b>
20,0 cm, 8"	<b>020-011-20</b>
25,0 cm, 10"	<b>020-011-25</b>
30,0 cm, 12"	<b>020-011-30</b>

10,5 cm, 4 <sup>1</sup> / <sub>8</sub> "	<b>020-018-10</b>
11,5 cm, 4 <sup>1</sup> / <sub>2</sub> "	<b>020-018-11</b>
13,0 cm, 5"	<b>020-018-13</b>
14,5 cm, 5 <sup>3</sup> / <sub>4</sub> "	<b>020-018-14</b>
16,0 cm, 6 <sup>1</sup> / <sub>4</sub> "	<b>020-018-16</b>
18,0 cm, 7"	<b>020-018-18</b>
20,0 cm, 8"	<b>020-018-20</b>
25,0 cm, 10"	<b>020-018-25</b>
30,0 cm, 12"	<b>020-018-30</b>

MOD. USA	
12,0 cm, 4 <sup>3</sup> / <sub>4</sub> "	<b>020-006-10</b>
13,0 cm, 5"	<b>020-006-13</b>
14,5 cm, 5 <sup>3</sup> / <sub>4</sub> "	<b>020-006-14</b>
15,0 cm, 6"	<b>020-006-15</b>
18,0 cm, 7"	<b>020-006-18</b>
20,0 cm, 8"	<b>020-006-20</b>
25,5 cm, 10"	<b>020-006-25</b>
30,0 cm, 12"	<b>020-006-30</b>

MOD. USA	
12,0 cm, 4 <sup>3</sup> / <sub>4</sub> "	<b>020-012-11</b>
13,0 cm, 5"	<b>020-012-13</b>
14,5 cm, 5 <sup>3</sup> / <sub>4</sub> "	<b>020-012-14</b>
15,0 cm, 6"	<b>020-012-15</b>
18,0 cm, 7"	<b>020-012-18</b>
20,0 cm, 8"	<b>020-012-20</b>
25,5 cm, 10"	<b>020-012-25</b>



**ADSON**

12,0 cm, 4<sup>3</sup>/<sub>4</sub>" **020-070-12**  
 15,0 cm, 6" **020-070-15**



**MICRO-ADSON**

12,0 cm, 4<sup>3</sup>/<sub>4</sub>" **020-076-12**  
 15,0 cm, 6" **020-076-15**



**STILLE**

15,0 cm, 6"  
**020-008-15**



**MC INDOE**

15,0 cm, 6"  
**020-158-15**



**TAYLOR**  
 17,5 cm, 6<sup>5</sup>/<sub>8</sub>"  
**020-114-17**



**TAYLOR**  
 17,5 cm, 6<sup>5</sup>/<sub>8</sub>"  
**020-115-17**



**TAYLOR**  
 18,5 cm, 7<sup>1</sup>/<sub>4</sub>"  
**020-117-18**



**GERALD**  
 18,0 cm, 7"  
**020-102-18**



**GERALD**  
18,0 cm, 7"  
020-103-18



**POTTS-SMITH**  
18,0 cm, 7" 020-026-18  
21,0 cm, 8<sup>1</sup>/<sub>4</sub>" 020-026-21  
25,0 cm, 10" 020-026-25



**POTTS-SMITH**  
18,0 cm, 7" 020-027-18  
21,0 cm, 8<sup>1</sup>/<sub>4</sub>" 020-027-21  
25,0 cm, 10" 020-027-25



**SEMKEN**  
12,5 cm, 5" 020-040-12  
15,0 cm, 6" 020-040-15



**CUSHING**  
17,5 cm, 6<sup>5</sup>/<sub>8</sub>"  
020-092-17



**CUSHING**  
17,5 cm, 6<sup>5</sup>/<sub>8</sub>"  
020-093-17



**BROPHY**  
20,0 cm, 8"  
020-094-20

Anatomische Pinzetten  
 Dissecting Forceps  
 Pinzas de disección  
 Pinze anatomiche per dissezione  
 Пинцеты анатомические



**BROPHY**  
 20,0 cm, 8"  
 020-095-20



**BONNEY**  
 18,0 cm, 7"  
 020-120-18



**SINGLE-TUTTLE**  
 23,0 cm, 9"  
 020-516-23



**DENNIS BROWN**  
 20,0 cm, 8"  
 020-126-20



**DUEHRSEN**  
 20,0 cm, 8"  
 020-470-20



**WAUGH**  
 15,0 cm, 6"    020-130-15  
 20,0 cm, 8"    020-130-20



**RAMSEY**  
 18,0 cm, 7"  
 020-136-18



 1 x 2



**STANDARD**

10,5 cm, 4 <sup>1</sup> / <sub>8</sub> "	<b>020-200-10</b>
11,5 cm, 4 <sup>1</sup> / <sub>2</sub> "	<b>020-200-11</b>
13,0 cm, 5"	<b>020-200-13</b>
14,5 cm, 5 <sup>3</sup> / <sub>4</sub> "	<b>020-200-14</b>
15,0 cm, 6"	<b>020-200-15</b>
16,0 cm, 6 <sup>1</sup> / <sub>4</sub> "	<b>020-200-16</b>
18,0 cm, 7"	<b>020-200-18</b>
20,0 cm, 8"	<b>020-200-20</b>
25,0 cm, 10"	<b>020-200-25</b>
30,0 cm, 12"	<b>020-200-30</b>

 2 x 3



11,5 cm, 4 <sup>1</sup> / <sub>2</sub> "	<b>020-252-11</b>
13,0 cm, 5"	<b>020-252-13</b>
14,5 cm, 5 <sup>3</sup> / <sub>4</sub> "	<b>020-252-14</b>
16,0 cm, 6 <sup>1</sup> / <sub>4</sub> "	<b>020-252-16</b>
18,0 cm, 7"	<b>020-252-18</b>
20,0 cm, 8"	<b>020-252-20</b>
25,0 cm, 10"	<b>020-252-25</b>
30,0 cm, 12"	<b>020-252-30</b>

 3 x 4



13,0 cm, 5"	<b>020-254-13</b>
14,5 cm, 5 <sup>3</sup> / <sub>4</sub> "	<b>020-254-14</b>
16,0 cm, 6 <sup>1</sup> / <sub>4</sub> "	<b>020-254-16</b>
18,0 cm, 7"	<b>020-254-18</b>
20,0 cm, 8"	<b>020-254-20</b>

 4 x 5



13,0 cm, 5"	<b>020-256-13</b>
14,5 cm, 5 <sup>3</sup> / <sub>4</sub> "	<b>020-256-14</b>
16,0 cm, 6 <sup>1</sup> / <sub>4</sub> "	<b>020-256-16</b>
18,0 cm, 7"	<b>020-256-18</b>
20,0 cm, 8"	<b>020-256-20</b>

fein  
fine  
finas  
fini

mit Stift  
with pin  
con perno  
con espiga

mit Stift  
with pin  
con perno  
con espiga

englische Modelle  
english patterns  
modelos ingleses  
modelli inglese

1 x 2

1 x 2

1 x 2

1 x 2



13,0 cm, 5"	<b>020-210-13</b>
14,5 cm, 5 <sup>3</sup> / <sub>4</sub> "	<b>020-210-14</b>
15,5 cm, 6"	<b>020-210-15</b>
16,0 cm, 6 <sup>1</sup> / <sub>4</sub> "	<b>020-210-16</b>
18,0 cm, 7"	<b>020-210-18</b>
20,0 cm, 8"	<b>020-210-20</b>
25,0 cm, 10"	<b>020-210-25</b>
30,0 cm, 12"	<b>020-210-30</b>

13,0 cm, 5"	<b>020-218-13</b>
14,5 cm, 5 <sup>3</sup> / <sub>4</sub> "	<b>020-218-14</b>
15,5 cm, 6"	<b>020-218-15</b>
16,0 cm, 6 <sup>1</sup> / <sub>4</sub> "	<b>020-218-16</b>
18,0 cm, 7"	<b>020-218-18</b>
20,0 cm, 8"	<b>020-218-20</b>
25,0 cm, 10"	<b>020-218-25</b>
30,0 cm, 12"	<b>020-218-30</b>

13,0 cm, 5"	<b>020-219-13</b>
14,5 cm, 5 <sup>3</sup> / <sub>4</sub> "	<b>020-219-14</b>
16,0 cm, 6 <sup>1</sup> / <sub>4</sub> "	<b>020-219-16</b>
18,0 cm, 7"	<b>020-219-18</b>
20,0 cm, 8"	<b>020-219-20</b>

13,0 cm, 5"	<b>020-236-13</b>
14,5 cm, 5 <sup>3</sup> / <sub>4</sub> "	<b>020-236-14</b>
15,0 cm, 6"	<b>020-236-15</b>

1 x 2



**MOD. USA**

12,0 cm, 4 <sup>3</sup> / <sub>4</sub> "	<b>020-206-12</b>
13,0 cm, 5"	<b>020-206-13</b>
14,5 cm, 5 <sup>3</sup> / <sub>4</sub> "	<b>020-206-14</b>
15,5 cm, 6"	<b>020-206-15</b>
18,0 cm, 7"	<b>020-206-18</b>
20,0 cm, 8"	<b>020-206-20</b>
25,0 cm, 10"	<b>020-206-25</b>
30,0 cm, 12"	<b>020-206-30</b>

2 x 3



**MOD. USA**

12,0 cm, 4 <sup>3</sup> / <sub>4</sub> "	<b>020-212-12</b>
13,0 cm, 5"	<b>020-212-13</b>
14,5 cm, 5 <sup>3</sup> / <sub>4</sub> "	<b>020-212-14</b>
15,5 cm, 6"	<b>020-212-15</b>
18,0 cm, 7"	<b>020-212-18</b>
20,0 cm, 8"	<b>020-212-20</b>
25,0 cm, 10"	<b>020-212-25</b>
30,0 cm, 12"	<b>020-212-30</b>

1 x 2



**ADSON**

12,0 cm, 4 <sup>3</sup> / <sub>4</sub> "	<b>020-270-12</b>
15,0 cm, 6"	<b>020-270-15</b>

1 x 2



**MICRO-ADSON**

12,0 cm, 4 <sup>3</sup> / <sub>4</sub> "	<b>020-276-12</b>
15,0 cm, 6"	<b>020-276-15</b>

2 x 3



**ADSON**

12,0 cm, 4<sup>3</sup>/<sub>4</sub>" **020-074-12**  
15,0 cm, 6" **020-074-15**

7 x 7



**ADSON-BROWN**

12,0 cm, 4<sup>3</sup>/<sub>4</sub>" **020-288-12**  
15,0 cm, 6" **020-288-15**

1 x 2



**ADSON**

12,0 cm, 4<sup>3</sup>/<sub>4</sub>" **020-282-12**

1 x 2



**STILLE**

15,0 cm, 6" **020-208-15**

2 x 3



**STILLE**

15,0 cm, 6" **020-209-15**

1 x 2



**GILLIES**

15,0 cm, 6" **020-300-15**

2 x 3



**ADLERKREUTZ**

15,0 cm, 6" **020-382-15**  
20,0 cm, 8" **020-382-20**

4 x 5



**ADLERKREUTZ**

15,0 cm, 6" **020-384-15**  
20,0 cm, 8" **020-384-20**

↔ 1 x 2



**SEMKEN**  
12,5 cm, 5" **020-240-12**  
15,5 cm, 6" **020-240-15**

↔ 2 x 3



**SEMKEN**  
12,5 cm, 5" **020-242-12**

↔ 1 x 2



**MC INDOE**  
15,0 cm, 6" **020-358-15**

↔ 1 x 2



**TAYLOR**  
17,5 cm, 6<sup>5</sup>/<sub>8</sub>" **020-314-17**

↔ 1 x 2



**TAYLOR**  
17,5 cm, 6<sup>5</sup>/<sub>8</sub>" **020-315-17**

↔ 1 x 2



**TAYLOR**  
17,5 cm, 6<sup>5</sup>/<sub>8</sub>" **020-317-17**

↔ 1 x 2



**GERALD**  
18,0 cm, 7" **020-302-18**

↔ 1 x 2



**GERALD**  
18,0 cm, 7" **020-303-18**

 1 x 2



**CUSHING**  
17,5 cm, 6<sup>5</sup>/<sub>8</sub>"  
020-292-17

 1 x 2



**CUSHING**  
17,5 cm, 6<sup>5</sup>/<sub>8</sub>"  
020-293-17

 1 x 2



**POTTS-SMITH**  
18,0 cm, 7"      020-226-18  
21,0 cm, 8<sup>1</sup>/<sub>4</sub>"      020-226-21  
25,0 cm, 10"      020-226-25

 1 x 2



**WAUGH**  
15,0 cm, 6"      020-330-15  
20,0 cm, 8"      020-330-20

 1 x 2



**BROPHY**  
20,0 cm, 8"  
020-294-20



**RUSS. MODELL**  
15,0 cm, 6"      020-456-15  
20,0 cm, 8"      020-456-20  
25,0 cm, 10"      020-456-25



**DURANTE**  
14,5 cm, 5<sup>3</sup>/<sub>4</sub>" **020-460-14**  
16,0 cm, 6<sup>1</sup>/<sub>4</sub>" **020-460-16**  
20,0 cm, 8" **020-460-20**



**DUEHRSEN**  
20,0 cm, 8"

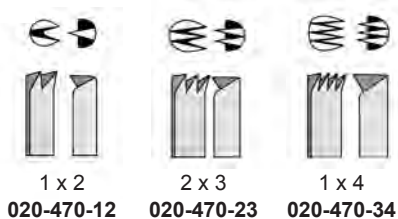

**NELSON**  
15,0 cm, 6" **020-518-15**  
20,0 cm, 8" **020-518-20**  
23,0 cm, 9" **020-518-23**



**DUVAL**  
14,0 cm, 5<sup>1</sup>/<sub>2</sub>"



**COLLIN-DUVAL**  
20,0 cm, 8"

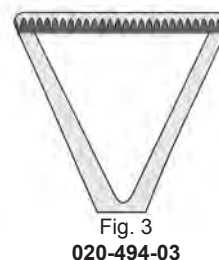

 1 x 2



**LANE**

14,5 cm, 5<sup>3</sup>/<sub>4</sub>" **020-420-14**  
20,0 cm, 8" **020-420-20**

 2 x 3



**LANE**

14,5 cm, 5<sup>3</sup>/<sub>4</sub>" **020-422-14**  
20,0 cm, 8" **020-422-20**



**BROWN**

15,0 cm, 6" **020-410-15**  
20,0 cm, 8" **020-410-20**  
25,0 cm, 10" **020-410-25**



**TREVES**

13,0 cm, 5" **020-510-13**  
15,0 cm, 6" **020-510-15**

 1 x 2



**RAMSEY**

18,0 cm, 7"  
**020-520-18**

 2 x 3



**RAMSEY**

18,0 cm, 7"  
**020-522-18**

 1 x 2



**RAMSEY**

18,0 cm, 7"  
**020-590-18**

 2 x 3



**RAMSEY**

18,0 cm, 7"  
**020-592-18**

mit Stift  
with pin  
con perno  
con espiga

mit Stift  
with pin  
con perno  
con espiga



8,0 cm, 3<sup>1</sup>/<sub>4</sub>" **020-662-08**  
9,0 cm, 3<sup>1</sup>/<sub>2</sub>" **020-662-09**  
10,5 cm, 4<sup>1</sup>/<sub>8</sub>" **020-662-10**  
11,5 cm, 4<sup>1</sup>/<sub>2</sub>" **020-662-11**  
13,0 cm, 5" **020-662-13**  
14,5 cm, 5<sup>1</sup>/<sub>2</sub>" **020-662-14**

8,0 cm, 3<sup>1</sup>/<sub>4</sub>" **020-663-08**  
9,0 cm, 3<sup>1</sup>/<sub>2</sub>" **020-663-09**  
10,5 cm, 4<sup>1</sup>/<sub>8</sub>" **020-663-10**  
11,5 cm, 4<sup>1</sup>/<sub>2</sub>" **020-663-11**  
13,0 cm, 5" **020-663-13**  
14,5 cm, 5<sup>1</sup>/<sub>2</sub>" **020-663-14**

8,0 cm, 3<sup>1</sup>/<sub>4</sub>" **020-666-08**  
9,0 cm, 3<sup>1</sup>/<sub>2</sub>" **020-666-09**  
10,5 cm, 4<sup>1</sup>/<sub>8</sub>" **020-666-10**  
11,5 cm, 4<sup>1</sup>/<sub>2</sub>" **020-666-11**  
13,0 cm, 5" **020-666-13**  
14,5 cm, 5<sup>1</sup>/<sub>2</sub>" **020-666-14**

8,0 cm, 3<sup>1</sup>/<sub>4</sub>" **020-667-08**  
9,0 cm, 3<sup>1</sup>/<sub>2</sub>" **020-667-09**  
10,5 cm, 4<sup>1</sup>/<sub>8</sub>" **020-667-10**  
11,5 cm, 4<sup>1</sup>/<sub>2</sub>" **020-667-11**  
13,0 cm, 5" **020-667-13**  
14,5 cm, 5<sup>1</sup>/<sub>2</sub>" **020-667-14**

Splitterpinzetten, Mikro-Pinzetten  
 Splinter Forceps, Micro Forceps  
 Pinzas para espinas, Pinzas para microscopia  
 Pinze per schegge, Pinze per microscopia



**HUNTER**  
 10,5 cm, 4<sup>1</sup>/<sub>4</sub>"  
 020-652-10



**HUNTER**  
 10,5 cm, 4<sup>1</sup>/<sub>4</sub>"  
 020-653-10



**WALTER-CARMALT**  
 10,5 cm, 4<sup>1</sup>/<sub>4</sub>"  
 020-656-10



**WALTER-CARMALT**  
 10,5 cm, 4<sup>1</sup>/<sub>4</sub>"  
 020-657-10



**FEILCHENFELD**  
 7,5 cm, 3<sup>1</sup>/<sub>8</sub>" 020-650-07  
 9,0 cm, 3<sup>1</sup>/<sub>2</sub>" 020-650-09  
 11,5 cm, 4<sup>1</sup>/<sub>2</sub>" 020-650-11



10,0 cm, 4"  
 020-806-10



10,0 cm, 4"  
 020-807-10



**GRAEFE**  
10,0 cm, 4"  
020-810-10



**GRAEFE**  
10,0 cm, 4"  
020-811-10



**GRAEFE**  
10,0 cm, 4"  
020-813-10

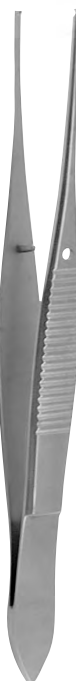

**GRAEFE**  
10,0 cm, 4"  
020-814-10



**GRAEFE**  
10,0 cm, 4"  
020-815-10



**GRAEFE**  
10,0 cm, 4"  
020-817-10



Fig. 3  
 11,5 cm, 4 1/2"  
 020-601-03

0,3 mm x 45°



Fig. 4  
 11,5 cm, 4 1/2"  
 020-601-04

0,3 mm x 90°



Fig. 5  
 11,5 cm, 4 1/2"  
 020-601-05

0,3 mm



Fig. 7  
 11,5 cm, 4 1/2"  
 020-601-07

0,3 mm x 45°



11,0 cm, 4 3/8"  
 020-620-01

9 mm



11,0 cm, 4 3/8"  
 020-620-02

9 mm



11,0 cm, 4 3/8"  
 020-620-03

9 mm



11,0 cm, 4 3/8"  
 020-620-04

9 mm

diamantbeschichtet  
 diamond coated  
 diamantado  
 diamantato



DE BAKEY

1,5 mm      2,0 mm      2,4 mm      2,8 mm



16,0 cm, 6 <sup>1</sup> / <sub>4</sub> "	<b>020-700-16</b>	<b>020-702-16</b>	<b>020-704-16</b>	<b>020-706-16</b>
20,0 cm, 8"	<b>020-700-20</b>	<b>020-702-20</b>	<b>020-704-20</b>	<b>020-706-20</b>
24,0 cm, 9 <sup>1</sup> / <sub>2</sub> "	<b>020-700-24</b>	<b>020-702-24</b>	<b>020-704-24</b>	<b>020-706-24</b>
30,0 cm, 12"	<b>020-700-30</b>	<b>020-702-30</b>	<b>020-704-30</b>	<b>020-706-30</b>

2,8 mm      3,5 mm      3,5 mm



16,0 cm, 6 <sup>1</sup> / <sub>4</sub> "	<b>020-716-16</b>	<b>020-708-16</b>	<b>020-718-16</b>
20,0 cm, 8"	<b>020-716-20</b>	<b>020-708-20</b>	<b>020-718-20</b>
24,0 cm, 9 <sup>1</sup> / <sub>2</sub> "	<b>020-716-24</b>	<b>020-708-24</b>	<b>020-718-24</b>
30,0 cm, 12"	<b>020-716-30</b>	<b>020-708-30</b>	<b>020-718-30</b>



DE BAKEY

1,5 mm      2,0 mm



16,0 cm, 6 <sup>1</sup> / <sub>4</sub> "	<b>020-701-16</b>	<b>020-703-16</b>
20,0 cm, 8"	<b>020-701-20</b>	<b>020-703-20</b>
24,0 cm, 9 <sup>1</sup> / <sub>2</sub> "	<b>020-701-24</b>	<b>020-703-24</b>
30,0 cm, 12"	<b>020-701-30</b>	<b>020-703-30</b>

Pinzette mit Hartmetalleinlagen  
 Forceps with tungsten carbide inserts  
 Pinzas con bocas de carburo tungsteno  
 Pinze con morsi in carburo di tungsteno



**STANDARD**

14,5 cm, 5 <sup>3</sup> / <sub>4</sub> "	<b>021-200-14</b>
16,0 cm, 6 <sup>1</sup> / <sub>4</sub> "	<b>021-200-16</b>
18,0 cm, 7"	<b>021-200-18</b>
20,0 cm, 8"	<b>021-200-20</b>
25,0 cm, 10"	<b>021-200-25</b>
30,0 cm, 12"	<b>021-200-30</b>

**STANDARD**

14,0 cm, 5 <sup>1</sup> / <sub>2</sub> "	<b>021-208-14</b>
16,0 cm, 6 <sup>1</sup> / <sub>4</sub> "	<b>021-208-16</b>
18,0 cm, 7"	<b>021-208-18</b>
20,0 cm, 8"	<b>021-208-20</b>
25,0 cm, 10"	<b>021-208-25</b>
30,0 cm, 12"	<b>021-208-30</b>

**STANDARD**

12,5 cm, 5"	<b>021-040-12</b>
15,0 cm, 6"	<b>021-040-15</b>

**STANDARD**

15,0 cm, 6"	<b>021-140-15</b>
23,0 cm, 9"	<b>021-140-23</b>
25,0 cm, 10"	<b>021-140-25</b>



**GILLIES**  
 15,0 cm, 6"  
 021-300-15



**MC INDOE**  
 15,0 cm, 6"  
 021-158-15



**GERALD**  
 17,0 cm, 6<sup>3</sup>/<sub>4</sub>"

021-102-17



021-302-17



**POTTS-SMITH**  
 15,0 cm, 6" 021-026-15  
 18,0 cm, 7" 021-026-18  
 20,0 cm, 8" 021-026-20



**BONNEY**  
 17,5 cm, 6<sup>5</sup>/<sub>8</sub>"  
 021-590-17



**CUSHING**  
 17,5 cm, 6<sup>5</sup>/<sub>8</sub>"



021-092-17



021-093-17



**CUSHING-TAYLOR**  
 18,0 cm, 7"  
 021-117-18



**ADSON**  
 17,5 cm, 6<sup>5</sup>/<sub>8</sub>"

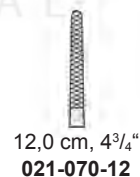

12,0 cm, 4<sup>3</sup>/<sub>4</sub>"  
 021-070-12

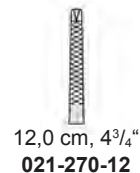

12,0 cm, 4<sup>3</sup>/<sub>4</sub>"  
 021-270-12

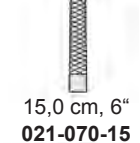

15,0 cm, 6"  
 021-070-15



15,0 cm, 6"  
 021-270-15

**Tuch-, Schlauchklemmen, Tupferzangen**

**Towel Clamps, Sponge and Dressing Forceps, Tubing Clamps**

**Pinzas de campo, Pinzas para vendajes y torundas y para tubos**

**Pinze per fissare le compresse, per medicatura e tamponi, e per tubi**

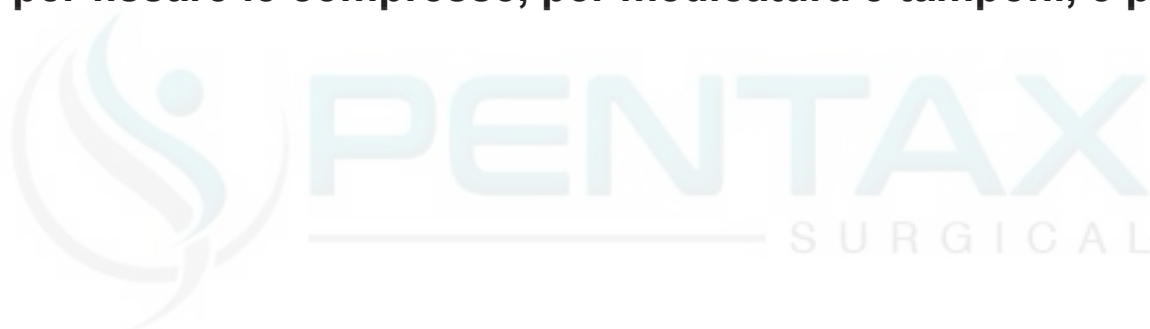



**SCHAEDEL**  
9,0 cm, 3 1/2"  
030-101-09



**ENGL. MODELL**  
9,0 cm, 3 1/2"  
030-109-09



**JONES**  
5,0 cm, 2" **030-105-05**  
7,0 cm, 2 3/4" **030-105-07**  
9,0 cm, 3 1/2" **030-105-09**



**JONES**  
9,0 cm, 3 1/2"  
030-107-09

mit Schlauch- oder Kabelhalter  
with clip for tubing or cable  
con porta-tubo o porta-cable  
con porta-tubo o porta-cavo



**BACKHAUS**  
9,0 cm, 3 1/2" **030-000-09**  
11,0 cm, 4 3/8" **030-000-11**  
13,0 cm, 5" **030-000-13**  
15,0 cm, 6" **030-000-15**



11,0 cm, 4 3/8"  
**030-005-11**



**ROEDER**  
13,0 cm, 5"  
**030-010-13**



**ROEDER**  
15,0 cm, 5"  
030-010-15



**BERNHARD**  
16,5 cm, 6½"  
030-044-16



Kugel / Pfanne  
Ball / Socket  
Bola / Cojinete  
Palla / Cuscinetto

13,0 cm, 5"  
030-024-13

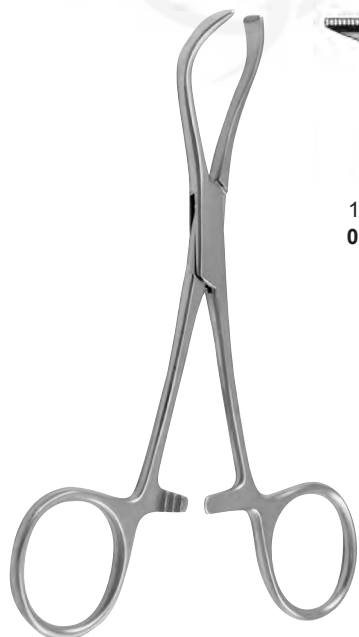

**LORNA**



10,0 cm, 4"  
030-014-10



13,0 cm, 5"  
030-014-13



**LANE**

15,0 cm, 6"	030-040-15
18,0 cm, 7"	030-040-18
20,0 cm, 8"	030-040-20

Tuchklemmen, Korn- und Tupferzangen  
 Towel Clamps, Sponge and Dressing Forceps  
 Pinzas de campo, Pinzas para vendajes y torundas  
 Pinze per fissare le compresse, Pinze per medicatura e tamponi



**TOHOKU**



10,0 cm, 4"  
 030-020-10



13,0 cm, 5"  
 030-020-13



**PEERS**  
 14,5 cm, 5<sup>3</sup>/<sub>4</sub>"  
 030-030-14



**LISTER**  
 13,0 cm, 5"    030-360-13  
 16,0 cm, 6<sup>1</sup>/<sub>4</sub>"    030-360-16  
 18,0 cm, 7"    030-360-18



**BRYANT**  
 13,0 cm, 5"  
 030-351-13



**BOZEMANN**  
 26,0 cm, 10<sup>1</sup>/<sub>4</sub>"  
 030-320-26



**BOZEMANN**  
26,0 cm, 10<sup>1</sup>/<sub>4</sub>"  
030-321-26



**COLLIN**  
25,0 cm, 9<sup>3</sup>/<sub>4</sub>"  
030-300-25



**CHERON**  
25,0 cm, 9<sup>3</sup>/<sub>4</sub>"  
030-303-25



**PELKMANN**  
25,0 cm, 9<sup>3</sup>/<sub>4</sub>"

030-310-25

030-311-25



**ULRICH**

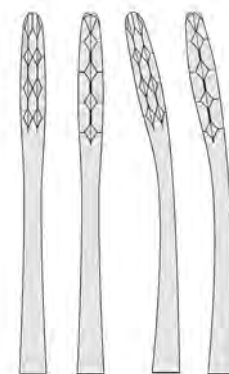

22,0 cm, 8<sup>5</sup>/<sub>8</sub>" 030-200-22 030-201-22  
25,0 cm, 9<sup>3</sup>/<sub>4</sub>" 030-200-25 030-201-25  
27,0 cm, 10<sup>5</sup>/<sub>8</sub>" 030-200-27 030-201-27

Korn- und Tupferzangen  
 Sponge and Dressing Forceps  
 Pinzas para vendajes y torundas  
 Pinze per medicatura e tamponi

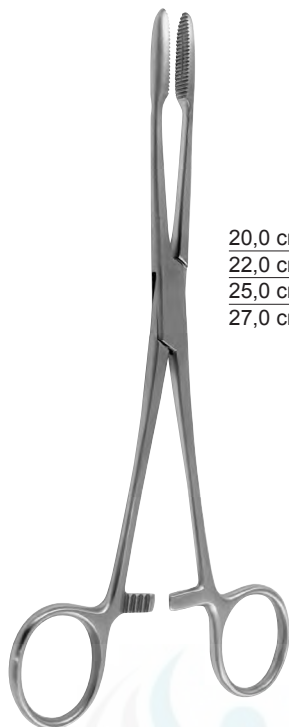

GROSS-MAIER

20,0 cm, 8"	030-210-20	030-211-20
22,0 cm, 8 <sup>5</sup> / <sub>8</sub> "	030-210-22	030-211-22
25,0 cm, 9 <sup>3</sup> / <sub>4</sub> "	030-210-25	030-211-25
27,0 cm, 10 <sup>5</sup> / <sub>8</sub> "	030-210-27	030-211-27

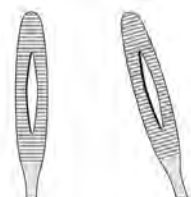

FOERSTER

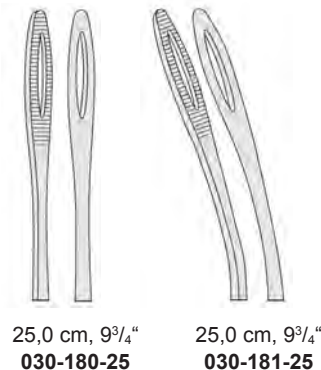

25,0 cm, 9 <sup>3</sup> / <sub>4</sub> "	030-180-25
25,0 cm, 9 <sup>3</sup> / <sub>4</sub> "	030-181-25



FOERSTER-BALLENGER

18,0 cm, 7"	030-160-18	030-161-18	030-170-18	030-171-18
20,0 cm, 8"	030-160-20	030-161-20	030-170-20	030-171-20
25,0 cm, 9 <sup>3</sup> / <sub>4</sub> "	030-160-25	030-161-25	030-170-25	030-171-25

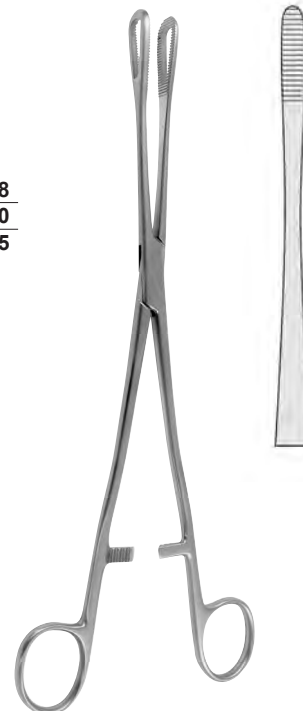
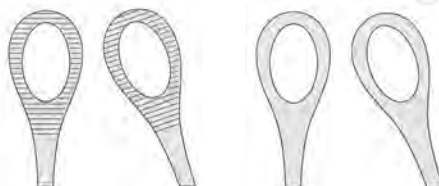

RAMPLEY

18,0 cm, 7"	030-190-18
25,0 cm, 9 <sup>3</sup> / <sub>4</sub> "	030-190-25



**PRESBYTERIAN**  
16,5 cm, 6½" **032-012-16**  
18,0 cm, 7" **032-012-18**  
20,0 cm, 8" **032-012-20**



**BERLIN**  
14,5 cm, 5¾" **032-006-14**



15,0 cm, 6" **032-002-15**

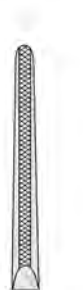

18,0 cm, 7" **032-002-18**



20,0 cm, 8" **032-002-20**



15,0 cm, 6" **032-004-15**



18,0 cm, 7" **032-004-18**



20,0 cm, 8" **032-004-20**



**Klemmen**  
**Forceps**  
**Pinas**  
**Pinze**

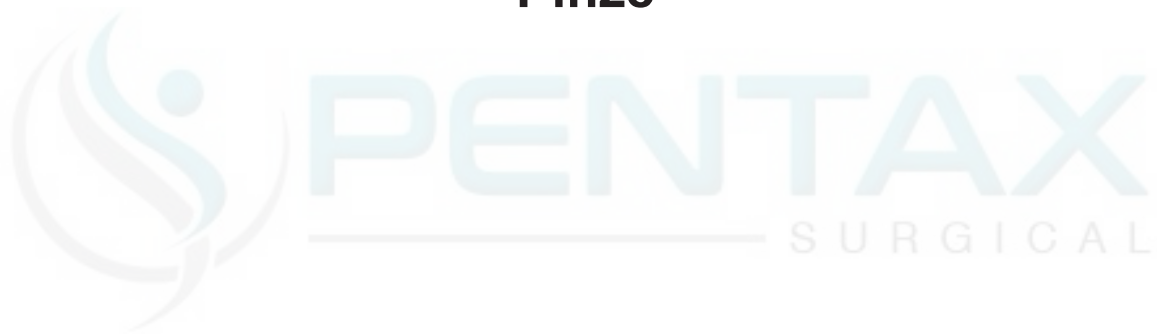

Bulldogklemmen  
 Bulldog Clamps  
 Clamps Bulldog  
 Pinze Bulldog



3,5 cm, 1 1/2"	026-014-03	026-015-03
5,0 cm, 2"	026-014-05	026-015-05



HESS  
026-520-01



HESS  
026-520-02

DIEFFENBACH



3,8 cm, 1 1/2"	026-018-04	026-019-04
5,0 cm, 2"	026-018-05	026-019-05
6,3 cm, 2 1/2"	026-018-06	026-019-06
7,6 cm, 3"	026-018-07	026-019-07
9,0 cm, 3 1/2"	026-018-09	026-019-09

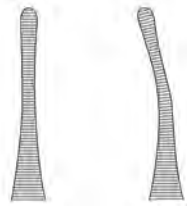

JOHNS-HOPKINS



JOHNS-HOPKINS  
23,0 cm, 9"  
026-295-23



mit atraumatischer Riefung  
with non-traumatic serration  
con bocas atraumáticas  
con presa atraumatica  
с атравматичной зазубреностью

		L
7,5 cm, 3"	<b>026-292-07</b>	2,5 cm, 1"
8,5 cm, 3 <sup>1</sup> / <sub>4</sub> "	<b>026-292-08</b>	3,5 cm, 1 <sup>3</sup> / <sub>8</sub> "
10,5 cm, 4 <sup>1</sup> / <sub>8</sub> "	<b>026-292-10</b>	5,0 cm, 2"
12,0 cm, 4 <sup>3</sup> / <sub>4</sub> "	<b>026-292-12</b>	6,8 cm, 2 <sup>3</sup> / <sub>4</sub> "

DE BAKEY

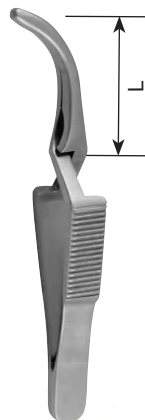

mit atraumatischer Riefung  
with non-traumatic serration  
con bocas atraumáticas  
con presa atraumatica  
с атравматичной зазубреностью

		L
7,0 cm, 2 <sup>3</sup> / <sub>4</sub> "	<b>026-293-07</b>	2,5 cm, 1"
8,0 cm, 3 <sup>1</sup> / <sub>8</sub> "	<b>026-293-08</b>	3,5 cm, 1 <sup>3</sup> / <sub>8</sub> "
10,0 cm, 3 <sup>3</sup> / <sub>4</sub> "	<b>026-293-10</b>	5,0 cm, 2"
11,5 cm, 4 <sup>1</sup> / <sub>2</sub> "	<b>026-293-12</b>	6,8 cm, 2 <sup>3</sup> / <sub>4</sub> "

DE BAKEY



**TITANIUM**  
3,5 cm, 1<sup>3</sup>/<sub>8</sub>"  
vena **027-032-35**  
arteria **027-042-35**



**TITANIUM**  
3,5 cm, 1<sup>3</sup>/<sub>8</sub>"  
vena **027-033-35**  
arteria **027-043-35**



gerade  
straight  
recto  
retto

**TITANIUM**  
4,0 cm, 1<sup>5</sup>/<sub>8</sub>"  
vena **027-032-40**  
arteria **027-042-40**



gebogen  
curved  
curvo  
curvo

**TITANIUM**  
4,0 cm, 1<sup>5</sup>/<sub>8</sub>"  
vena **027-033-40**  
arteria **027-043-40**

Bulldogklemmen, Darm- und Gewebefäßzangen  
 Bulldog Clamps, Intestinal and Tissue Grasping Forceps  
 Clamps Bulldog, Pinzas intestinales y para tejidos  
 Pinze Bulldog, Pinze da presa per intestino e tessuti

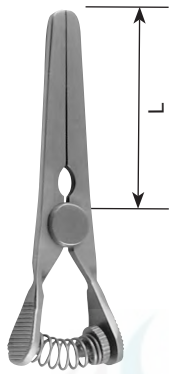

GLOVER

		L
6,8 cm, 2 <sup>3</sup> / <sub>4</sub> "	<b>026-298-07</b>	3,3 cm, 1 <sup>3</sup> / <sub>8</sub> "
9,6 cm, 3 <sup>3</sup> / <sub>4</sub> "	<b>026-298-09</b>	5,0 cm, 2"
11,7 cm, 4 <sup>3</sup> / <sub>4</sub> "	<b>026-298-11</b>	6,9 cm, 2 <sup>3</sup> / <sub>4</sub> "

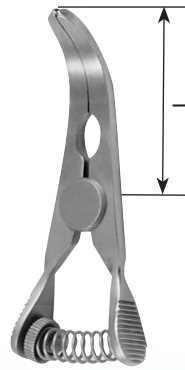

GLOVER

		L
6,5 cm, 2 <sup>1</sup> / <sub>2</sub> "	<b>026-299-06</b>	3,3 cm, 1 <sup>3</sup> / <sub>8</sub> "
9,1 cm, 3 <sup>1</sup> / <sub>2</sub> "	<b>026-299-09</b>	5,0 cm, 2"
11,0 cm, 4 <sup>3</sup> / <sub>8</sub> "	<b>026-299-11</b>	6,9 cm, 2 <sup>3</sup> / <sub>4</sub> "

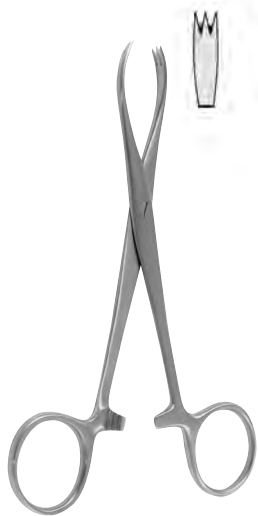

**CHAPUT**  
 13,0 cm, 5"  
 040-370-13



**TUFFIER**  
 13,0 cm, 5"  
 040-372-13



**COLLIN**  
 16,0 cm, 6<sup>1</sup>/<sub>4</sub>"  
 040-376-16



**PENNINGTON**  
15,5 cm, 6" **040-358-15**  
20,0 cm, 8" **040-358-20**



**ATRAUMA**



25,0 cm, 9<sup>3</sup>/<sub>4</sub>"  
**040-658-25**



27,0 cm, 10<sup>1</sup>/<sub>2</sub>"  
**040-658-27**



**MARTEL**  
14,0 cm, 5<sup>1</sup>/<sub>2</sub>"  
**040-364-14**



**WILLET-MARTEL**  
19,0 cm, 7<sup>1</sup>/<sub>2</sub>"  
**040-366-19**

Arterienklemmen  
Haemostatic Forceps  
Pinzas hemostáticas  
Pinze emostatiche



**PRATT**  
15,0 cm, 6"  
040-656-15



**FERGUSSON**

16,0 cm, 6 <sup>1</sup> / <sub>4</sub> "	040-650-16	040-651-16
20,0 cm, 8"	040-650-20	040-651-20

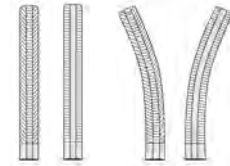

**CARREL**  
10,0 cm, 4"  
040-010-10



**TERRIER**  
10,0 cm, 4"  
040-016-10

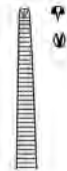

**KROENLEIN**  
13,0 cm, 5"  
040-369-13



PENTAX SURGICAL



**PEAN**

14,0 cm, 5½" **040-368-14**  
16,0 cm, 6¼" **040-368-16**



**BABY-MIXTER**

14,0 cm, 5½"

040-475-01

040-475-02



**SPENCER-WELLS**

13,0 cm, 5"	<b>040-290-13</b>	<b>040-291-13</b>
15,0 cm, 6"	<b>040-290-15</b>	<b>040-291-15</b>
18,0 cm, 7"	<b>040-290-18</b>	<b>040-291-18</b>
20,0 cm, 8"	<b>040-290-20</b>	<b>040-291-20</b>



**HARTMANN**

10,0 cm, 4"

040-000-10

040-001-10

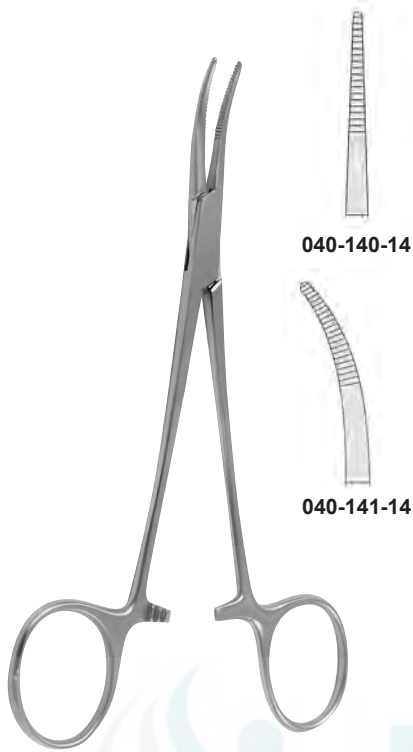

**PROVICENCE-HOSPITAL**  
14,0 cm, 5 1/2"



**HALSTED-MOSQUITO**



14,0 cm, 9 3/4" 040-050-14 040-051-14

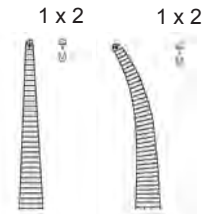

12,5 cm, 5" 040-070-12 040-071-12

14,0 cm, 9 3/4" 040-070-14 040-071-14



**HALSTED-MOSQUITO**



18,0 cm, 7" 040-050-18



18,0 cm, 7" 040-051-18



21,0 cm, 8 1/4" 040-050-21



21,0 cm, 8 1/4" 040-051-21



18,0 cm, 7" 040-070-18



18,0 cm, 7" 040-071-18



21,0 cm, 8 1/4" 040-070-21



21,0 cm, 8 1/4" 040-071-21



**MICRO-MOSQUITO**

			1 x 2	1 x 2
10,0 cm, 4"	<b>040-020-10</b>	<b>040-021-10</b>	<b>040-030-10</b>	<b>040-031-10</b>
12,0 cm, 4 <sup>3</sup> / <sub>4</sub> "	<b>040-020-12</b>	<b>040-021-12</b>	<b>040-030-12</b>	<b>040-031-12</b>



**KELLY**  
14,0 cm, 5<sup>1</sup>/<sub>2</sub>"



**KELLY-RANKIN**  
16,0 cm, 6<sup>1</sup>/<sub>4</sub>"

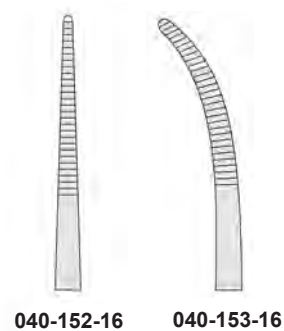

Arterienklemmen  
 Haemostatic Forceps  
 Pinzas hemostáticas  
 Pinze emostatiche



**LERICHE**  
 15,0 cm, 6"



**BABY-OVERHOLT**  
 13,5 cm, 5 1/4"  
 040-424-14



**DANDY**  
 14,0 cm, 5 1/2"



**CRILE**  
 14,0 cm, 5 1/2"





**DIXON-LOVELACE**  
15,0 cm, 6"

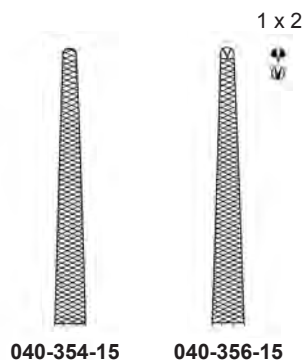

040-354-15      040-356-15



**BIRKETT**  
19,0 cm, 7 1/2"

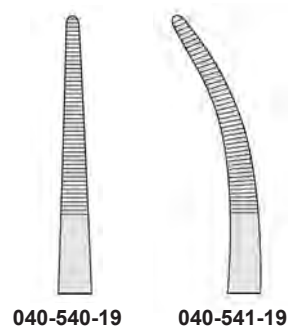

040-540-19      040-541-19



**CRILE-RANKIN**  
16,0 cm, 6 1/4"

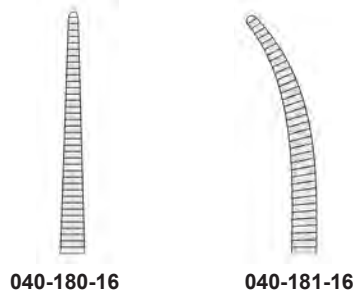

040-180-16      040-181-16

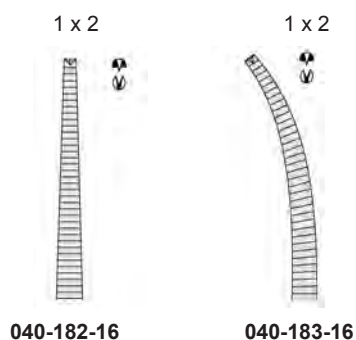

040-182-16      040-183-16

Arterienklemmen  
 Haemostatic Forceps  
 Pinzas hemostáticas  
 Pinze emostatiche

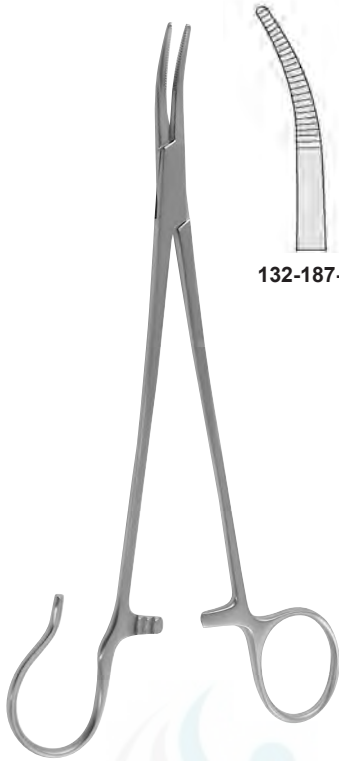

**SCHNIDT**  
 19,0 cm, 7½"

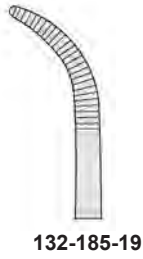

**SCHNIDT-SAWTELL**  
 19,0 cm, 7½"

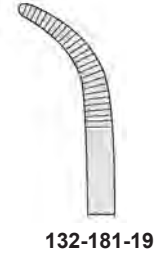

**ADSON**  
 18,5 cm, 7¼"

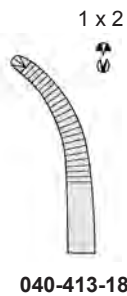
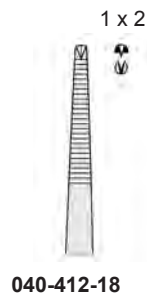

**CRAFOORD**  
 24,0 cm, 9½"  
 040-453-24



15,0 cm, 6"	<b>040-480-15</b>	<b>040-481-15</b>
18,5 cm, 7 1/4"	<b>040-480-18</b>	<b>040-481-18</b>

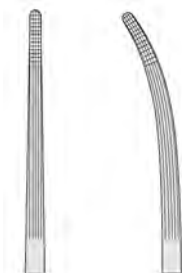

16,0 cm, 6 1/4"	<b>040-340-16</b>	<b>040-341-16</b>
20,0 cm, 8"	<b>040-340-20</b>	<b>040-341-20</b>

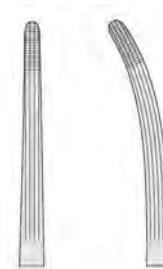

**BAINBRIDGE**

**ROCHESTER-CARMALT**



13,0 cm, 5"	<b>040-262-13</b>	<b>040-263-13</b>
14,0 cm, 5 1/2"	<b>040-262-14</b>	<b>040-263-14</b>
16,0 cm, 6 1/4"	<b>040-262-16</b>	<b>040-263-16</b>

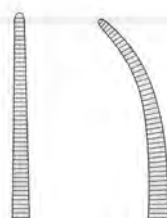

**PEAN DELICATE**



13,0 cm, 5"	<b>040-352-13</b>	<b>040-353-13</b>
14,0 cm, 5 1/2"	<b>040-352-14</b>	<b>040-353-14</b>
16,0 cm, 6 1/4"	<b>040-352-16</b>	<b>040-353-16</b>

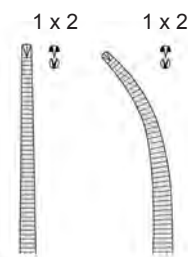

**KOCHER DELICATE**



ROCHESTER-PEAN

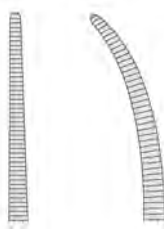

14,0 cm, 5½"	040-260-14	040-261-14
16,0 cm, 6¼"	040-260-16	040-261-16
18,0 cm, 7"	040-260-18	040-261-18
20,0 cm, 8"	040-260-20	040-261-20
22,0 cm, 8⅝"	040-260-22	040-261-22
24,0 cm, 9½"	040-260-24	040-261-24
26,0 cm, 10¼"	040-260-26	040-261-26
30,0 cm, 12"	040-260-30	040-261-30

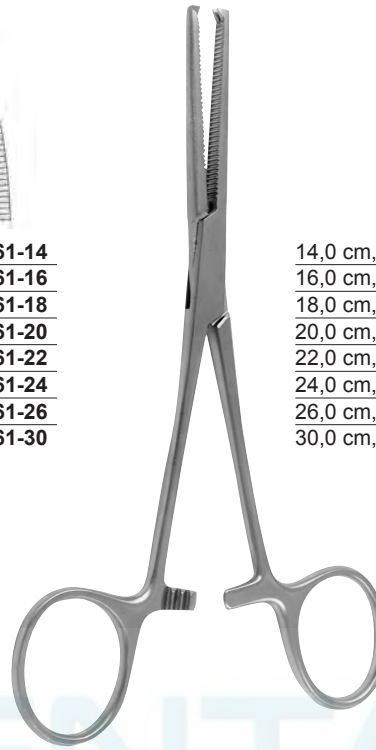

KOCHER-OCHSNER

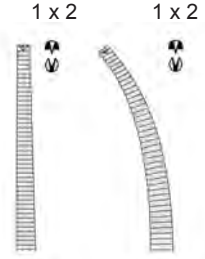

14,0 cm, 5½"	040-350-14	040-351-14
16,0 cm, 6¼"	040-350-16	040-351-16
18,0 cm, 7"	040-350-18	040-351-18
20,0 cm, 8"	040-350-20	040-351-20
22,0 cm, 8⅝"	040-350-22	040-351-22
24,0 cm, 9½"	040-350-24	040-351-24
26,0 cm, 10¼"	040-350-26	040-351-26
30,0 cm, 12"	040-350-30	040-351-30



BENGOLEA

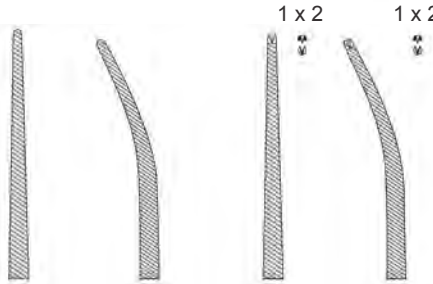

20,0 cm, 8"	040-384-20	040-385-20	040-386-20	040-387-20
26,0 cm, 10¼"	040-384-26	040-385-26	040-386-26	040-387-26



**HEISS**  
20,0 cm, 8"

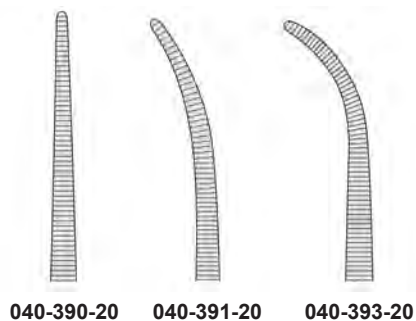

040-390-20 040-391-20 040-393-20



**ROBERTS**  
22,0 cm, 8<sup>5</sup>/<sub>8</sub>"

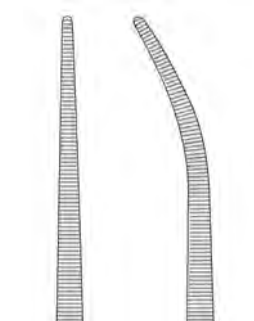

040-448-22 040-449-22



**SAROT**  
24,0 cm, 9<sup>1</sup>/<sub>2</sub>"

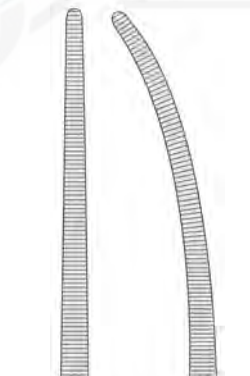

040-450-24 040-451-24



**NEGUS**  
19,0 cm, 7<sup>1</sup>/<sub>2</sub>"

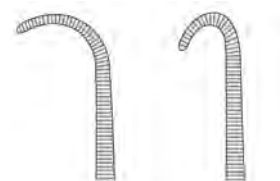

040-533-01 040-533-02



14,0 cm, 5½"  
040-411-14    18,0 cm, 7"  
040-411-18

**BABY-ADSON**



**MICRO-ADSON**  
14,0 cm, 5½"  
040-409-14



**BABY-MIXTER**  
18,0 cm, 7"  
040-475-18



**OVERHOLT-MIXTER**  
21,0 cm, 8¼"  
040-471-21



**JOHNS HOPKINS**  
20,0 cm, 8"  
040-497-20



**OVERHOLT**

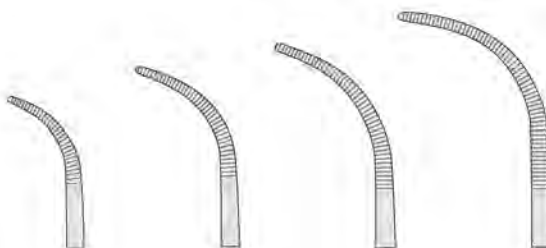

18,5 cm, 7<sup>1</sup>/<sub>4</sub>"  
040-423-01

20,0 cm, 8"  
040-423-02

21,0 cm, 8<sup>1</sup>/<sub>4</sub>"  
040-423-03

21,5 cm, 8<sup>1</sup>/<sub>2</sub>"  
040-423-04



**RUMEL**  
23,0 cm, 9"



040-441-01

040-441-02

040-441-03

040-441-04

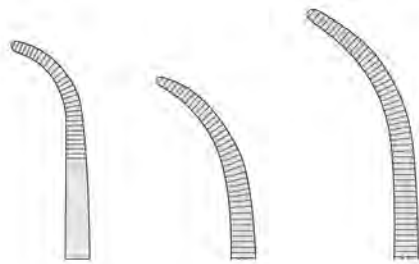

**040-421-01** 20,5 cm, 7<sup>3</sup>/<sub>4</sub>"  
**040-421-02** 20,0 cm, 7<sup>1</sup>/<sub>2</sub>"  
**040-421-03** 21,5 cm, 8<sup>1</sup>/<sub>4</sub>"

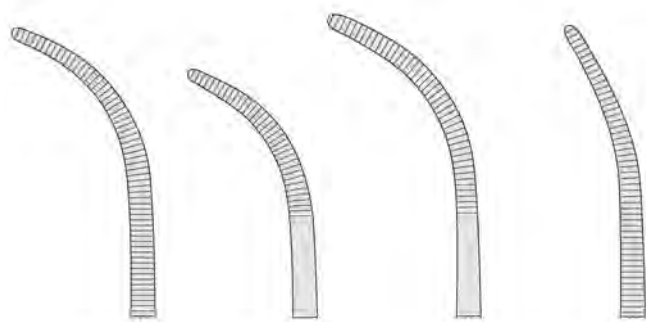

**040-421-04** 22,0 cm, 8<sup>3</sup>/<sub>4</sub>"  
**040-421-05** 21,5 cm, 8<sup>1</sup>/<sub>2</sub>"  
**040-421-06** 22,0 cm, 8<sup>3</sup>/<sub>4</sub>"  
**040-421-07** 22,0 cm, 8<sup>3</sup>/<sub>4</sub>"

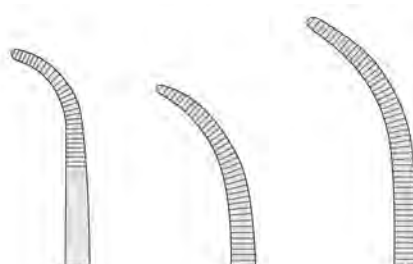

**040-422-01** 27,0 cm, 10<sup>3</sup>/<sub>4</sub>"  
**040-422-02** 26,0 cm, 10<sup>1</sup>/<sub>4</sub>"  
**040-422-03** 27,0 cm, 10<sup>3</sup>/<sub>4</sub>"

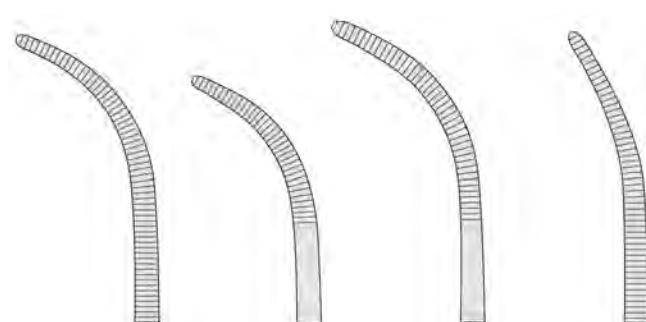

**040-422-04** 27,5 cm, 10<sup>3</sup>/<sub>4</sub>"  
**040-422-05** 27,5 cm, 10<sup>3</sup>/<sub>4</sub>"  
**040-422-06** 28,0 cm, 11"  
**040-422-07** 28,0 cm, 11"



**OVERHOLT-GEISSENDOERFER**



TOENNIS

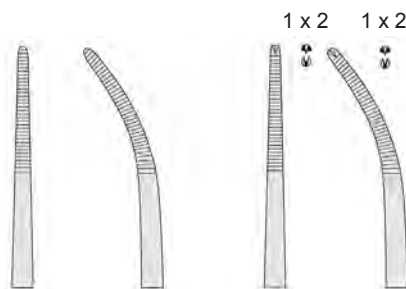

21,0 cm, 8 <sup>1</sup> / <sub>4</sub> "	040-442-21	040-443-21	040-444-21	040-445-21
26,0 cm, 10 <sup>1</sup> / <sub>4</sub> "	040-442-26	040-443-26	040-444-26	040-445-26



KELLY

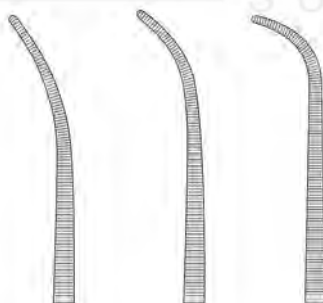

19,0 cm, 7 <sup>1</sup> / <sub>2</sub> "	040-463-19	040-465-19	040-467-19
22,0 cm, 8 <sup>5</sup> / <sub>8</sub> "	040-463-22	040-465-22	040-467-22
24,0 cm, 9 <sup>1</sup> / <sub>2</sub> "	040-463-24	040-465-24	040-467-24



18,0 cm, 7"	<b>040-429-18</b>
22,0 cm, 8 <sup>5</sup> / <sub>8</sub> "	<b>040-429-22</b>
25,0 cm, 9 <sup>3</sup> / <sub>4</sub> "	<b>040-429-25</b>
28,0 cm, 11"	<b>040-429-28</b>

**MINI-GEMINI**



14,0 cm, 5 <sup>1</sup> / <sub>2</sub> "	<b>040-431-14</b>
16,0 cm, 6 <sup>1</sup> / <sub>4</sub> "	<b>040-431-16</b>
18,0 cm, 7"	<b>040-431-18</b>
20,0 cm, 8"	<b>040-431-20</b>
23,0 cm, 9"	<b>040-431-23</b>
25,0 cm, 9 <sup>3</sup> / <sub>4</sub> "	<b>040-431-25</b>
28,0 cm, 11"	<b>040-431-28</b>

**GEMINI**

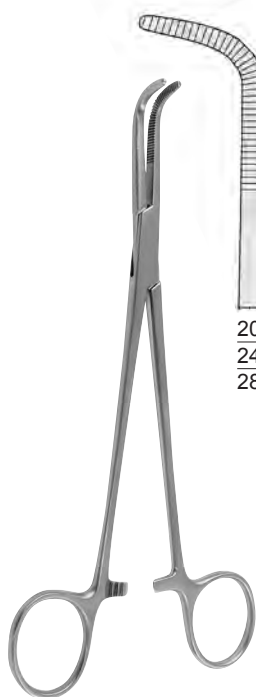

20,0 cm, 8"	<b>040-433-20</b>
24,0 cm, 9 <sup>1</sup> / <sub>2</sub> "	<b>040-433-24</b>
28,0 cm, 11"	<b>040-433-28</b>

**KANTROWITZ**



19,0 cm, 7 <sup>1</sup> / <sub>2</sub> "	<b>040-543-19</b>
21,0 cm, 8 <sup>1</sup> / <sub>4</sub> "	<b>040-543-21</b>
24,0 cm, 9 <sup>1</sup> / <sub>2</sub> "	<b>040-543-24</b>

**WIKSTROEM**



**MIXTER**  
15,5 cm, 6" **040-461-15**  
19,0 cm, 7½" **040-461-19**



**MIXTER-O'SHAUGNESSY**  
15,5 cm, 6" **040-477-15**  
19,0 cm, 7½" **040-477-19**



**MIXTER**  
22,0 cm, 8¾" **040-473-22**



**MIXTER**  
23,0 cm, 9" **040-473-23**

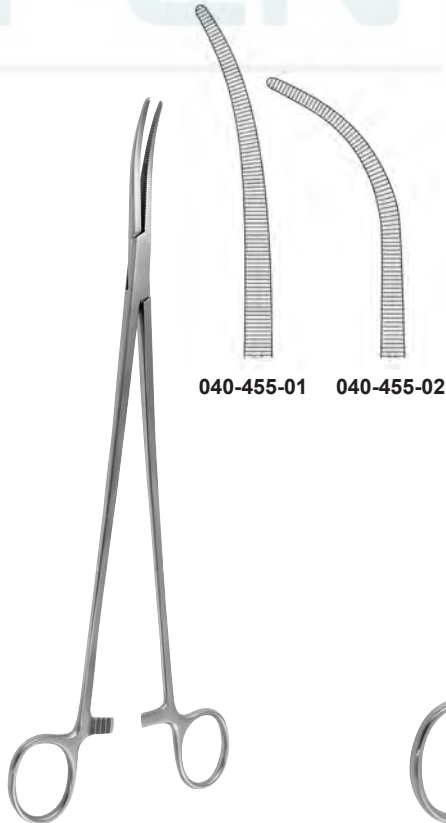

**ZENKER**

040-455-01 040-455-02



**ZENKER**

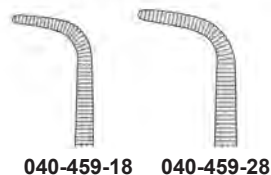

040-459-18 040-459-28

Präparier- und Ligaturklemmen  
 Dissecting and Ligature Forceps  
 Pinzas de disección y ligaduras  
 Pinze per preparazioni e legature



**LAWRENCE**  
 27,5 cm, 10<sup>3</sup>/<sub>4</sub>"  
 040-457-28



**HOSEMANN**  
 21,0 cm, 8<sup>1</sup>/<sub>4</sub>"

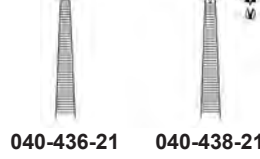

**DESJARDINS**  
 21,0 cm, 8<sup>1</sup>/<sub>4</sub>"  
 040-529-21



**MIXTER**  
 22,0 cm, 8<sup>3</sup>/<sub>4</sub>" 040-479-22  
 25,0 cm, 9<sup>3</sup>/<sub>4</sub>" 040-479-25  
 28,0 cm, 11" 040-479-28



**LAHEY**  
 19,0 cm, 7<sup>1</sup>/<sub>2</sub>" 040-501-19  
 23,0 cm, 9" 040-501-23



**LOWER**  
 18,0 cm, 7"  
 040-503-18



**MC QUIGG-MIXTER**  
22,0 cm, 8<sup>3</sup>/<sub>4</sub>"  
040-507-22



**GRAY**

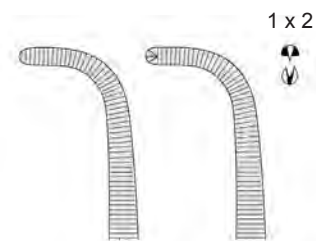

22,0 cm, 8<sup>3</sup>/<sub>4</sub>" 040-523-22 040-525-22  
23,0 cm, 9" 040-523-23 040-525-23



**CRAFOORD-SELLORS**



22,0 cm, 8<sup>3</sup>/<sub>4</sub>" 040-456-22  
23,0 cm, 9" 040-456-23  
24,0 cm, 9<sup>1</sup>/<sub>2</sub>" 040-456-24



**FINOCCHIETTO**  
24,0 cm, 9<sup>1</sup>/<sub>2</sub>"  
040-505-24

Gallenkanal- und Nierenstielklemmen  
 Gall Duct and Kidney Pedicle Clamps  
 Pinzas-clamps para pedúnculo renal  
 Pinze per peduncoli renali



**GUYON**  
 20,0 cm, 8" **040-509-20**  
 22,0 cm, 8<sup>3</sup>/<sub>4</sub>" **040-509-22**  
 24,0 cm, 9<sup>1</sup>/<sub>2</sub>" **040-509-24**



**GUYON**  
 23,0 cm, 9" **040-513-23**

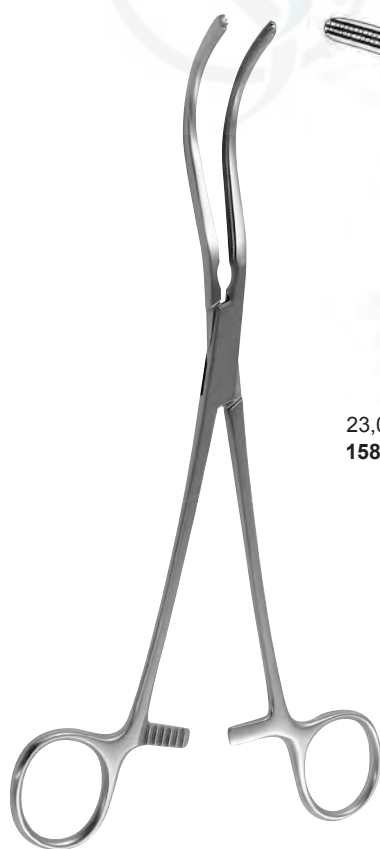

**GUYON**

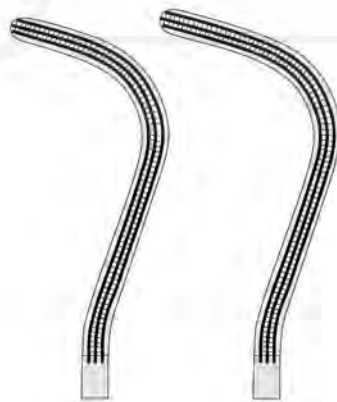

23,0 cm, 9"  
**158-519-23**

24,0 cm, 9<sup>1</sup>/<sub>2</sub>"  
**158-519-24**



**STILLE**  
 23,0 cm, 9"  
**040-511-23**



**HERRICK**  
23,0 cm, 9"  
040-517-23



**URO-TANGENTIAL**



23,0 cm, 9"  
170-055-01

24,0 cm, 9½"  
170-055-02



**LOVELACE**  
20,0 cm, 8"  
141-004-20

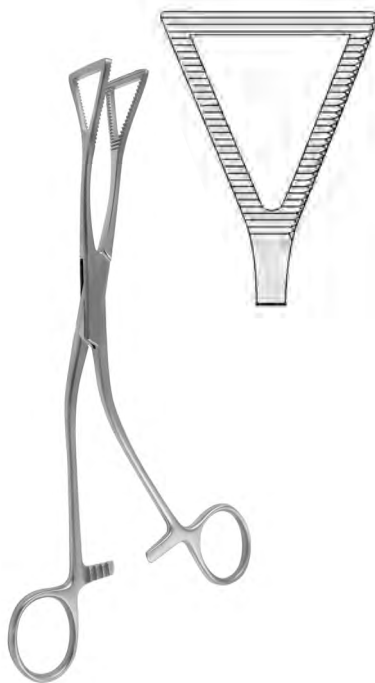

**LOVELACE**  
20,0 cm, 8"  
141-005-20



**PRICE-THOMAS**  
22,0 cm, 8¾"  
141-001-22

Bronchusklemmen, Peritoneumklemmen, Hysterektomieklemme  
 Bronchus Forceps, Peritoneum Forceps, Hysterectomy Forceps  
 Pinzas-clamps para bronquios, Pinzas-clamps para peritoneo y  
 Pinze per legature, Pinze per peritoneo e per isterectomia



**PRICE-THOMAS**  
 22,0 cm, 8<sup>3</sup>/<sub>4</sub>"



141-002-01



141-002-02



**SEMB**  
 24,0 cm, 9<sup>1</sup>/<sub>2</sub>"

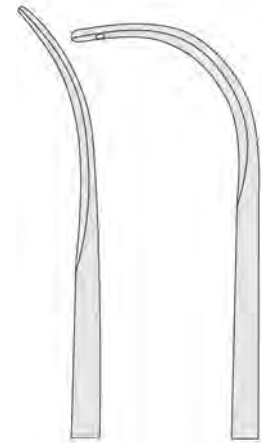

141-003-01

141-003-02



**BABY-MIKULICZ**  
 14,0 cm, 5<sup>1</sup>/<sub>2</sub>"  
 040-701-14

1 x 2



**MIKULICZ**  
 18,0 cm, 7"  
 040-703-18

1 x 2



**MIKULICZ**  
 20,0 cm, 8"  
 040-709-20

1 x 2



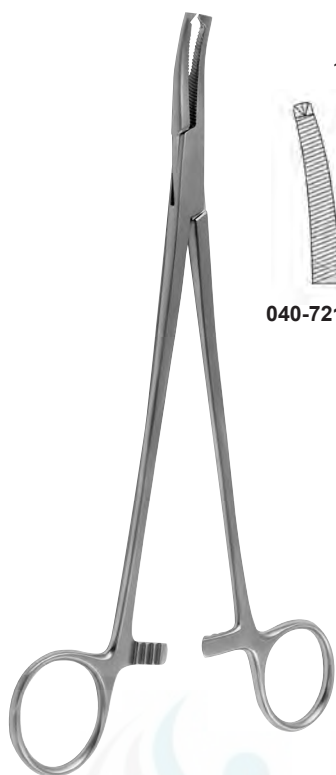

**FAURE**  
20,0 cm, 8"



**PHANEUF**  
21,5 cm, 8½"

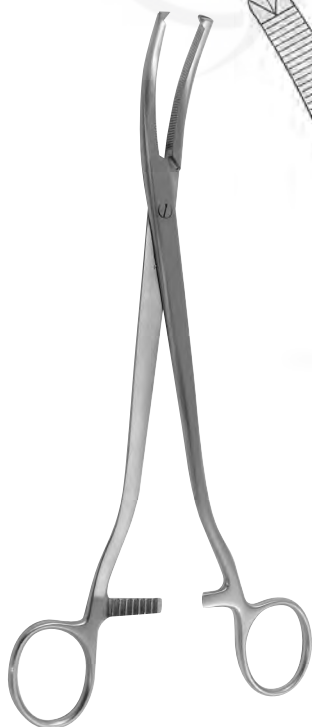

**WERTHEIM**  
24,0 cm, 9½"  
040-601-24

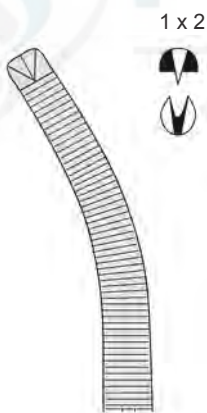

**WERTHEIM**  
25,0 cm, 10"  
040-602-25

Hysterektomieklemmen  
 Hysterectomy Forceps  
 Pinzas-clamps para histerectomía  
 Pinze per isterectomia



**WERTHEIM**  
 23,0 cm, 9"

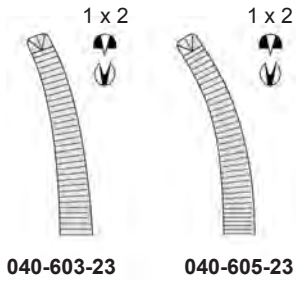

**MAINGOT**  
 21,5 cm, 8 1/2"

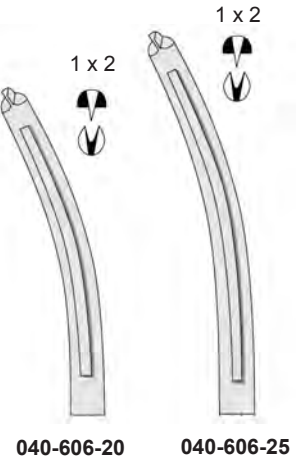

**MOYNIHAN**

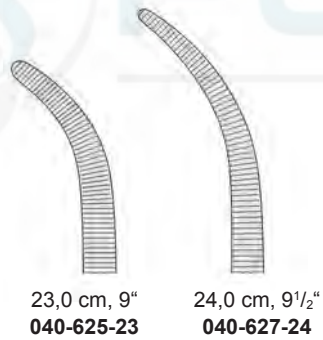

**WERTHEIM-CULLEN**  
 21,5 cm, 8 1/2"  
 040-629-21



**LONG**  
19,0 cm, 7<sup>1</sup>/<sub>4</sub>"  
040-621-19

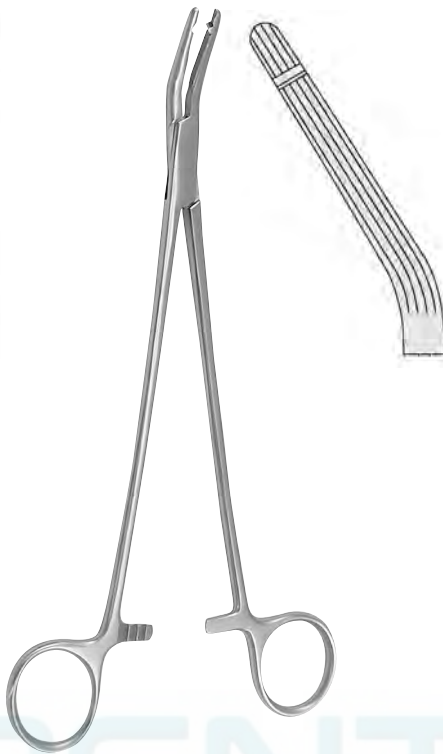

**GARLAND**  
21,0 cm, 8<sup>1</sup>/<sub>4</sub>"  
040-623-21



**HEANEY**  
21,0 cm, 8<sup>1</sup>/<sub>4</sub>"  
040-607-21



**HEANEY-BALLANTINE**  
21,0 cm, 8<sup>1</sup>/<sub>4</sub>"

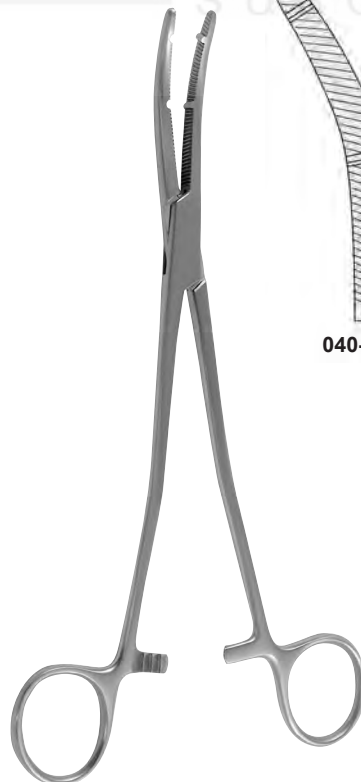
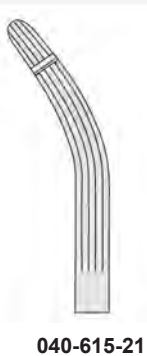
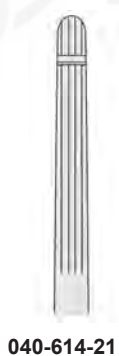

**HEANEY-KANTER**  
21,0 cm, 8<sup>1</sup>/<sub>4</sub>"

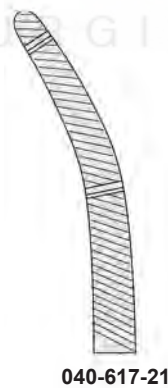

Hysterektomieklemmen  
Hysterectomy Forceps  
Pinzas-clamps para histerectomía  
Pinze per isterectomia



HEANEY

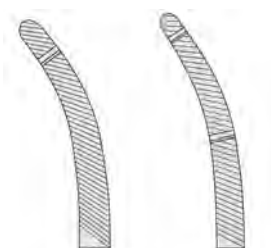

21,0 cm, 8 <sup>1</sup> / <sub>4</sub> "	<b>040-611-21</b>	<b>040-613-21</b>
23,0 cm, 9"	<b>040-611-23</b>	<b>040-613-23</b>



**Nahtinstrumente**  
**Suture Instruments**  
**Instrumentos para sutura**  
**Strumenti per sutura**

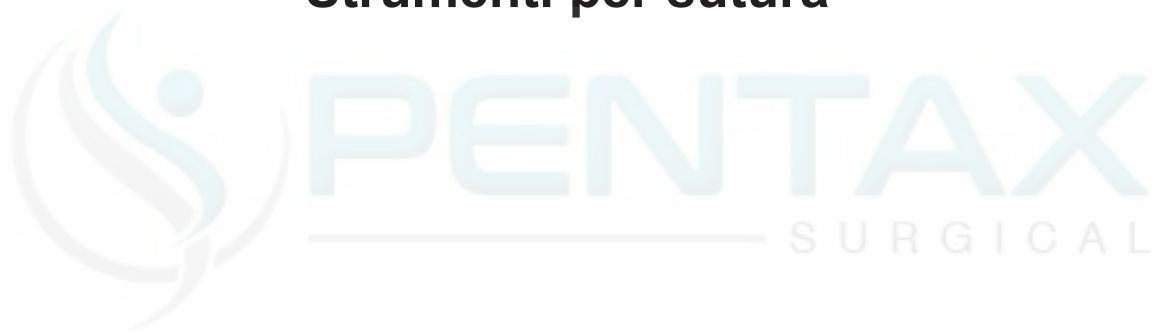



**DERF**



**COLLIER**  
12,5 cm, 5"  
**050-022-12**



**WEBSTER**  
13,0 cm, 5"  
**050-028-13**



**HALSEY**  
13,0 cm, 5"

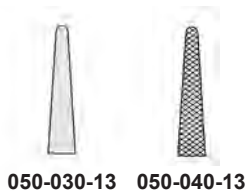

**NEIVERT**  
13,0 cm, 5"  
**050-046-13**



**HEGAR-BAUMGARTNER**  
14,0 cm, 5<sup>1</sup>/<sub>2</sub>"  
**050-048-14**



**050-096-13**  
13,0 cm, 5"

**BROWN**



**CRILE-MURRAY**  
15,0 cm, 6"  
**050-070-15**



**050-060-15**  
15,0 cm, 6"

**CRILE-WOOD**



**ADSON**  
18,0 cm, 7"  
**050-192-18**



**METZENBAUM**  
18,0 cm, 7"  
**050-190-18**



**MASS.-GENERAL-HOSPITAL**  
17,0 cm, 6<sup>3</sup>/<sub>4</sub>"  
**050-072-17**



**MAYO-HEGAR**

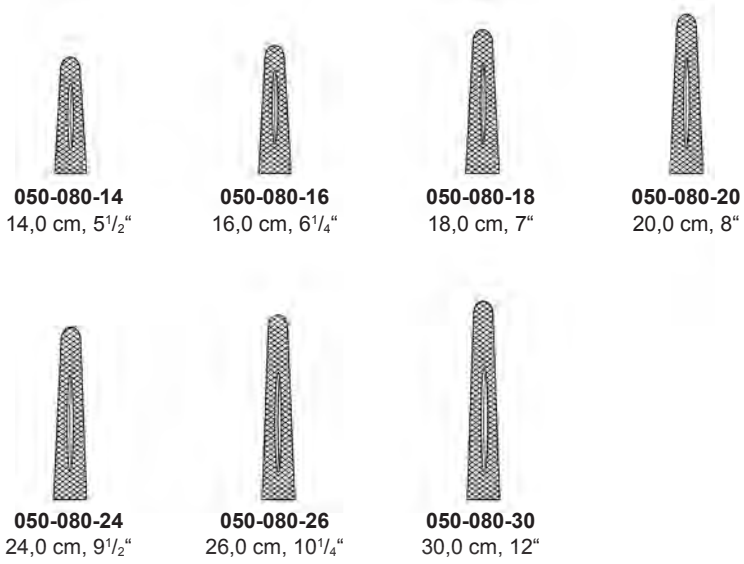

PENTAX  
SURGICAL



**MAYO-HEGAR-DELICATE**



**LAWRENCE**  
15,0 cm, 6"  
**050-110-15**



**HEANEY**  
21,0 cm, 8<sup>1</sup>/<sub>4</sub>"  
050-141-21



**JAMISON**  
23,5 cm, 9<sup>1</sup>/<sub>4</sub>"  
050-148-23



**MASSON**  
27,0 cm, 10<sup>1</sup>/<sub>2</sub>"  
050-150-27



**FINOCCHIETTO**  
27,0 cm, 10<sup>1</sup>/<sub>2</sub>"  
050-211-27



**WANGENSTEEN**  
27,0 cm, 10<sup>1</sup>/<sub>2</sub>"  
050-160-27



**JOHNSON**  
27,0 cm, 10<sup>1</sup>/<sub>2</sub>"  
050-193-27



**STRATTE**  
23,0 cm, 9"  
050-230-23



**OLSEN-HEGAR**  
17,0 cm, 6<sup>3</sup>/<sub>4</sub>"  
050-310-17

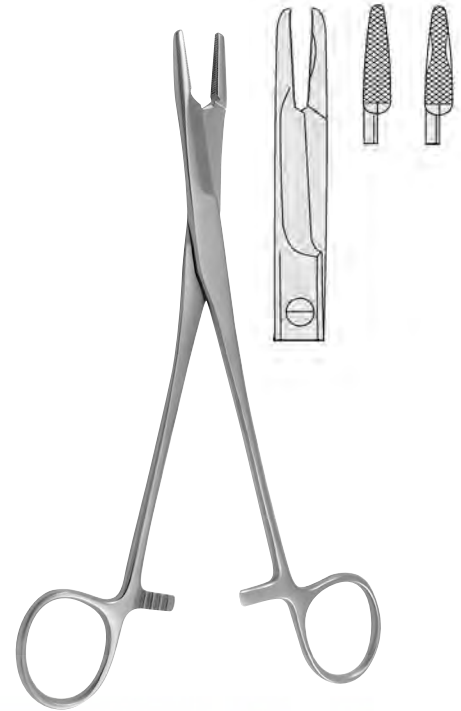

**OLSEN-HEGAR**  
14,0 cm, 5<sup>1</sup>/<sub>2</sub>"  
050-306-14



**OLSEN-HEGAR**

14,0 cm, 5<sup>1</sup>/<sub>2</sub>"  
050-310-14

18,0 cm, 7"  
050-310-18



**TOENNIS**  
18,0 cm, 7"  
050-362-18



MATHIEU

**050-350-14**  
14,0 cm, 5½"



**050-350-17**  
17,0 cm, 6¾"



**050-350-20**  
20,0 cm, 8"



MATHIEU

**050-356-17**  
17,0 cm, 6¾"



**050-356-20**  
20,0 cm, 8"



LICHTENBERG  
20,0 cm, 8"  
050-366-20



MATHIEU

**050-354-14**  
14,0 cm, 5½"



**050-354-17**  
17,0 cm, 6¾"



Nadelhalter, Mikro-Nadelhalter  
 Needle Holders, Micro Needle Holders  
 Porta-agujas, Micro Porta-agujas  
 Portaghi, Micro Portaghi



**050-358-14**  
 14,0 cm, 5½"



**050-358-17**  
 17,0 cm, 6¾"



**050-358-20**  
 20,0 cm, 8"



**050-550-10**



**050-551-10**



**MATHIEU-KOCHER**

**BARRAQUER-TROUTMAN**  
 10,0 cm, 4"



**050-553-10** **050-553-13**



**BARRAQUER**



**BARRAQUER**  
 13,5 cm, 5⅜"  
**050-621-13**



**GOMEL**  
 14,0 cm, 5½"  
**050-601-14**



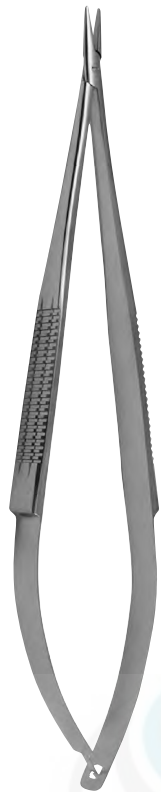

050-600-18



050-601-18



ohne Sperre  
without ratchet  
sin cremallera  
senza cremagliera

18,5 cm, 7 1/4"



050-630-18



050-631-18

mit Sperre  
with ratchet  
con cremallera  
con cremagliera

18,5 cm, 7 1/4"



050-570-14



050-571-14



050-576-14



050-577-14

mit Sperre  
with ratchet  
con cremallera  
con cremagliera

CASTROVIEJO  
14,5 cm, 5 3/4"



050-570-18



050-571-18

050-576-18



050-577-18

mit Sperre  
with ratchet  
con cremallera  
con cremagliera

CASTROVIEJO  
18,0 cm, 7"

gerade, ohne Sperre  
 straight, without ratchet  
 recta, sin cremallera  
 retta, senza cremagliera

0,4 mm



14,0 cm, 5 1/2"  
**050-650-14**

gebogen, ohne Sperre  
 curved, without ratchet  
 curva, sin cremallera  
 curva, senza cremagliera

0,4 mm

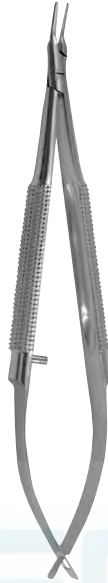

14,0 cm, 5 1/2"  
**050-651-14**

gebogen, mit Sperre  
 curved, with ratchet  
 curva, con cremallera  
 curva, con cremagliera

0,4 mm



14,0 cm, 5 1/2"  
**050-653-14**

gebogen, ohne Sperre  
 curved, without ratchet  
 curva, sin cremallera  
 curva, senza cremagliera

0,5 mm



14,0 cm, 5 1/2"  
**050-661-14**

gebogen, mit Sperre  
 curved, with ratchet  
 curva, con cremallera  
 curva, con cremagliera

0,5 mm



14,0 cm, 5 1/2"  
**050-663-14**

Ø 10 mm

gebogen, ohne Sperre  
 curved, without ratchet  
 curva, sin cremallera  
 curva, senza cremagliera

0,4 mm



13,0 cm, 5"  
**050-671-13**

Ø 8 mm



**KALT**  
13,5 cm, 5<sup>3</sup>/<sub>8</sub>"  
051-428-14



**DIETRICH**

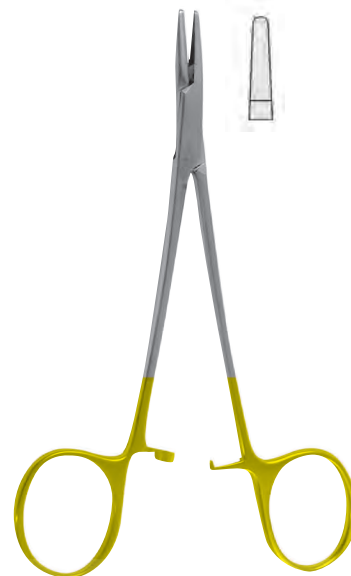
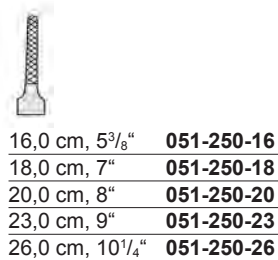

**WEBSTER**  
13,0 cm, 5"  
051-028-13

**PENTAX**  
SURGICAL



**DERF**  
12,0 cm, 4<sup>3</sup>/<sub>4</sub>"  
051-010-12



**HEGAR-BAUMGARTNER**

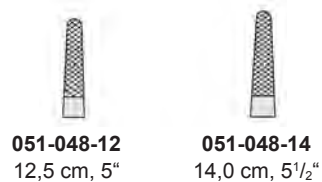

**WEBSTER**  
13,0 cm, 5"  
051-029-13

Nadelhalter mit Hartmetalleinlagen  
Needle Holders with tungsten carbide inserts  
Porta-agujas con bocas de carburo tungsteno  
Portaghi con morsi in carburo di tungsteno



**HALSEY**  
13,0 cm, 5"

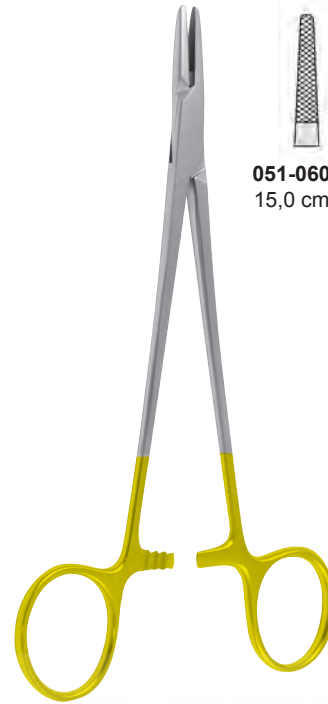

**CRILE-WOOD**

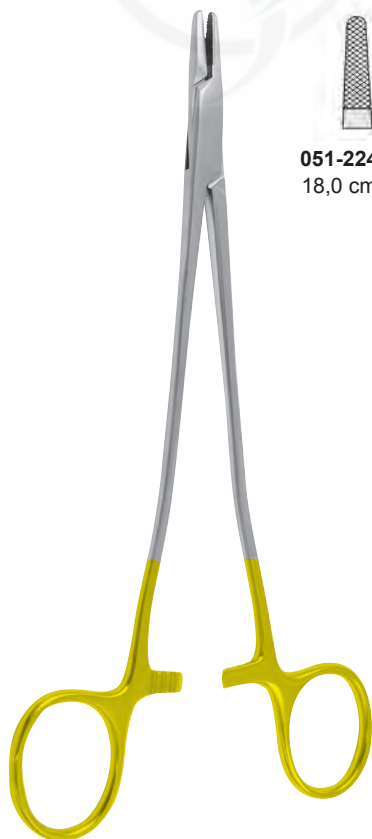

**SAROT**





MAYO-HEGAR



**051-080-16**  
16,0 cm, 6<sup>1</sup>/<sub>4</sub>"



**051-080-18**  
18,0 cm, 7"



**051-080-20**  
20,0 cm, 8"



**051-080-24**  
24,0 cm, 9<sup>1</sup>/<sub>2</sub>"



**051-080-26**  
26,0 cm, 10<sup>1</sup>/<sub>4</sub>"



**051-080-30**  
30,0 cm, 12"



MAYO-HEGAR (HEANEY)



**051-141-20**  
20,0 cm, 8"



**051-141-24**  
24,0 cm, 9<sup>1</sup>/<sub>4</sub>"



**051-141-26**  
26,0 cm, 10<sup>1</sup>/<sub>4</sub>"

Nadelhalter mit Hartmetalleinlagen  
 Needle Holders with tungsten carbide inserts  
 Porta-agujas con bocas de carburo tungsteno  
 Portaghi con morsi in carburo di tungsteno



DE BAKEY



**051-114-18**  
18,0 cm, 7"



**051-114-20**  
20,0 cm, 8"



**051-114-23**  
23,0 cm, 9"



**051-114-26**  
26,0 cm, 10<sup>1</sup>/<sub>4</sub>"



**051-114-31**  
31,0 cm, 12<sup>1</sup>/<sub>4</sub>"

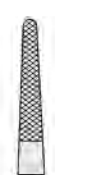

**051-114-37**  
37,0 cm, 14<sup>1</sup>/<sub>2</sub>"



RYDER-VASCULAR



**051-132-13**  
13,0 cm, 5"



**051-132-15**  
15,0 cm, 6"



**051-132-18**  
18,0 cm, 7"



**051-132-20**  
20,0 cm, 8"



**051-132-23**  
23,0 cm, 9"



**051-132-26**  
26,0 cm, 10<sup>1</sup>/<sub>4</sub>"

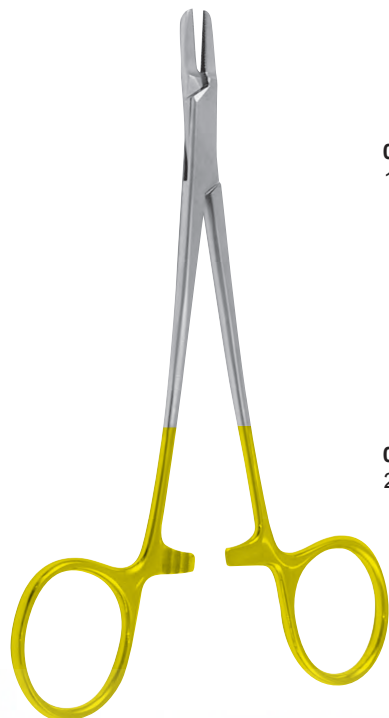

**051-134-13**  
13,0 cm, 5"



**051-134-15**  
15,0 cm, 6"



**051-134-18**  
18,0 cm, 7"



**051-134-20**  
20,0 cm, 8"



**051-134-23**  
23,0 cm, 9"



**051-134-26**  
26,0 cm, 10<sup>1</sup>/<sub>4</sub>"

**RYDER**

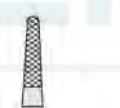

**051-136-15**  
15,0 cm, 6"



**051-136-17**  
17,0 cm, 6<sup>3</sup>/<sub>4</sub>"



**051-136-20**  
20,0 cm, 8"

**SCHWEDISCHES MODELL**

Nadelhalter mit Hartmetalleinlagen  
 Needle Holders with tungsten carbide inserts  
 Porta-agujas con bocas de carburo tungsteno  
 Portaghi con morsi in carburo di tungsteno

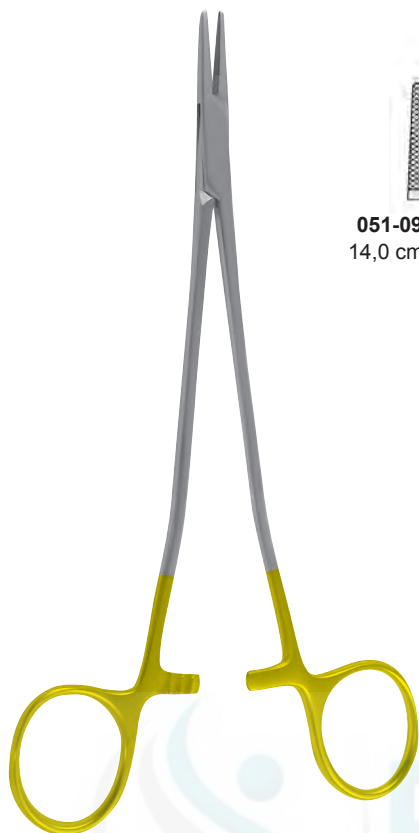

MAYO-HEGAR (HEANEY)



051-090-14  
 14,0 cm, 5½"



051-090-18  
 18,0 cm, 7"



051-090-20  
 20,0 cm, 8"



051-090-23  
 23,0 cm, 9"



FINOCCHIETTO  
 27,0 cm, 10½"  
 051-211-27

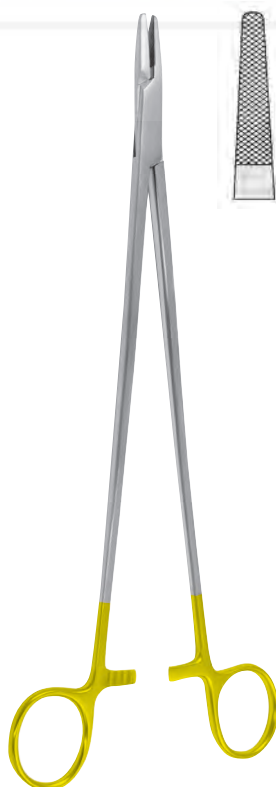

MASSON  
 27,0 cm, 10½"  
 051-150-27



WANGENSTEEN  
 27,0 cm, 10½"  
 051-160-27

Nadelhalter mit Hartmetalleinlagen  
 Needle Holders with tungsten carbide inserts  
 Porta-agujas con bocas de carburo tungsteno  
 Portaghi con morsi in carburo di tungsteno

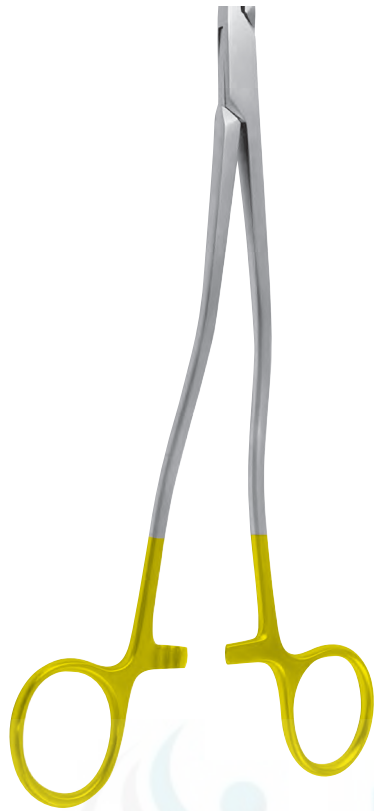

**BOZEMANN**



**051-185-20**  
20,0 cm, 8"



**051-185-24**  
24,0 cm, 9<sup>5</sup>/<sub>8</sub>"



**051-185-26**  
26,0 cm, 10<sup>1</sup>/<sub>4</sub>"

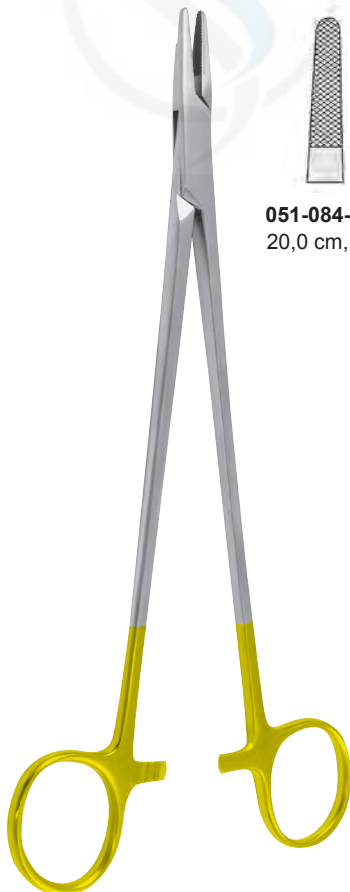

**HEGAR**



**051-084-20**  
20,0 cm, 8"



**051-084-24**  
24,0 cm, 9<sup>5</sup>/<sub>8</sub>"



**BARRY STERNAL**



**051-240-15**  
15,0 cm, 6"



**051-242-20**  
20,0 cm, 8"

Nadelhalter mit Hartmetalleinlagen  
 Needle Holders with tungsten carbide inserts  
 Porta-agujas con bocas de carburo tungsteno  
 Portaghi con morsi in carburo di tungsteno



STRATTE



051-230-22  
 22,0 cm, 8<sup>5</sup>/<sub>8</sub>"



051-230-23  
 23,0 cm, 9"

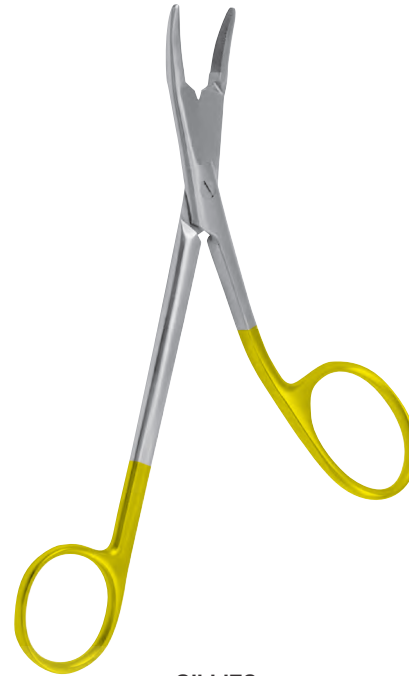

GILLIES  
 16,0 cm, 6<sup>1</sup>/<sub>4</sub>"  
 051-330-16

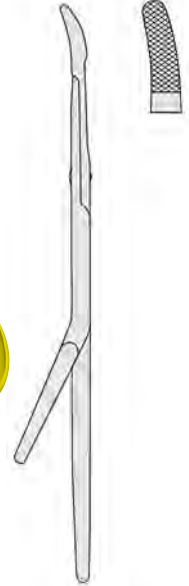

OLSEN-HEGAR



051-310-14  
 14,0 cm, 5<sup>1</sup>/<sub>2</sub>"



051-310-17  
 17,0 cm, 6<sup>3</sup>/<sub>4</sub>"



051-310-18  
 18,0 cm, 7"



TOENNIS  
 18,0 cm, 7"  
 051-362-18



MATHIEU-KOCHER

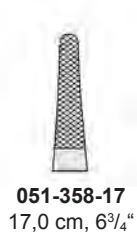

MATHIEU



Nadelhalter mit Hartmetalleinlagen  
Needle Holders with tungsten carbide inserts  
Porta-agujas con bocas de carburo tungsteno  
Portaghi con morsi in carburo di tungsteno



**051-366-17**  
17,0 cm, 6<sup>3</sup>/<sub>4</sub>"



**051-366-20**  
20,0 cm, 8"

**LICHTENBERG**



**051-356-17**  
17,0 cm, 6<sup>3</sup>/<sub>4</sub>"



**051-356-20**  
20,0 cm, 8"



**051-356-23**  
23,0 cm, 9"

**MATHIEU**

Nadelhalter mit Hartmetalleinlagen  
 Needle Holders with tungsten carbide inserts  
 Porta-agujas con bocas de carburo tungsteno  
 Portaghi con morsi in carburo di tungsteno



ZWEIFEL

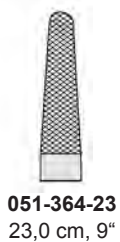
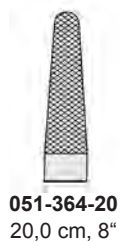

LANGENBECK

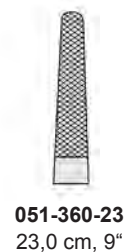
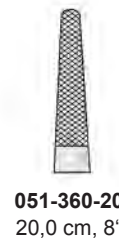

Nadelhalter mit Hartmetalleinlagen  
 Needle Holders with tungsten carbide inserts  
 Porta-agujas con bocas de carburo tungsteno  
 Portaghi con morsi in carburo di tungsteno

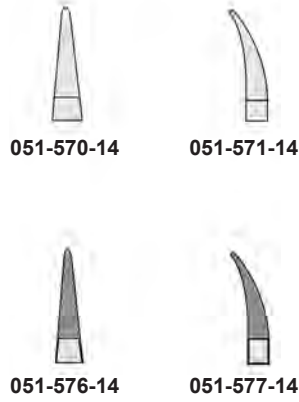

mit Sperre  
 with ratchet  
 con cremallera  
 con cremagliera

**CASTROVIEJO**  
 14,5 cm, 5<sup>3</sup>/<sub>4</sub>"

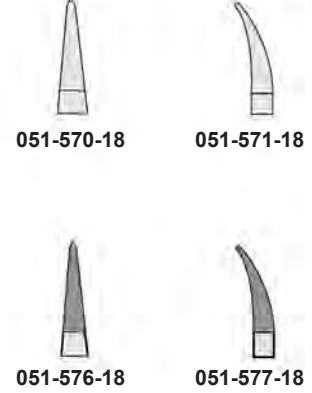

mit Sperre  
 with ratchet  
 con cremallera  
 con cremagliera

**CASTROVIEJO**  
 18,0 cm, 7"

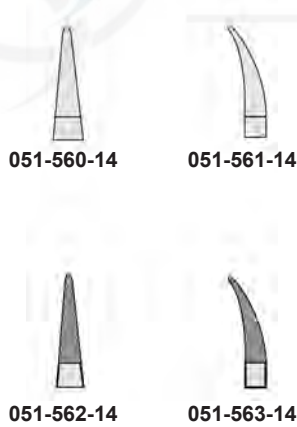

mit Sperre  
 with ratchet  
 con cremallera  
 con cremagliera

**BARRAQUER**  
 14,5 cm, 5<sup>3</sup>/<sub>4</sub>"



**HEPP SCHEIDEL**  
 18,0 cm, 7"  
 051-390-18



REVERDIN  
14,0 cm, 5½"



056-211-01



056-211-02



056-211-03



056-211-04



REVERDIN



19,5 cm, 7¾"  
22,5 cm, 8¾"

056-221-01



056-221-02



056-221-03



056-221-04

056-223-01

056-223-02

056-223-03

056-223-04

Unterbindungsnadeln  
Ligature Needles  
Agujas para ligaduras  
Aghi per legatura

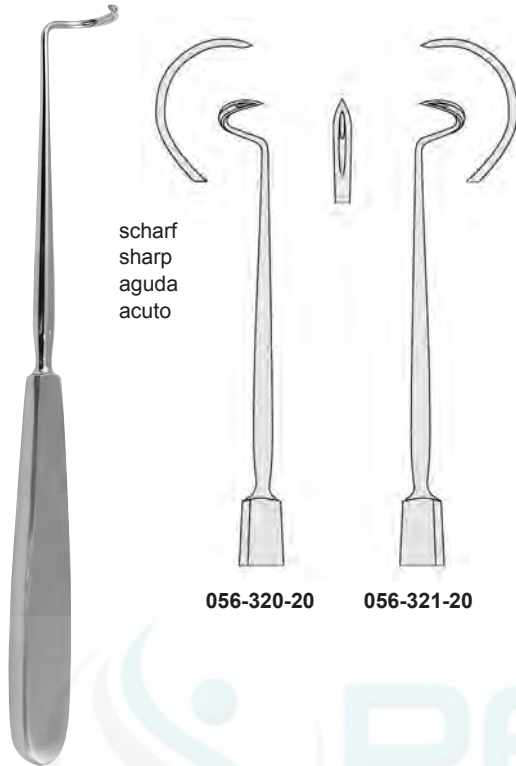

scharf  
sharp  
aguda  
acuto

056-320-20

056-321-20

**DESCHAMPS**  
20,0 cm, 8"

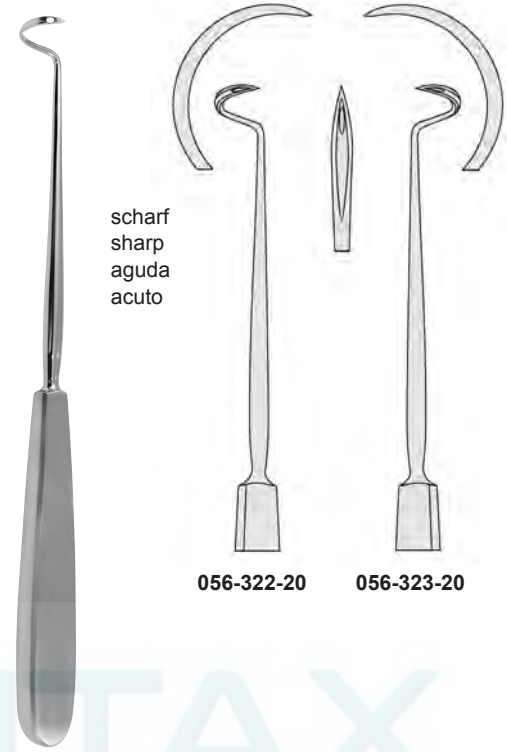

scharf  
sharp  
aguda  
acuto

056-322-20

056-323-20

**DESCHAMPS**  
20,0 cm, 8"

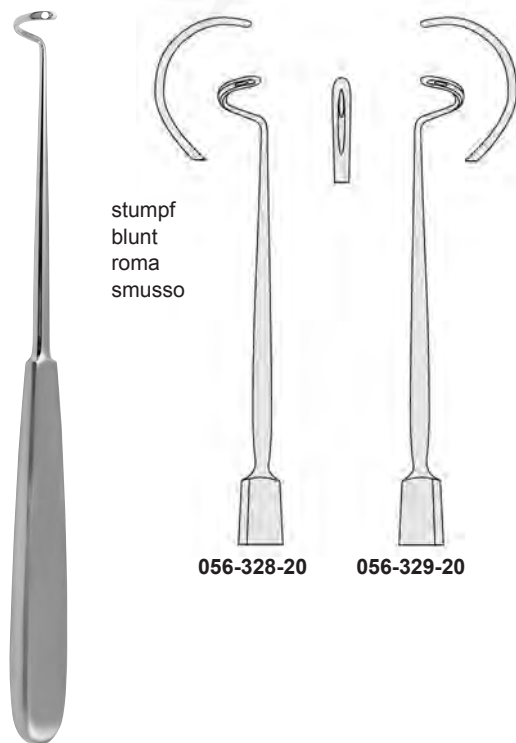

stumpf  
blunt  
roma  
smusso

056-328-20

056-329-20

**DESCHAMPS**  
20,0 cm, 8"

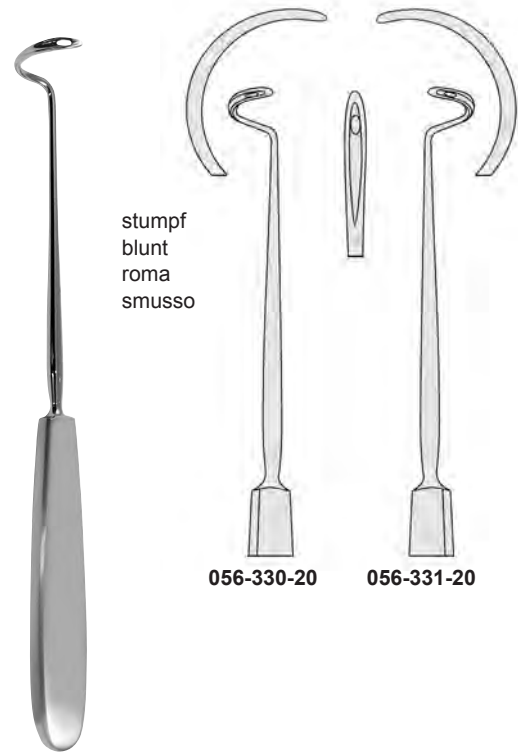

stumpf  
blunt  
roma  
smusso

056-330-20

056-331-20

**DESCHAMPS**  
20,0 cm, 8"

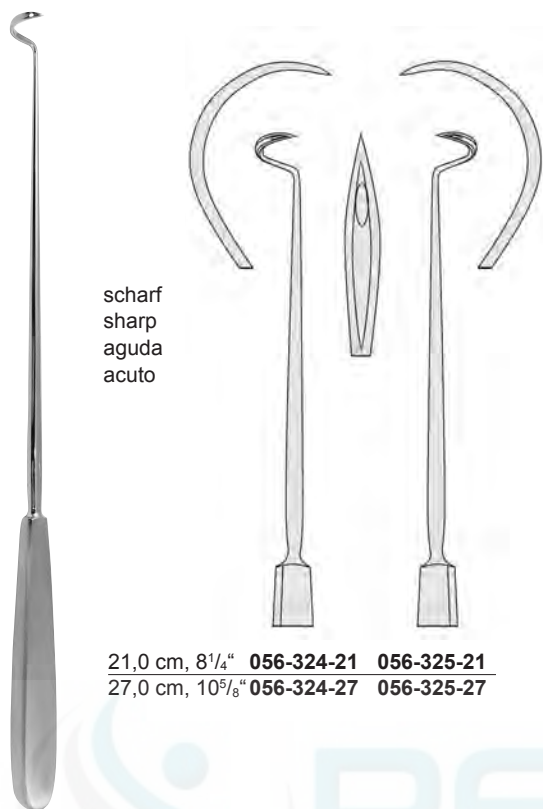

scharf  
sharp  
aguda  
acuto

21,0 cm, 8<sup>1</sup>/<sub>4</sub>" 056-324-21 056-325-21  
27,0 cm, 10<sup>5</sup>/<sub>8</sub>" 056-324-27 056-325-27

DESCHAMPS

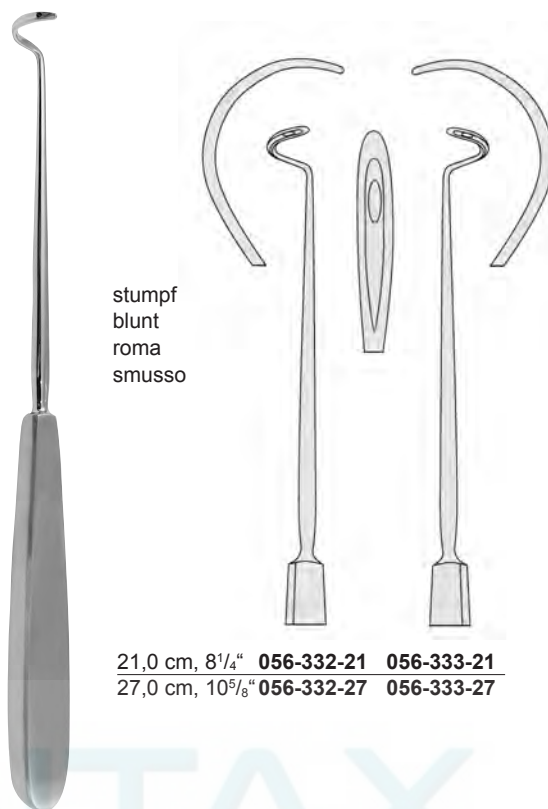

stumpf  
blunt  
roma  
smusso

21,0 cm, 8<sup>1</sup>/<sub>4</sub>" 056-332-21 056-333-21  
27,0 cm, 10<sup>5</sup>/<sub>8</sub>" 056-332-27 056-333-27

DESCHAMPS



biegsam  
malleable  
maleable  
malleabile

20,0 cm, 8"  
056-450-20

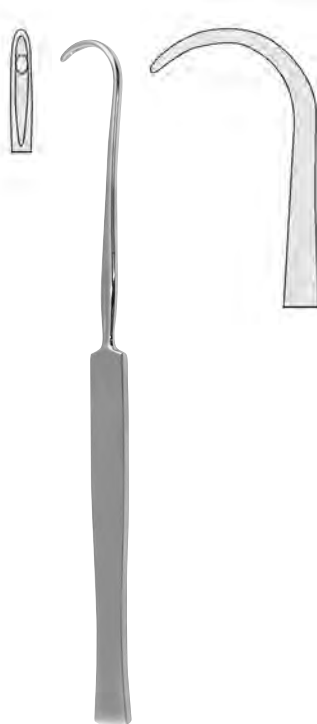

COOPER  
19,0 cm, 7<sup>1</sup>/<sub>2</sub>"  
056-451-19

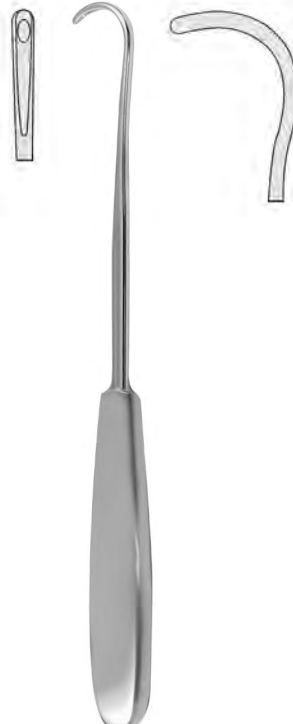

COOPER  
20,0 cm, 8"  
056-451-20



SYME  
15,0 cm, 6"  
056-453-15

Unterbindungsnadeln  
Ligature Needles  
Agujas para ligaduras  
Aghi per legatura



056-452-01



056-452-02



056-452-03



**KOCHER**  
19,0 cm, 7<sup>1</sup>/<sub>2</sub>"

**BRUNNER**  
25,0 cm, 9<sup>3</sup>/<sub>4</sub>"  
056-455-25



056-454-01



056-454-02

**BRUNNER**  
30,0 cm, 11<sup>3</sup>/<sub>4</sub>"

**SCHMIEDEN**  
21,0 cm, 8<sup>1</sup>/<sub>4</sub>"  
056-458-21

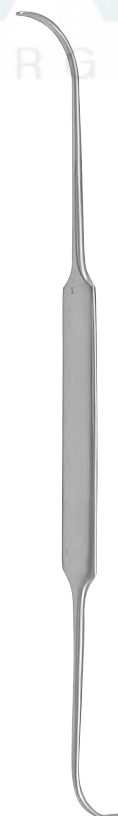



**YOUNG-HRYNTSCHAK**  
24,0 cm, 9 1/2"  
056-460-24



056-460-01



056-460-02



056-460-03

**PENTAX**  
SURGICAL



**DE LA ROZA**  
12,0 cm, 4 3/4"  
056-467-01



**DE LA ROZA**  
12,0 cm, 4 3/4"  
056-467-02



**JAKOBI**  
14,0 cm, 5 1/2"  
056-469-14



**HESSEBERG**  
15,0 cm, 6"  
056-468-15



**KRONECKER**  
15,0 cm, 6"  
056-470-01

Unterbindungsnadeln  
 Ligature Needles  
 Aguja para ligaduras  
 Aghi per legatura



**KRONECKER**  
 15,0 cm, 6"  
 056-470-02



**TRELAT**  
 23,0 cm, 9"  
 056-472-23



**CLAUS**  
 23,0 cm, 9"  
 056-473-23



**HURD**  
 21,0 cm, 8 1/4"  
 056-474-01



**HURD**  
 21,0 cm, 8 1/4"  
 056-474-02



**NAGER**  
 24,0 cm, 9 1/2"  
 056-477-24

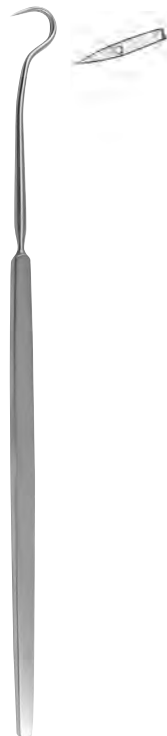

**CLAUS-EICKEN**  
 23,0 cm, 9"  
 056-481-23

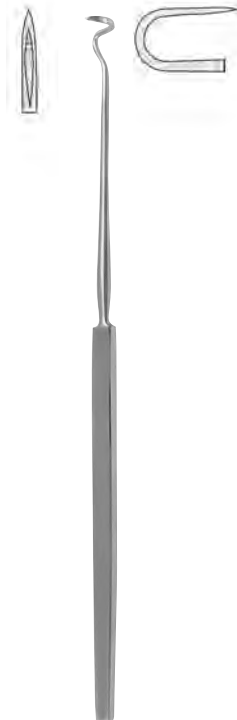

**FALK**  
 24,0 cm, 9 1/2"  
 056-480-01

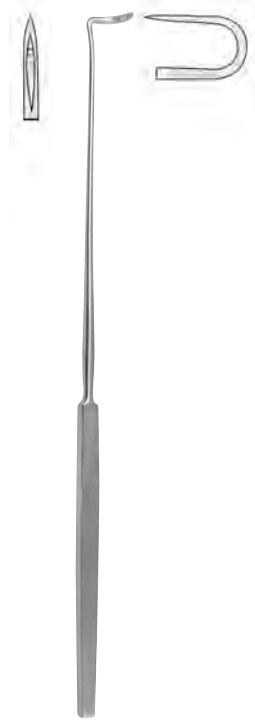

**FALK**  
 24,0 cm, 9 1/2"  
 056-480-02

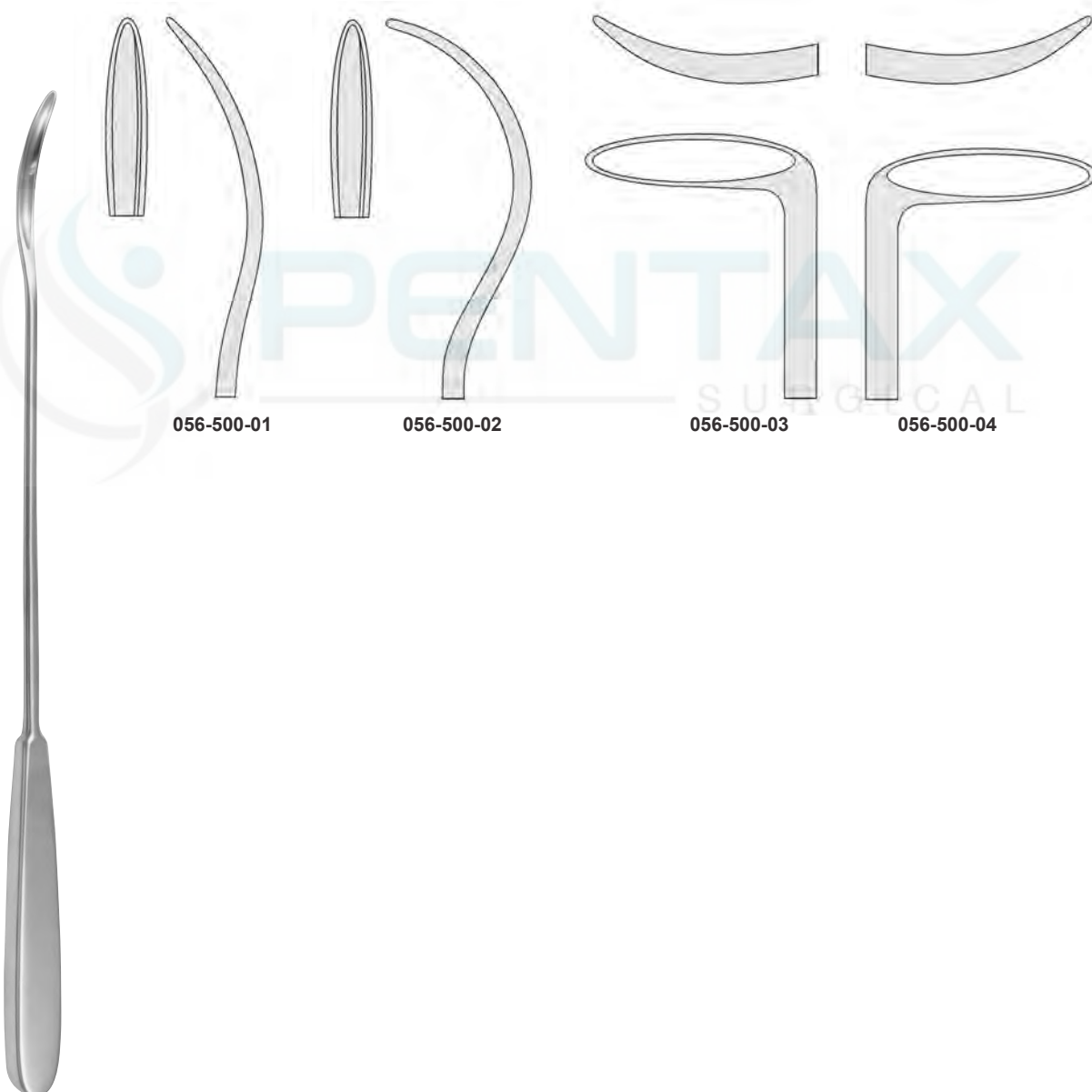

**BRUNNER**  
30,0 cm, 11<sup>3</sup>/<sub>4</sub>"



**PAYR**  
 22,0 cm, 8<sup>5</sup>/<sub>8</sub>"  
 056-502-22



**PAYR**  
 22,0 cm, 8<sup>5</sup>/<sub>8</sub>"  
 056-503-22



mit Loch  
 with hole  
 con foro  
 con ago



**SCHMIEDEN-PAYR**  
 19,0 cm, 7<sup>1</sup>/<sub>2</sub>"  
 056-506-19



ohne Loch  
 without hole  
 sin foro  
 senza ago



**SCHMIEDEN**  
 19,0 cm, 7<sup>1</sup>/<sub>2</sub>"  
 056-507-19



**KÖNIG**  
 19,5 cm, 7<sup>3</sup>/<sub>4</sub>"  
 056-508-03



**KÖNIG**  
 19,5 cm, 7<sup>3</sup>/<sub>4</sub>"  
 056-508-05



**KÖNIG**  
 19,5 cm, 7<sup>3</sup>/<sub>4</sub>"  
 056-508-07



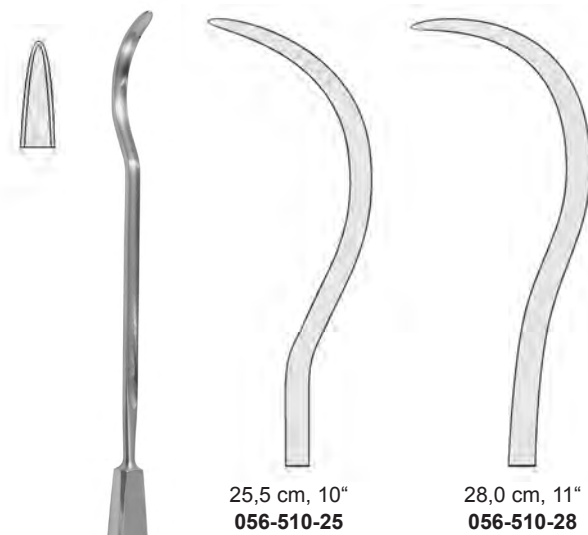

**KIRSCHNER**

25,5 cm, 10"  
**056-510-25**

28,0 cm, 11"  
**056-510-28**



**BRUNNER-FERROZELL**  
18,0 cm, 7" **056-521-18**  
27,0 cm, 10<sup>5</sup>/<sub>8</sub>" **056-521-27**



**KOCHER**

15,0 cm, 6" **056-513-15** **056-514-15**  
16,0 cm, 6<sup>1</sup>/<sub>4</sub>" **056-513-16** **056-514-16**

18,0 cm, 7"  
**056-516-18**



**MOD. WIEN**  
23,5 cm, 9<sup>1</sup>/<sub>4</sub>"  
056-532-23



**BOZEMANN**  
21,0 cm, 8<sup>1</sup>/<sub>4</sub>"  
056-531-21



23,0 cm, 9"  
056-530-23



**MICHEL**  
12,0 cm, 4<sup>3</sup>/<sub>4</sub>"  
056-550-12

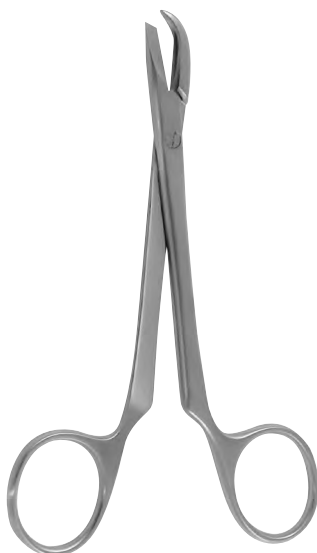

**COLLIN**  
13,0 cm, 5"  
056-552-13



**RICHTER-HEATH**  
14,0 cm, 5<sup>1</sup>/<sub>2</sub>"  
056-553-14



**WACHENFELDT**  
12,5 cm, 5"  
056-555-01



**HEGENBARTH**  
12,5 cm, 5"  
056-556-12



**MICHEL**  
12,0 cm, 4<sup>3</sup>/<sub>4</sub>"  
056-558-12



**LANGE**  
10,0 cm, 4"  
056-559-10

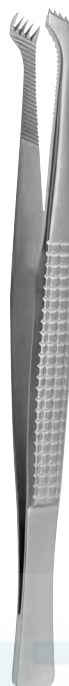

**CHILDE**  
18,0 cm, 7"  
056-560-01



**CHILDE CLIP**  
18,0 cm, 7"  
056-560-02



**MICHEL**

<b>056-570-08</b>	7,5 x 1,75 mm
<b>056-570-11</b>	11,0 x 2,0 mm
<b>056-570-12</b>	12,0 x 3,0 mm
<b>056-570-14</b>	14,0 x 3,0 mm
<b>056-570-16</b>	16,0 x 3,0 mm
<b>056-570-18</b>	18,0 x 3,0 mm
<b>056-570-20</b>	20,0 x 3,0 mm
<b>056-570-22</b>	22,0 x 3,0 mm



**CLIP-SET**  
**056-558-00**

bestehend aus, consisting of,  
compuesto de, composto da

- 1 x **056-558-12**
- 1 x **056-550-12**
- 50 x **056-570-14**
- 1 x **056-590-01** (Etui)

**Wundhaken  
Retractors  
Separadores  
Divaricatori**

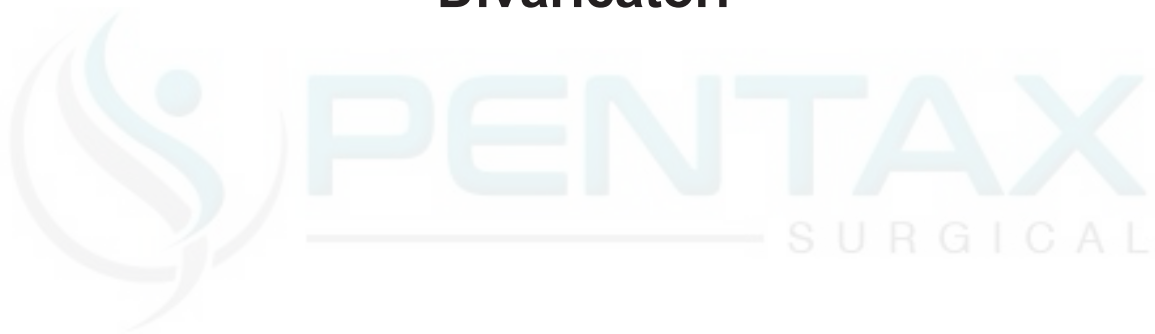



Fig. 1  
062-050-01



Fig. 2  
062-050-02

**GILLIES**  
18,0 cm, 7"



**KILNER**  
15,0 cm, 6"  
062-054-15



**FRAZIER**  
13,0 cm, 5"  
062-060-13



**O'CONNOR**  
16,0 cm, 6 1/4"  
062-074-16



Fig. 1  
062-058-01



Fig. 2  
062-058-02



Fig. 3  
062-058-03

**KLEINERT-KUTZ**  
16,0 cm, 6 1/4"



**JOSEPH**  
16,0 cm, 6 1/4"  
062-062-16



Fig. 1  
062-078-01



Fig. 2  
062-078-02

**GRAEFE**  
16,0 cm, 6 1/4"



16,0 cm, 6 1/4"



**GUTHRIE**  
16,0 cm, 6 1/4"



**JOSEPH**  
16,0 cm, 6 1/4"



**KNAPP**  
13,0 cm, 5"



Fig. 1  
**062-082-01**

scharf  
sharp  
agudos  
acuti



Fig. 2  
**062-082-02**

stumpf  
blunt  
romo  
smusso



16,0 cm, 6 1/4"



**062-088-02**



**062-088-03**



**062-088-04**



**062-089-02**



**062-089-03**



**062-089-04**



flexibel · flexible · flexibles · flessibili



16,0 cm, 6 1/4"



**062-101-01**



**062-101-02**



**062-101-03**



**062-101-04**

scharf  
sharp  
agudos  
acuti



**062-103-01**



**062-103-02**



**062-103-03**



**062-103-04**

halbscharf  
semi-sharp  
semi-agudos  
semi-acuti



**062-102-01**



**062-102-02**



**062-102-03**



**062-102-04**

stumpf  
blunt  
romo  
smusso



16,0 cm, 6 1/4"



062-111-01



062-111-02



062-111-03



062-111-04

scharf  
sharp  
agudos  
acuti



062-112-01



062-112-02



062-112-03



062-112-04

stumpf  
blunt  
romo  
smusso



**CUSHING**  
19,0 cm, 7 1/2"

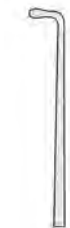

Fig. 1  
062-140-01



Fig. 2  
062-140-02



**LANGENBECK-GREEN**  
16,0 cm, 6 1/4"



16 x 6 mm  
062-162-01



24 x 6 mm  
062-162-02

Wundhaken  
Retractors  
Separadores  
Divaricatori

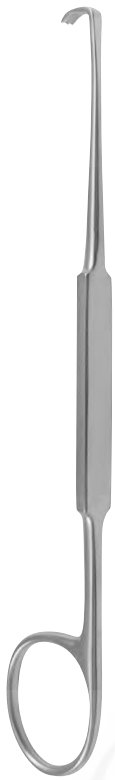

**MEYERDING**  
18,0 cm, 7"



18 x 7 mm  
**062-150-01**



16 x 5 mm  
**062-150-02**



7 x 4 mm  
**062-150-03**



14 x 8 mm  
**062-166-16**



10 x 3 mm  
**062-150-04**



7 x 4 mm  
**062-150-05**



4 x 10 mm  
**062-150-06**



16,0 cm, 6 1/4"



**SENN-GREEN**  
15,0 cm, 6"



10 x 6 mm  
**062-160-10**



20 x 6 mm  
**062-160-20**



**MINI-LANGENBECK**  
16,0 cm, 6 1/4"



10 x 6 mm  
**062-164-01**



17 x 5 mm  
**062-164-02**



20 x 6 mm  
**062-164-03**



22 x 8 mm  
**062-164-04**



8 x 4 mm

**RAGNELL-DAVIS**  
14,0 cm, 5 1/2"  
062-170-14



8 x 4 mm

**RAGNELL**  
15,0 cm, 6"  
062-174-15

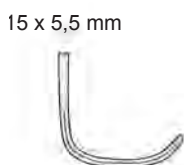

15 x 5,5 mm

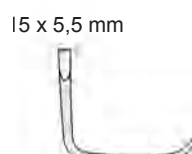

15 x 5,5 mm

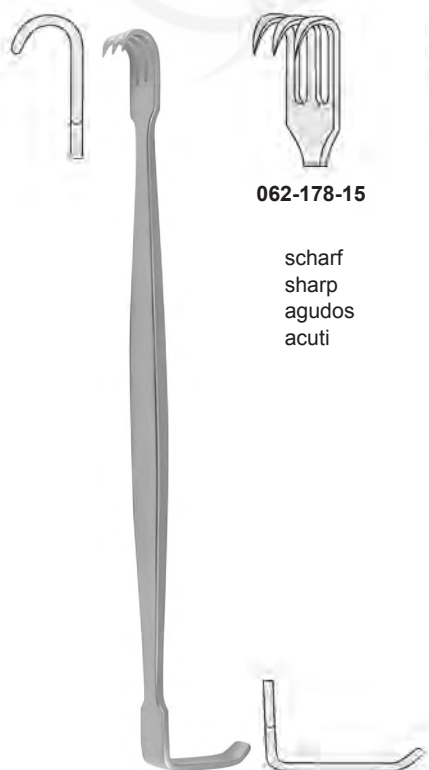

**BABY SENN-MILLER**  
15,0 cm, 6"



062-178-15

scharf  
sharp  
agudos  
acuti



062-179-15

stumpf  
blunt  
romo  
smusso

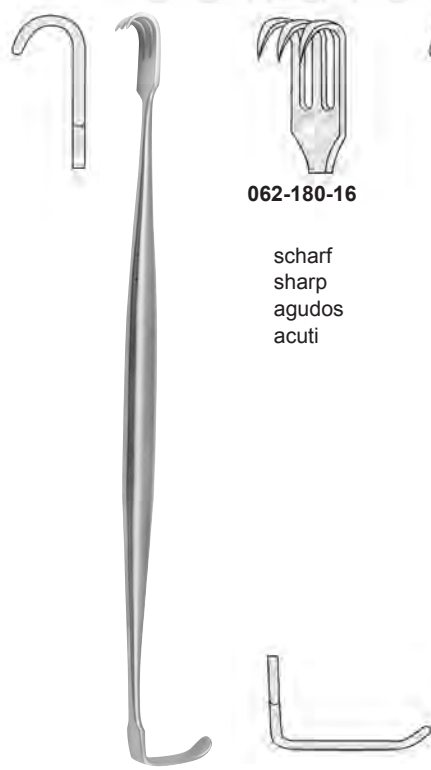

**SENN-MILLER**  
16,0 cm, 6 1/4"



062-180-16

scharf  
sharp  
agudos  
acuti



062-181-16

stumpf  
blunt  
romo  
smusso

Wundhaken  
Retractors  
Separadores  
Divaricatori

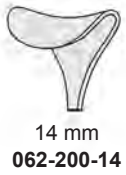

**DESMARRES**  
13,0 cm, 5"

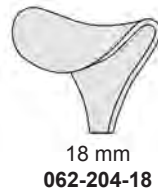
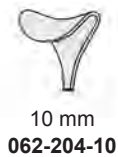

**DESMARRES**  
16,0 cm, 6 1/4"

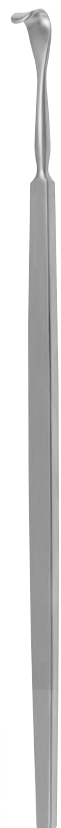

**CUSHING**  
20,0 cm, 8"



8 mm  
**062-210-08**



10 mm  
**062-210-10**



12 mm  
**062-210-12**



14 mm  
**062-210-14**



16 mm  
**062-210-16**



18 mm  
**062-210-18**



**CUSHING**  
24,0 cm, 9 1/2"



8 mm  
**062-212-08**



10 mm  
**062-212-10**



12 mm  
**062-212-12**



14 mm  
**062-212-14**



16 mm  
**062-212-16**



18 mm  
**062-212-18**

Wundhaken  
Retractors  
Separadores  
Divaricatori



**GIL-VERNET**  
24,0 cm, 9 1/2"

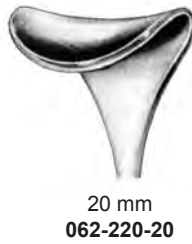

**GIL-VERNET**  
24,0 cm, 9 1/2"

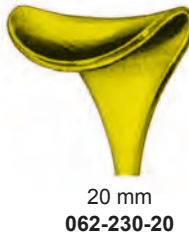



ROUX

- Fig. 1 24 x 20 mm
- Fig. 2 29 x 26 mm
- Fig. 3 33 x 29 mm
- Fig. 4 29 x 24 mm

Satz, Fig. 1-3  
Set, fig. 1-3  
Juego, fig. 1-3  
Serie, fig. 1-3

- Fig. 1 30 x 28 mm
- Fig. 2 36 x 36 mm
- Fig. 3 38 x 43 mm
- Fig. 4 45 x 28 mm

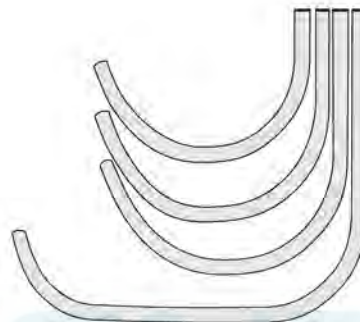
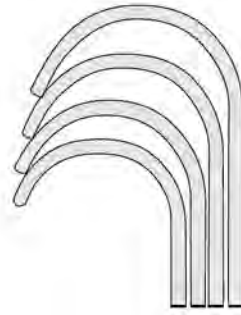

- |          |  |                   |
|----------|--|-------------------|
| Fig. 1-3 | 17,0 cm, 6 <sup>3</sup> / <sub>4</sub> " | <b>062-310-00</b> |
| Fig. 1   | 14,0 cm, 5 <sup>1</sup> / <sub>2</sub> " | <b>062-310-01</b> |
| Fig. 2   | 15,0 cm, 6"                              | <b>062-310-02</b> |
| Fig. 3   | 17,0 cm, 6 <sup>3</sup> / <sub>4</sub> " | <b>062-310-03</b> |
| Fig. 4   | 18,0 cm, 7"                              | <b>062-310-04</b> |



**FARABEUF**  
12,0 cm, 4<sup>3</sup>/<sub>4</sub>"  
**062-300-12**

- Fig. 2 30 x 10 mm
- Fig. 1 26 x 10 mm

- Fig. 1 30 x 13 mm
- Fig. 2 34 x 13 mm

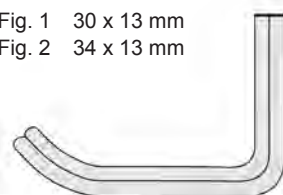

**FARABEUF**  
15,0 cm, 5<sup>3</sup>/<sub>4</sub>"  
**062-302-15**

- Fig. 2 23 x 16 mm
- Fig. 1 27 x 16 mm

- Fig. 1 26 x 16 mm
- Fig. 2 30 x 16 mm

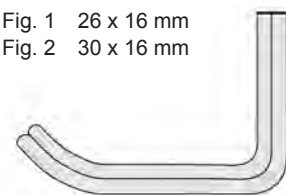
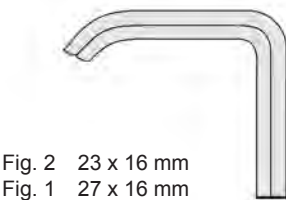

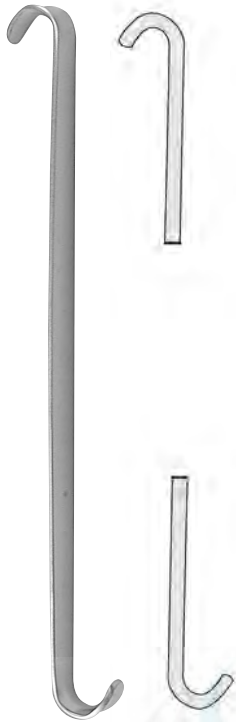

**MINI-ROUX**  
14,0 cm, 5<sup>1</sup>/<sub>2</sub>"  
062-340-06



**BABY-ROUX**  
13,0 cm, 5"  
062-342-13



**PARKER**  
13,5 cm, 5<sup>3</sup>/<sub>8</sub>"  
062-350-00

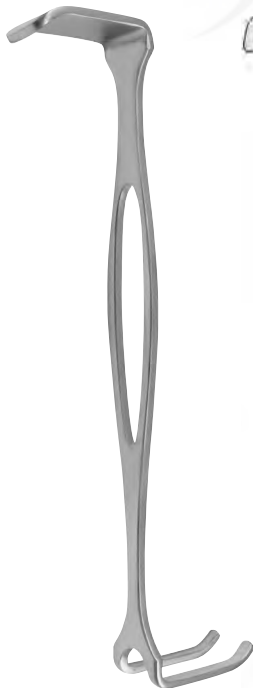
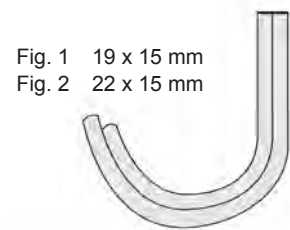
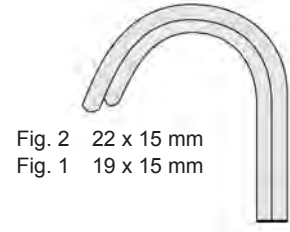

**CZERNY**  
17,5 cm, 7"  
062-360-00



**MATHIEU**  
20,0 cm, 8"  
062-380-00

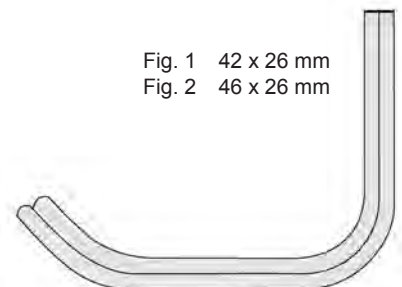
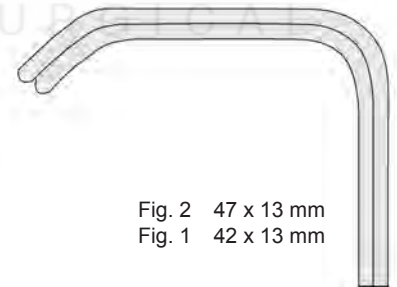

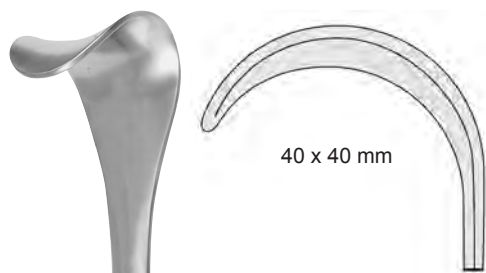

40 x 40 mm

**GOELET**  
19,0 cm, 7½"  
062-396-19

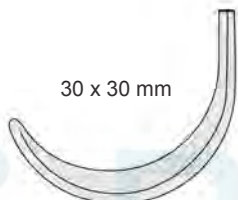

30 x 30 mm

**PARKER-LANGENBECK**  
21,0 cm, 8¼"  
062-390-00

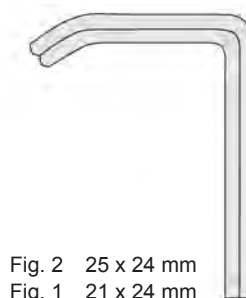

Fig. 2 25 x 24 mm  
Fig. 1 21 x 24 mm

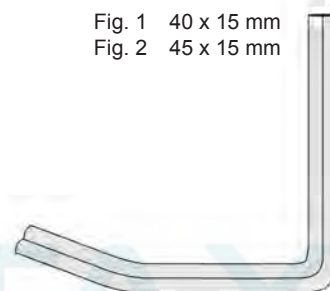
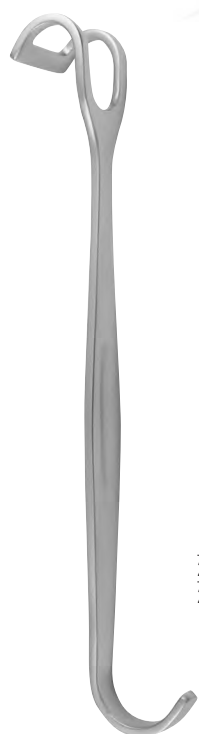

Fig. 1 40 x 15 mm  
Fig. 2 45 x 15 mm



16 mm	19,0 cm, 7½"	062-370-16
20 mm	19,0 cm, 7½"	062-370-20
25 mm	20,0 cm, 8"	062-370-25

**CANNY RYAL**



**VOLKMANN**  
21,5 cm, 8½"



**064-001-01**



9 x 8 mm  
**064-001-02**



9 x 13 mm  
**064-001-03**



9 x 19 mm  
**064-001-04**



9 x 29 mm  
**064-001-06**



9 x 40 mm  
**064-001-08**

scharf  
sharp  
agudos  
acuti



**VOLKMANN**  
21,5 cm, 8½"



**064-003-01**



9 x 8 mm  
**064-003-02**



9 x 13 mm  
**064-003-03**



9 x 19 mm  
**064-003-04**



9 x 29 mm  
**064-003-06**



9 x 40 mm  
**064-003-08**

halbscharf  
semi-sharp  
semi-agudos  
semi-acuti



**VOLKMANN**  
21,5 cm, 8½"



**064-002-01**



9 x 8 mm  
**064-002-02**



9 x 13 mm  
**064-002-03**



9 x 19 mm  
**064-002-04**



9 x 29 mm  
**064-002-06**



9 x 40 mm  
**064-002-08**

stumpf  
blunt  
romo  
smusso



**KOCHER**  
22,0 cm, 8⅝"



**064-011-01**



9 x 8 mm  
**064-011-02**



15 x 15 mm  
**064-011-03**



15 x 20 mm  
**064-011-04**



15 x 30 mm  
**064-011-06**

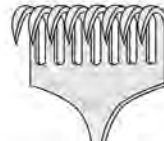

15 x 40 mm  
**064-011-08**

scharf  
sharp  
agudos  
acuti

Wundhaken  
Retractors  
Separadores  
Divaricatori



**KOCHER**  
22,0 cm, 8<sup>5</sup>/<sub>8</sub>"



**064-013-01**



9 x 8 mm  
**064-013-02**



15 x 15 mm  
**064-013-03**



15 x 20 mm  
**064-013-04**



15 x 30 mm  
**064-013-06**

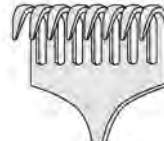

15 x 40 mm  
**064-013-08**

halbscharf  
semi-sharp  
semi-agudos  
semi-acuti



**KOCHER**  
22,0 cm, 8<sup>5</sup>/<sub>8</sub>"



**064-012-01**



9 x 8 mm  
**064-012-02**



15 x 15 mm  
**064-012-03**



15 x 20 mm  
**064-012-04**



15 x 30 mm  
**064-012-06**



15 x 40 mm  
**064-012-08**

stumpf  
blunt  
romo  
smusso



26 x 40 mm  
**064-021-24**

stumpf  
blunt  
romo  
smusso



26 x 40 mm  
**064-022-24**

scharf  
sharp  
agudos  
acuti

**KOERTE**  
24,0 cm, 9<sup>1</sup>/<sub>2</sub>"



55 x 20 mm  
**064-100-55**



60 x 20 mm  
**064-100-60**

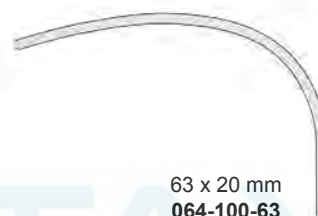

63 x 20 mm  
**064-100-63**

**LANGENBECK**  
21,0 cm, 8<sup>1</sup>/<sub>4</sub>"



**ISRAEL**  
25,0 cm, 9<sup>3</sup>/<sub>4</sub>"

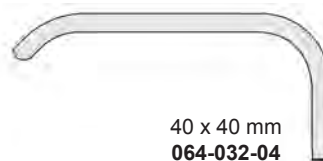

40 x 40 mm  
**064-032-04**

4 Zähne  
4 teeth  
4 dientes  
4 denti

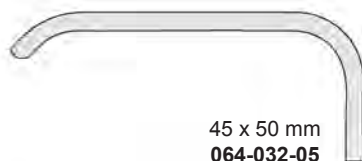

45 x 50 mm  
**064-032-05**

5 Zähne  
5 teeth  
5 dientes  
5 denti

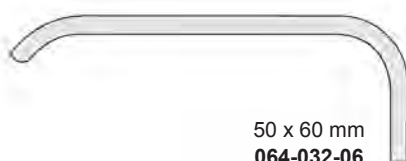

50 x 60 mm  
**064-032-06**

6 Zähne  
6 teeth  
6 dientes  
6 denti



70 x 70 mm  
**064-032-07**

6 Zähne  
6 teeth  
6 dientes  
6 denti



**LANGENBECK**  
22,0 cm, 8<sup>5</sup>/<sub>8</sub>"



30 x 11 mm  
**064-110-30**



30 x 14 mm  
**064-110-31**



30 x 16 mm  
**064-110-32**



40 x 11 mm  
**064-110-40**



50 x 11 mm  
**064-110-50**



**LANGENBECK**  
22,0 cm, 8<sup>5</sup>/<sub>8</sub>"



30 x 11 mm  
**064-120-30**



30 x 14 mm  
**064-120-31**



30 x 16 mm  
**064-120-32**



40 x 11 mm  
**064-120-40**



50 x 11 mm  
**064-120-50**



**KOCHER-LANGENBECK**  
21,5 cm, 8½"



22 x 6 mm  
**064-130-22**



25 x 6 mm  
**064-130-25**



25 x 8 mm  
**064-130-26**



35 x 8 mm  
**064-130-35**



35 x 11 mm  
**064-130-36**



35 x 15 mm  
**064-130-37**



40 x 11 mm  
**064-130-40**



70 x 14 mm  
**064-130-70**



80 x 12 mm  
**064-130-80**

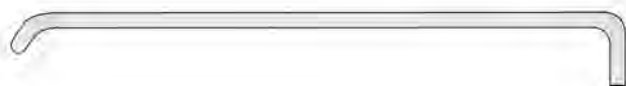

80 x 16 mm  
**064-130-85**

Wundhaken  
Retractors  
Separadores  
Divaricatori



**KOCHER**  
23,0 cm, 9"



40 x 18 mm  
**064-140-18**



60 x 20 mm  
**064-140-20**



60 x 25 mm  
**064-140-25**



75 x 30 mm  
**064-140-30**



75 x 40 mm  
**064-140-40**



**SAUERBRUCH**  
22,5 cm, 8<sup>3</sup>/<sub>4</sub>"



44 x 16 mm  
**064-150-44**



55 x 22 mm  
**064-150-55**



72 x 19 mm  
**064-150-72**



**MIDDELDORPF**



21,5 cm, 8<sup>1</sup>/<sub>2</sub>"  
14 x 17 mm  
**064-180-01**



22,0 cm, 8<sup>5</sup>/<sub>8</sub>"  
20 x 22 mm  
**064-180-02**



23,5 cm, 9<sup>1</sup>/<sub>4</sub>"  
26 x 30 mm  
**064-180-03**



**MIDDELDORPF**



21,5 cm, 8<sup>1</sup>/<sub>2</sub>"  
14 x 17 mm  
**064-182-01**



22,0 cm, 8<sup>5</sup>/<sub>8</sub>"  
20 x 22 mm  
**064-182-02**



23,5 cm, 9<sup>1</sup>/<sub>4</sub>"  
26 x 30 mm  
**064-182-03**



**RICHARDSON (KELLY)**  
24,0 cm, 9<sup>1</sup>/<sub>2</sub>"



28 x 20 mm  
**064-210-02**



36 x 28 mm  
**064-210-03**

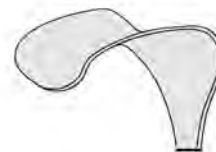

44 x 38 mm  
**064-210-04**



52 x 22 mm  
**064-210-05**

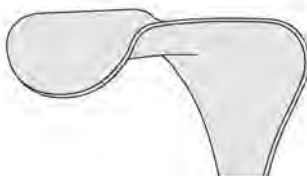

65 x 50 mm  
**064-210-06**

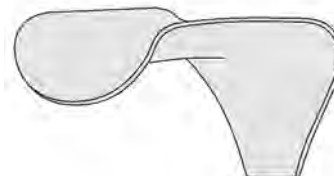

70 x 65 mm  
**064-210-07**

**Wundhaken  
Retractors  
Separadores  
Divaricatori**

49 x 38 mm

28 x 20 mm

Fig. 2

Fig. 1

36 x 28 mm

63 x 49 mm

**RICHARDSON-EASTMAN**

Fig. 1+2	28,0 cm, 11"	<b>062-200-00</b>
Fig. 1	26,0 cm, 10 <sup>1</sup> / <sub>4</sub> "	<b>062-200-01</b>
Fig. 2	28,0 cm, 11"	<b>062-200-02</b>



**PENTAX**  
SURGICAL



**MIDDELDORPF**  
25,5 cm, 10"



40 x 45 mm	<b>064-192-01</b>
45 x 50 mm	<b>064-192-02</b>
55 x 70 mm	<b>064-192-03</b>



**FRITSCH**  
24,0 cm, 9<sup>1</sup>/<sub>2</sub>"



45 x 40 mm	<b>064-240-40</b>
45 x 50 mm	<b>064-240-50</b>
45 x 60 mm	<b>064-240-60</b>
55 x 75 mm	<b>064-240-75</b>
65 x 85 mm	<b>064-240-85</b>



**DOYEN**  
25,0 cm, 10"  
**064-230-50**



120 x 52 mm  
064-220-01

105 x 30 mm  
064-220-02

90 x 28 mm  
064-220-03

**DOYEN-STILLE**  
22,0 cm, 8<sup>5</sup>/<sub>6</sub>"



70 x 25 mm	064-250-70
80 x 42 mm	064-250-81
80 x 50 mm	064-250-82
80 x 60 mm	064-250-83

**KOCHER**  
25,0 cm, 10"

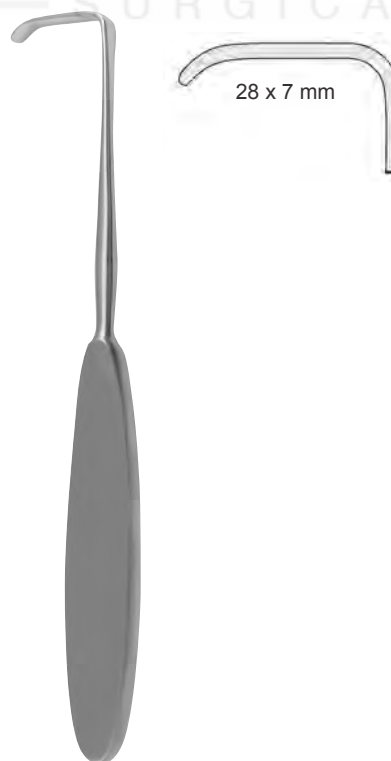

28 x 7 mm

**LAHEY**  
19,0 cm, 7<sup>1</sup>/<sub>2</sub>"  
061-160-19

Wundhaken  
Retractors  
Separadores  
Divaricatori



**LITTLE**  
20,0 cm, 8"  
064-164-20



12 x 13 mm



**SIMON**

28,0 cm, 11"

115 x 22 mm **064-260-01**  
115 x 27 mm **064-260-02**



**KELLY**  
27,0 cm, 10<sup>1</sup>/<sub>2</sub>"

160 x 38 mm **064-280-61**  
160 x 57 mm **064-280-62**  
190 x 38 mm **064-280-91**  
190 x 57 mm **064-280-92**

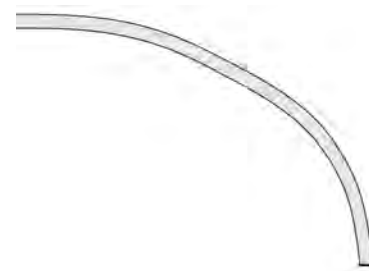
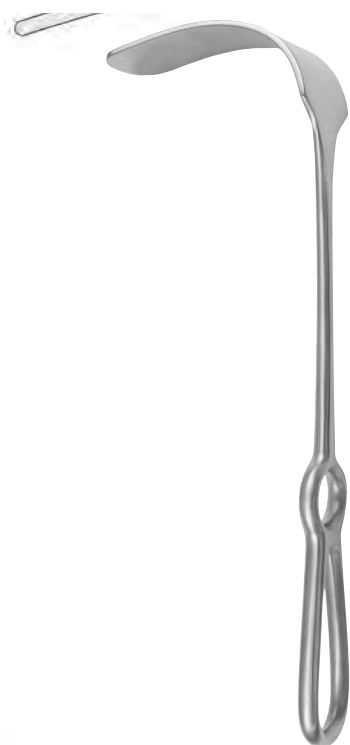

85 x 35 mm	<b>064-274-01</b>
120 x 50 mm	<b>064-274-02</b>
150 x 50 mm	<b>064-274-03</b>

**MIKULICZ**  
26,0 cm, 10<sup>1</sup>/<sub>4</sub>"



90 x 50 mm

**MIKULICZ**  
26,0 cm, 10<sup>1</sup>/<sub>4</sub>"  
**064-272-90**

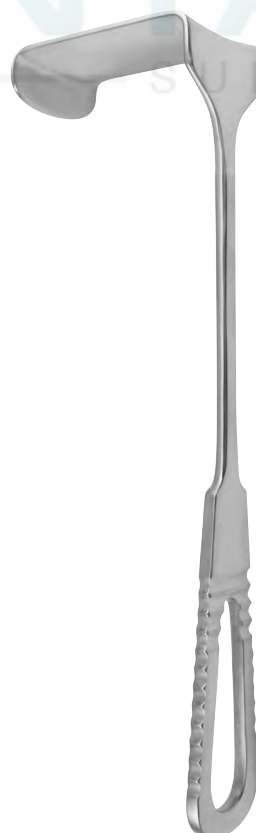

70 x 38 mm	<b>064-290-38</b>
70 x 50 mm	<b>064-290-51</b>

**MORRIS**  
24,5 cm, 9<sup>5</sup>/<sub>8</sub>"

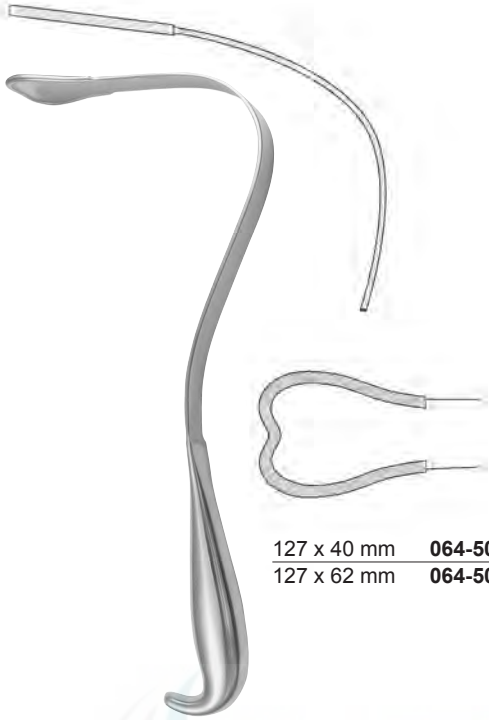

127 x 40 mm **064-500-40**  
127 x 62 mm **064-500-62**

**HARRINGTON**  
32,0 cm, 12<sup>1</sup>/<sub>2</sub>"



82 x 22 mm **064-390-01**  
108 x 43 mm **064-390-02**  
115 x 65 mm **064-390-03**

**CORYKKOS**  
24,0 cm, 9<sup>1</sup>/<sub>2</sub>"

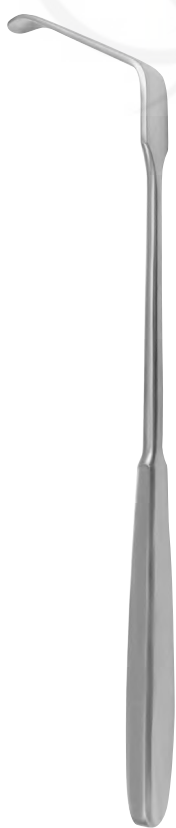

**ZENKER**

75 x 12 mm

60 x 12 mm

35 x 8 mm

25,0 cm, 9<sup>3</sup>/<sub>4</sub>"  
**064-320-25**

26,0 cm, 10<sup>1</sup>/<sub>4</sub>"  
**064-320-26**

27,5 cm, 10<sup>3</sup>/<sub>4</sub>"  
**064-320-27**



**MEYERDING**  
22,5 cm, 8<sup>3</sup>/<sub>4</sub>"

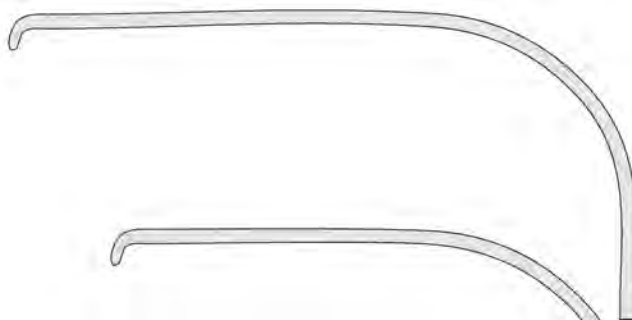

90 x 50 mm  
**064-350-50**

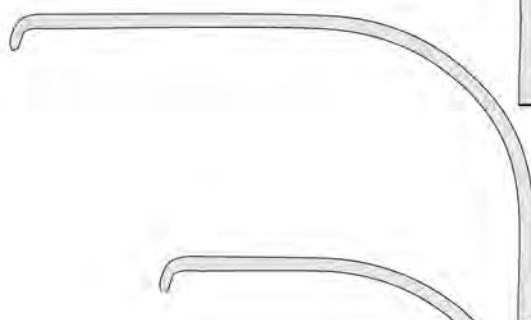

75 x 25 mm  
**064-350-25**



50 x 16 mm  
**064-350-16**



**BRUNNER**  
25,0 cm, 10"



180 x 30 mm  
**064-360-18**



160 x 30 mm  
**064-360-16**



140 x 25 mm  
**064-360-14**



120 x 25 mm  
**064-360-12**



100 x 20 mm  
**064-360-10**

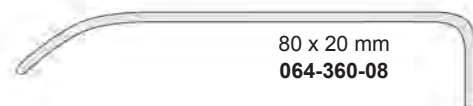

80 x 20 mm  
**064-360-08**

Wundhaken  
Retractors  
Separadores  
Divaricatori

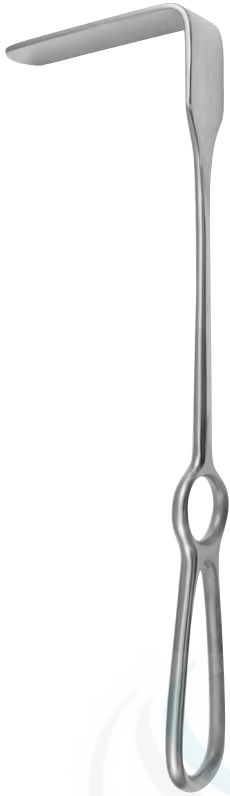

**BRUNNER**  
25,0 cm, 10"



180 x 30 mm  
**064-370-18**



160 x 30 mm  
**064-370-16**



140 x 25 mm  
**064-370-14**



120 x 25 mm  
**064-370-12**



100 x 20 mm  
**064-370-10**

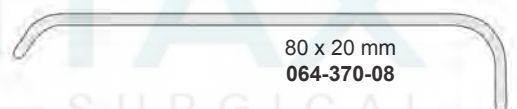

80 x 20 mm  
**064-370-08**



19 mm

**DEAVER**  
18,0 cm, 7"  
**064-602-18**



22 mm

**DEAVER**  
21,5 cm, 8½"  
**064-602-22**



25 mm

**DEAVER**  
23,0 cm, 9"  
**064-602-23**



**DEAVER**  
30,0 cm, 11<sup>3</sup>/<sub>4</sub>"  
064-604-30



**DEAVER**  
33,0 cm, 13"  
064-604-33

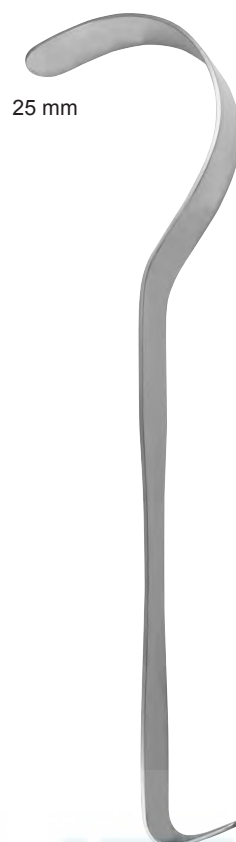

**DEAVER**  
36,0 cm, 14<sup>1</sup>/<sub>8</sub>"  
064-604-36



**DEAVER**  
30,0 cm, 11<sup>3</sup>/<sub>4</sub>"  
064-610-38



**DEAVER**  
30,0 cm, 11<sup>3</sup>/<sub>4</sub>"  
064-610-50



**DEAVER**  
30,0 cm, 11<sup>3</sup>/<sub>4</sub>"  
064-610-75

Wundhaken  
Retractors  
Separadores  
Divaricatori



25 mm	<b>064-600-25</b>
38 mm	<b>064-600-38</b>
50 mm	<b>064-600-50</b>
75 mm	<b>064-600-75</b>

**DEAVER**  
30,0 cm, 11<sup>3</sup>/<sub>4</sub>"



40 mm	30,0 cm, 11 <sup>3</sup> / <sub>4</sub> "	<b>064-700-30</b>
54 mm	32,0 cm, 12 <sup>1</sup> / <sub>2</sub> "	<b>064-700-32</b>

**ALLISON**



75 x 50 mm	16,0 cm, 6 <sup>1</sup> / <sub>4</sub> "	<b>064-710-50</b>
75 x 90 mm	16,0 cm, 6 <sup>1</sup> / <sub>4</sub> "	<b>064-710-90</b>

**DAVIDSON**



**ST MARKS**

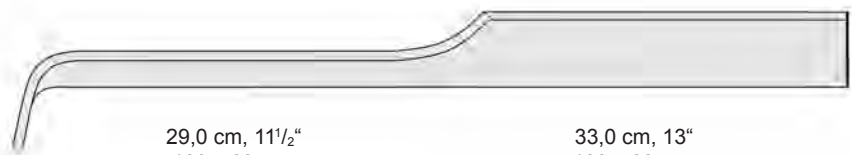

29,0 cm, 11<sup>1</sup>/<sub>2</sub>"  
130 x 60 mm  
**064-720-01**

33,0 cm, 13"  
180 x 60 mm  
**064-720-02**



29,0 cm, 11<sup>1</sup>/<sub>2</sub>"  
130 x 60 mm  
**064-721-01**

33,0 cm, 13"  
180 x 60 mm  
**064-721-02**

**Wundspreizer**  
**Self-Retaining Retractors**  
**Separadores con retenida automática**  
**Divaricatori autostatici**

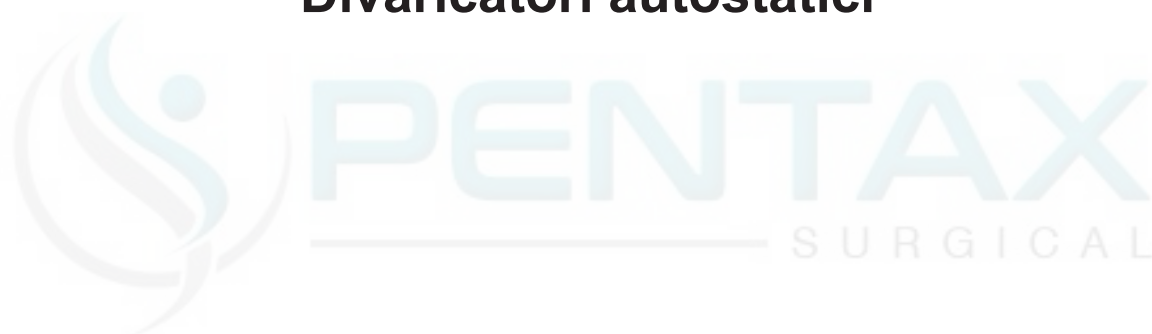

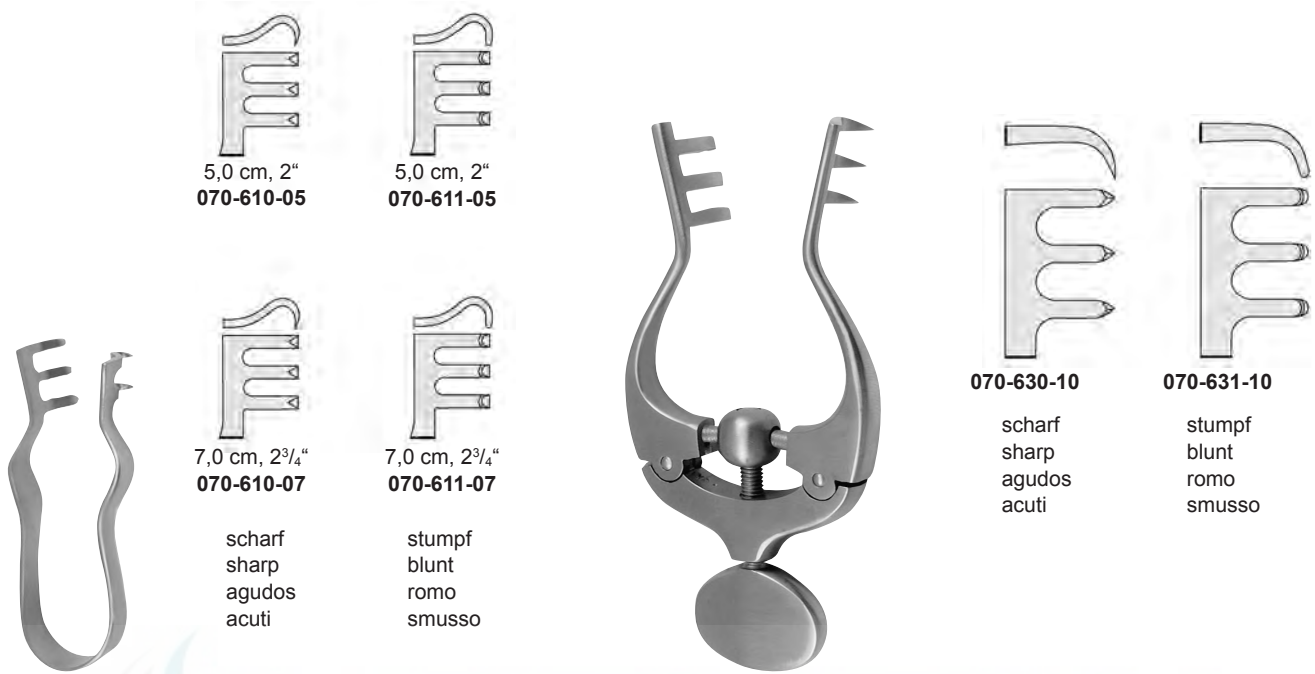

5,0 cm, 2"  
 070-610-05

5,0 cm, 2"  
 070-611-05

7,0 cm, 2<sup>3</sup>/<sub>4</sub>"  
 070-610-07

7,0 cm, 2<sup>3</sup>/<sub>4</sub>"  
 070-611-07

scharf  
 sharp  
 agudos  
 acuti

stumpf  
 blunt  
 romo  
 smusso

070-630-10  
 scharf  
 sharp  
 agudos  
 acuti

070-631-10  
 stumpf  
 blunt  
 romo  
 smusso

FINSEN

JANSEN  
 10,0 cm, 4"

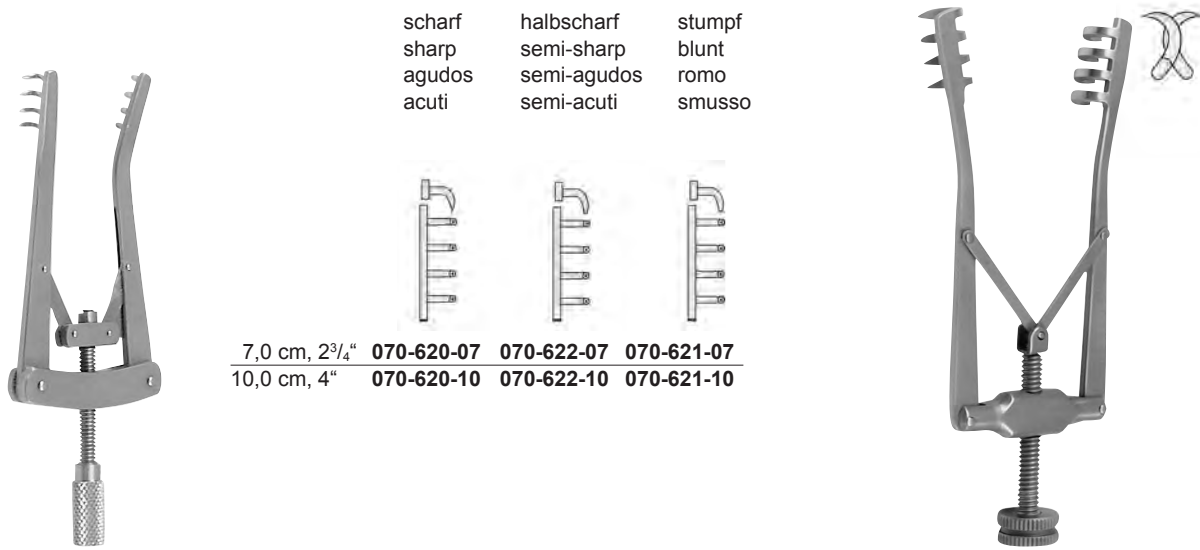

scharf      halbscharf      stumpf  
 sharp      semi-sharp      blunt  
 agudos      semi-agudos      romo  
 acuti      semi-acuti      smusso

7,0 cm, 2<sup>3</sup>/<sub>4</sub>"    070-620-07    070-622-07    070-621-07  
 10,0 cm, 4"    070-620-10    070-622-10    070-621-10

ALM

ALLPORT  
 9,5 cm, 3<sup>3</sup>/<sub>4</sub>"  
 070-626-09

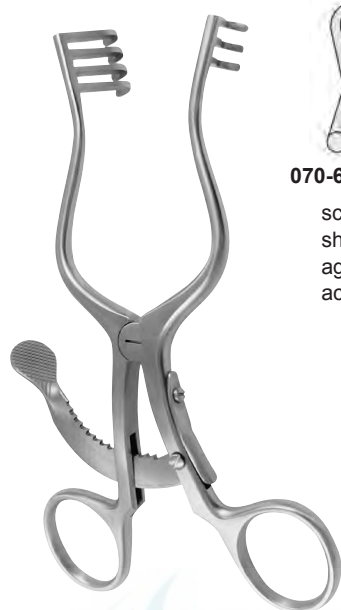

**SALP-CONTOUR**  
14,0 cm, 5½"



**ADSON-BABY**  
16,0 cm, 6¼"

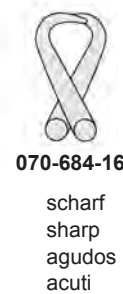

**ANDERSON-ADSON**  
19,0 cm, 8"

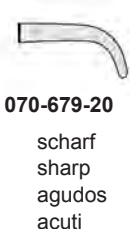

**ADSON**  
26,5 cm, 10½"

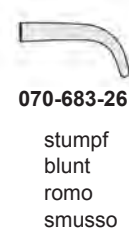
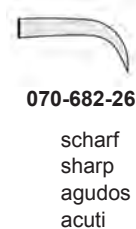

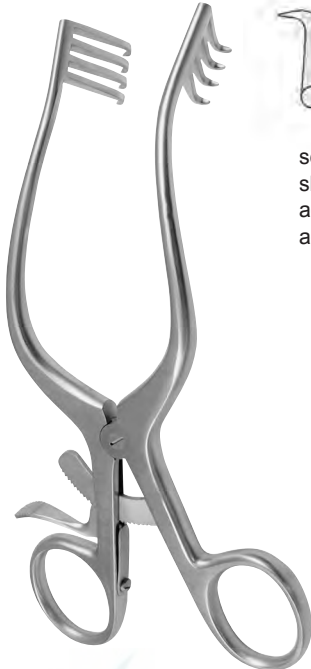

**MOLLISON**  
 15,5 cm, 6"  
 070-674-15



scharf  
 sharp  
 agudos  
 acuti



**SCHUHKNECHT**  
 12,5 cm, 5"



070-800-12  
 scharf  
 sharp  
 agudos  
 acuti



070-801-12  
 stumpf  
 blunt  
 romo  
 smuss

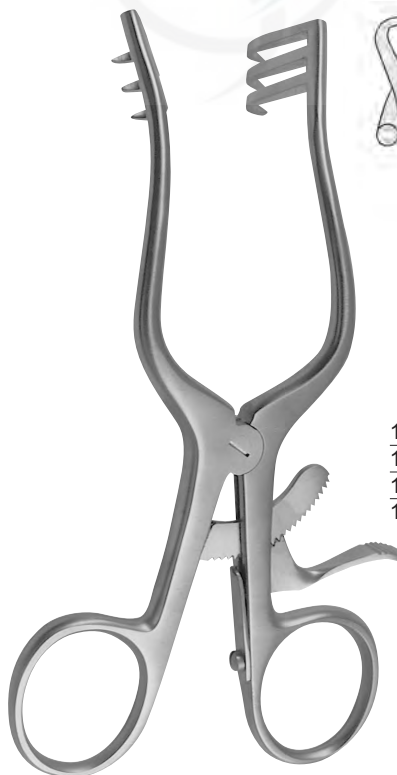

**WULLSTEIN**



scharf  
 sharp  
 agudos  
 acuti

stumpf  
 blunt  
 romo  
 smusso

10,5 cm, 4 <sup>1</sup> / <sub>8</sub> "	070-810-10	070-811-10
13,0 cm, 5"	070-810-13	070-811-13
15,0 cm, 6"	070-810-15	070-811-15
18,0 cm, 7"	070-810-18	070-811-18



**MAYO-ADAMS**  
 16,5 cm, 6<sup>1</sup>/<sub>2</sub>"  
 070-822-17

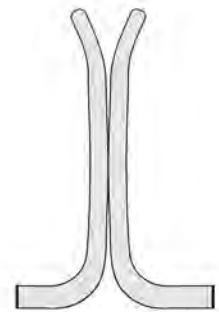

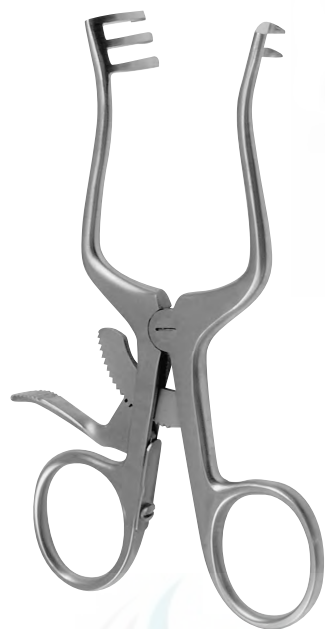

**WEITLANER-LOKTITE**  
10,5 cm, 4 1/8"



**070-650-10**

scharf  
sharp  
agudos  
acuti



**070-651-10**

stumpf  
blunt  
romo  
smusso

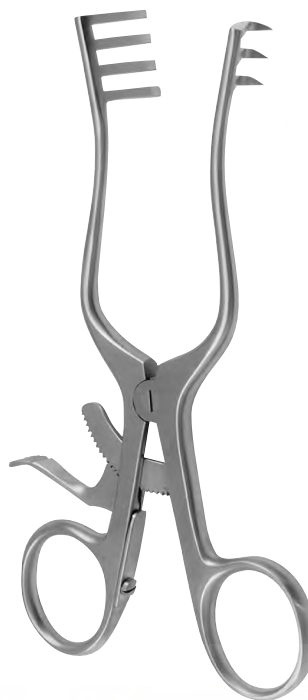

**WEITLANER**  
13,0 cm, 5"



**070-670-13**

scharf  
sharp  
agudos  
acuti



**070-671-13**

stumpf  
blunt  
romo  
smusso



**WEITLANER**  
16,5 cm, 6 1/2"



**070-670-16**

scharf  
sharp  
agudos  
acuti



**070-671-16**

stumpf  
blunt  
romo  
smusso



**WEITLANER**  
20,0 cm, 8"



**070-670-20**

scharf  
sharp  
agudos  
acuti



**070-671-20**

stumpf  
blunt  
romo  
smusso



**WEITLANER**  
 24,0 cm, 9 1/2"



**070-670-24**

scharf  
 sharp  
 agudos  
 acuti



**070-671-24**

stumpf  
 blunt  
 romo  
 smusso



**PLESTER**  
 13,0 cm, 5"



**070-830-13**

scharf  
 sharp  
 agudos  
 acuti



**070-831-13**

stumpf  
 blunt  
 romo  
 smusso



**MILLIGAN**  
 13,0 cm, 5"  
 070-840-13

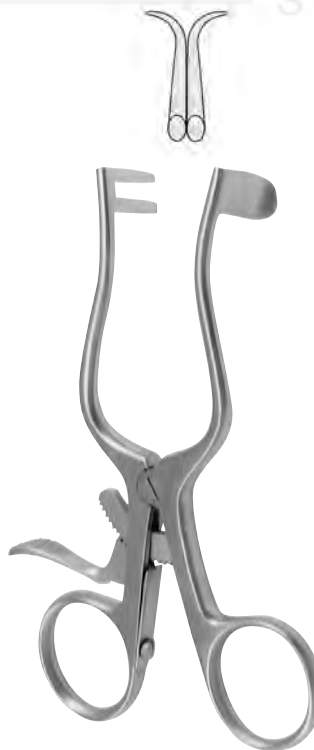
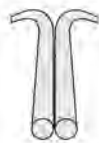

**PLESTER**  
 11,0 cm, 4 3/8"  
 070-672-11

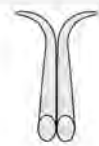

**PLESTER**  
 11,0 cm, 4 3/8"  
 070-673-11



**WEITLANER-BABY**  
13,0 cm, 5"  
070-850-13

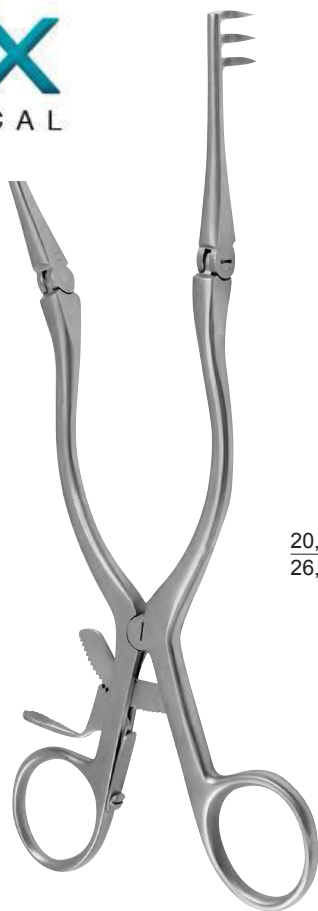

**ADSON  
(CONE)**

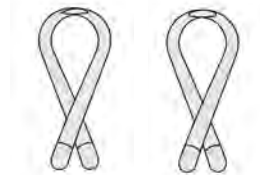

20,0 cm, 8"    **070-860-20**    **070-861-20**  
26,0 cm, 10<sup>1</sup>/<sub>4</sub>"    **070-860-26**    **070-861-26**

scharf	stumpf
sharp	blunt
agudos	romo
acuti	smusso

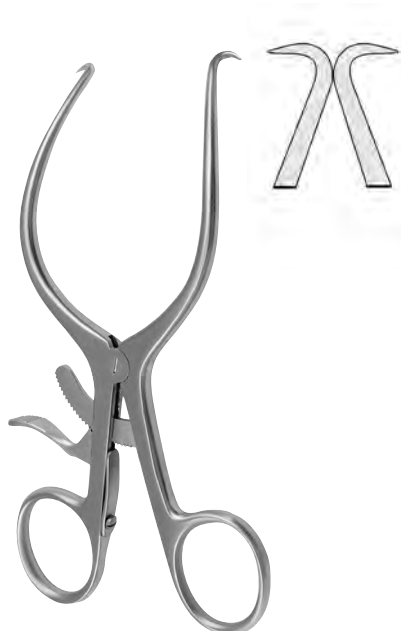

**GELPI**  
13,5 cm, 5<sup>3</sup>/<sub>8</sub>"  
070-202-14



**GELPI**  
19,0 cm, 7<sup>1</sup>/<sub>2</sub>"  
070-202-19



**GELPI-LOKTITE**  
18,0 cm, 7<sup>1</sup>/<sub>2</sub>"  
070-250-19

Wundspreizer  
 Self-Retaining Retractors  
 Separadores con retenida automática  
 Divaricatori autostatici

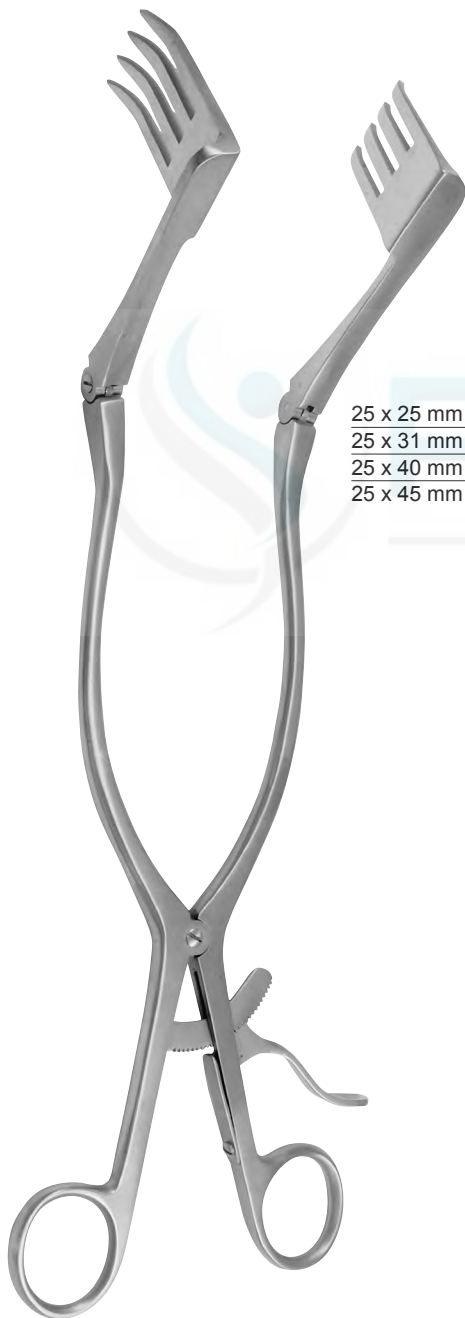

**BECKMANN-ADSON**  
 31,0 cm, 12 1/4"

25 x 25 mm	<b>070-870-01</b>	<b>070-871-01</b>
25 x 31 mm	<b>070-870-02</b>	<b>070-871-02</b>
25 x 40 mm	<b>070-870-03</b>	<b>070-871-03</b>
25 x 45 mm	<b>070-870-04</b>	<b>070-871-04</b>

scharf	stumpf
sharp	blunt
agudos	romo
acuti	smusso

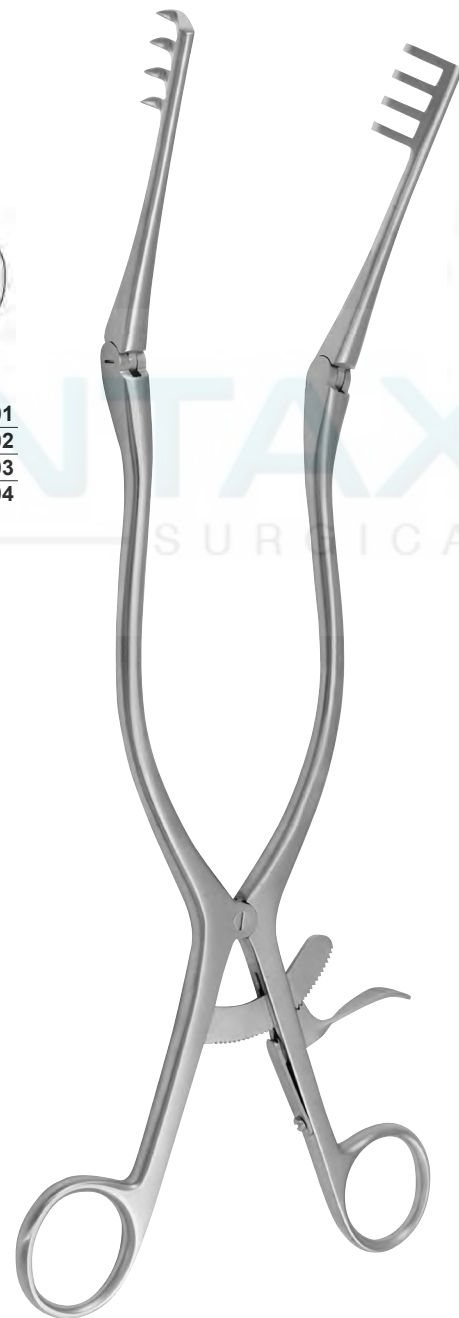

**BECKMANN**  
 31,0 cm, 12 1/4"



**070-690-31**  
 scharf  
 sharp  
 agudos  
 acuti



070-691-32

stumpf  
blunt  
romo  
smusso

**BECKMANN**  
32,0 cm, 12½"



**DE BAKEY**

10,0 cm, 4"    070-240-10  
14,0 cm, 5½"    070-240-14

Wundspreizer  
 Self-Retaining Retractors  
 Separadores con retenida automática  
 Divaricatori autostatici



stumpf  
 blunt  
 romo  
 smusso

**NORFOLK AND NORWICH**  
 22,0 cm, 8<sup>5</sup>/<sub>8</sub>"  
 070-401-22



stumpf  
 blunt  
 romo  
 smusso

**JACKSON BURROWS**  
 17,5 cm, 7"  
 070-411-17



**RICHTER**  
 17,0 cm, 6<sup>3</sup>/<sub>4</sub>"  
 070-420-17



**JOLL (FRIEDMAN)**  
 15,5 cm, 6"  
 070-430-15

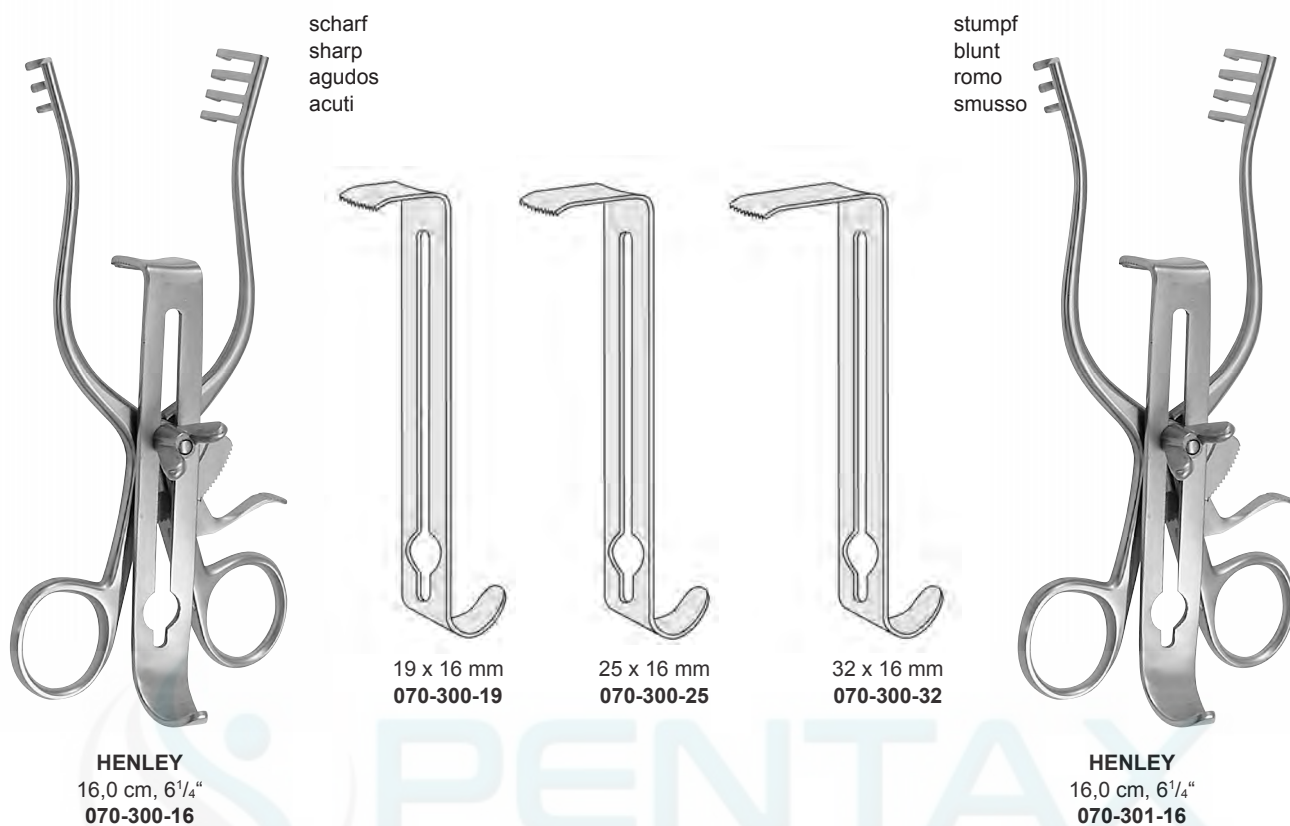

**HENLEY**  
070-300-00

komplett, bestehend aus:

- 1 Sperrer mit Seitenvalven, scharf (30-1300-16)
- 1 Mittelvalve 19 x 16 mm (30-1300-19)
- 1 Mittelvalve 25 x 16 mm (30-1300-25)
- 1 Mittelvalve 32 x 16 mm (30-1300-32)

complete, consisting of:

- 1 Spreader with lateral valves, sharp (30-1300-16)
- 1 Central valve 19 x 16 mm (30-1300-19)
- 1 Central valve 25 x 16 mm (30-1300-25)
- 1 Central valve 32 x 16 mm (30-1300-32)

completo, compuesto of:

- 1 Separador con valvas laterales, agudas (30-1300-16)
- 1 Valva central 19 x 16 mm (30-1300-19)
- 1 Valva central 25 x 16 mm (30-1300-25)
- 1 Valva central 32 x 16 mm (30-1300-32)

completo, composto da:

- 1 Divaricatore con valve laterali, acuto (30-1300-16)
- 1 Valva centrale 19 x 16 mm (30-1300-19)
- 1 Valva centrale 25 x 16 mm (30-1300-25)
- 1 Valva centrale 32 x 16 mm (30-1300-32)

**HENLEY**  
070-301-00

komplett, bestehend aus:

- 1 Sperrer mit Seitenvalven, stumpf (30-1301-16)
- 1 Mittelvalve 19 x 16 mm (30-1300-19)
- 1 Mittelvalve 25 x 16 mm (30-1300-25)
- 1 Mittelvalve 32 x 16 mm (30-1300-32)

complete, consisting of:

- 1 Spreader with lateral valves, blunt (30-1301-16)
- 1 Central valve 19 x 16 mm (30-1300-19)
- 1 Central valve 25 x 16 mm (30-1300-25)
- 1 Central valve 32 x 16 mm (30-1300-32)

completo, compuesto of:

- 1 Separador con valvas laterales, romas (30-1301-16)
- 1 Valva central 19 x 16 mm (30-1300-19)
- 1 Valva central 25 x 16 mm (30-1300-25)
- 1 Valva central 32 x 16 mm (30-1300-32)

completo, composto da:

- 1 Divaricatore con valve laterali, smusso (30-1301-16)
- 1 Valva centrale 19 x 16 mm (30-1300-19)
- 1 Valva centrale 25 x 16 mm (30-1300-25)
- 1 Valva centrale 32 x 16 mm (30-1300-32)

Wundspreizer, Bauchdeckenhalter  
 Self-Retaining Retractors, Abdominal Retractors  
 Separadores con retenida automática, Separadores abdominales  
 Divaricatori autostatici, Divaricatori addominali



**MAYO-ADAMS**  
 17,0 cm, 6<sup>3</sup>/<sub>4</sub>"  
 070-320-17



**COLLIN-BABY**  
 18,0 cm, 7"  
 070-330-18

80 mm  
 30 x 44 mm  
 070-330-30

Wechselvalven  
 Exchangeable blades  
 Valvas intergambiabiles  
 Valve intercambiabili



23 x 44 mm  
 070-330-23

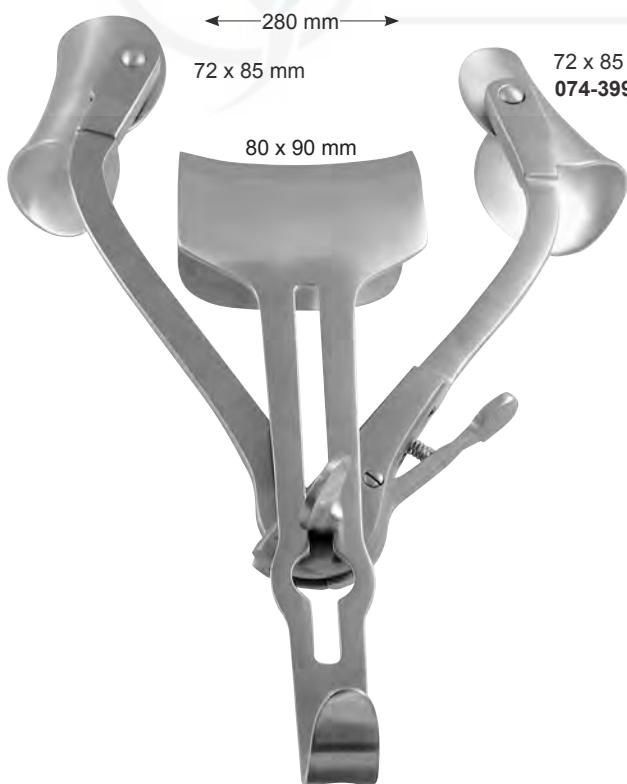

**RICARD**  
 28,0 cm, 11"  
 074-310-28

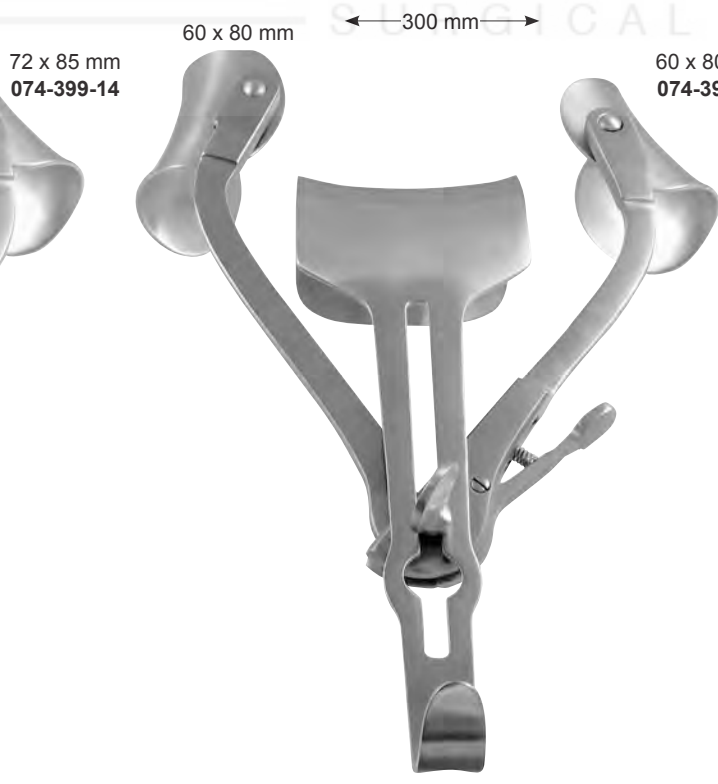

**RICARD**  
 30,0 cm, 12"  
 074-312-30

38 x 62 mm  
 074-398-10

← 135-160 mm →



**COLLIN**  
 23,5 cm, 9 1/4"  
 074-330-24

← 135-160 mm →



**COLLIN**  
 23,5 cm, 9 1/4"  
 074-332-24

60 x 80 mm  
 074-398-13

← 135-160 mm →



**COLLIN**  
 23,5 cm, 9 1/4"  
 074-334-24

Wundspreizer, Bauchdeckenhalter  
 Self-Retaining Retractors, Abdominal Retractors  
 Separadores con retenida automática, Separadores abdominales  
 Divaricatori autostatici, Divaricatori addominali



38 x 62 mm **074-399-01**  
 40 x 80 mm **074-399-02**  
 60 x 80 mm **074-399-03**



50 x 58 mm **074-399-10**  
 60 x 80 mm **074-399-13**  
 72 x 85 mm **074-399-14**



**074-399-23**  
 60 x 80 mm



**074-399-33**  
 60 x 80 mm



58 x 50 mm **074-398-01**  
 80 x 60 mm **074-398-02**  
 85 x 72 mm **074-398-03**



62 x 38 mm **074-398-10**  
 80 x 38 mm **074-398-11**  
 100 x 38 mm **074-398-12**  
 80 x 38 mm **074-398-13**



**COLLIN**  
 55 x 55 mm **074-331-01**  
 55 x 65 mm **074-331-02**  
 55 x 75 mm **074-331-03**

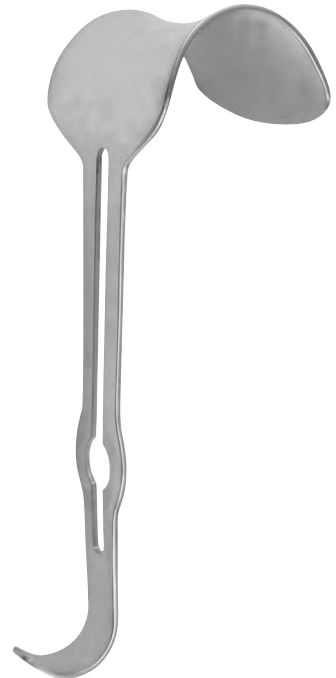

**RICARD**  
 65 x 50 mm **074-310-01**  
 70 x 55 mm **074-310-02**  
 90 x 80 mm **074-310-03**

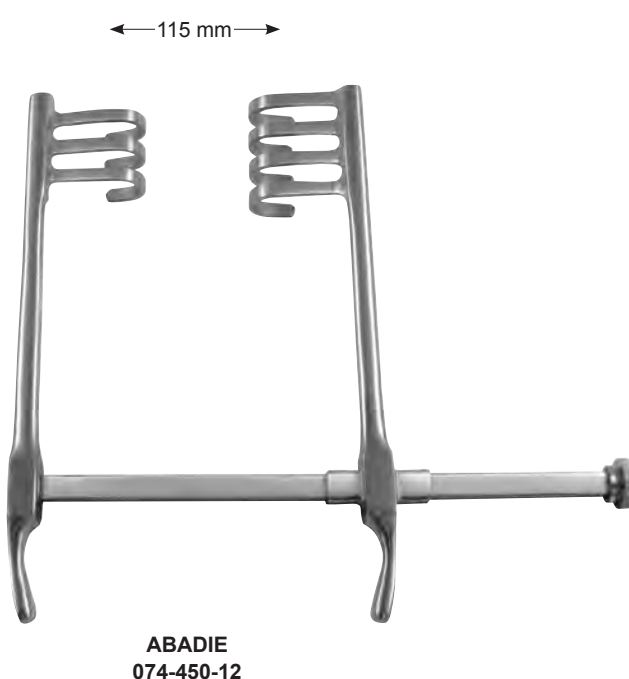
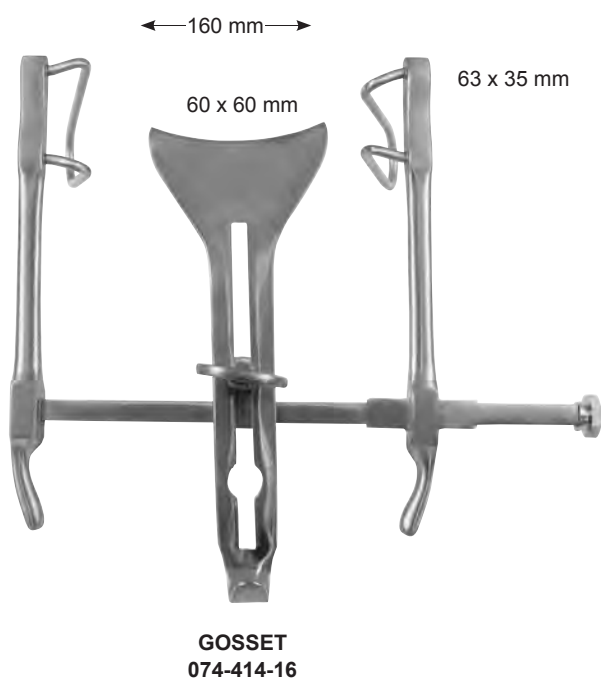
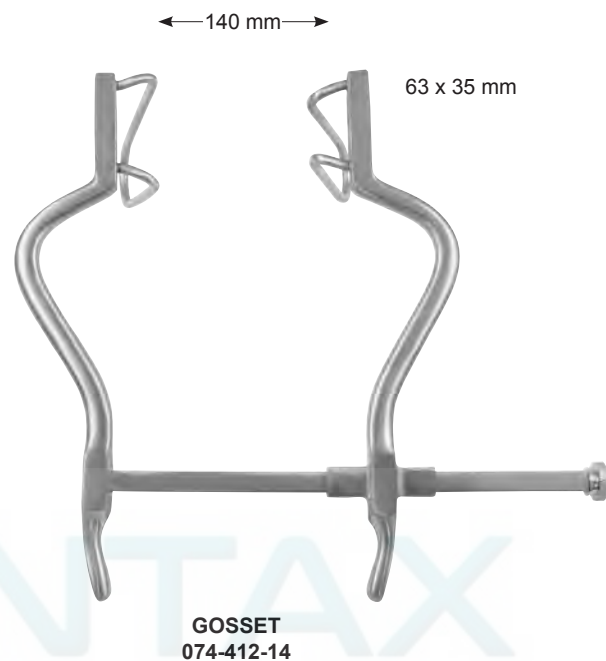
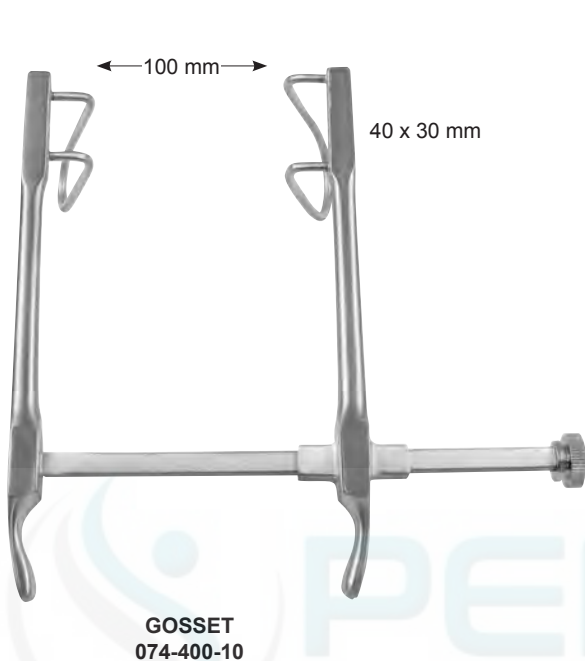

Bauchdeckenhalter  
 Abdominal Retractors  
 Separadores abdominales  
 Divaricatori addominali



**BALFOUR**  
 074-764-18



**BALFOUR**  
 074-768-20

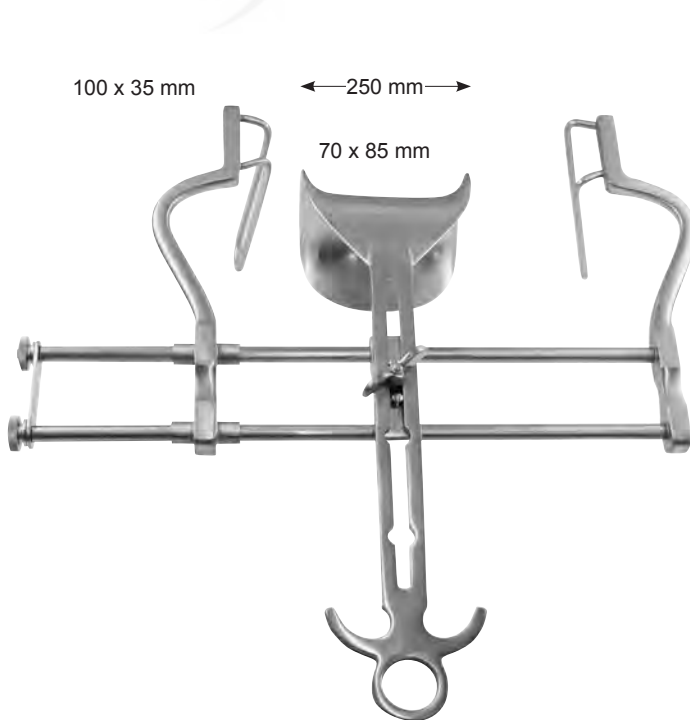

**BALFOUR**  
 074-768-25

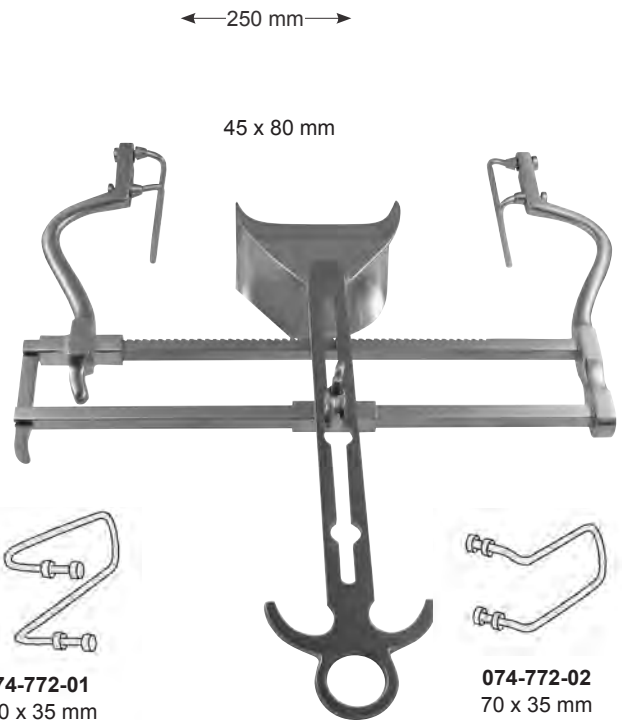

**BALFOUR US-TYPE**  
 074-772-25

**074-772-01**  
 100 x 35 mm

**074-772-02**  
 70 x 35 mm

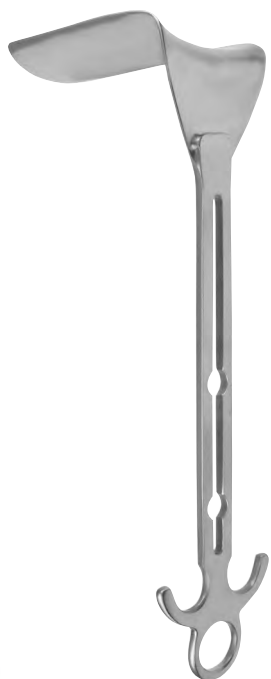

**BALFOUR**  
100 x 70 mm  
074-799-70

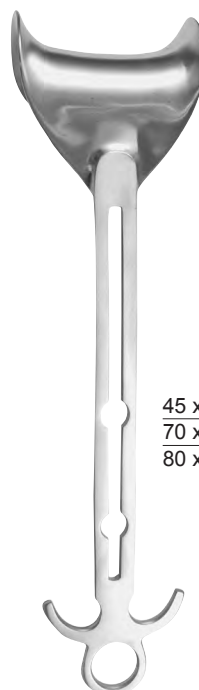

45 x 80 mm **074-798-01**  
70 x 85 mm **074-798-02**  
80 x 90 mm **074-798-03**

**BALFOUR**

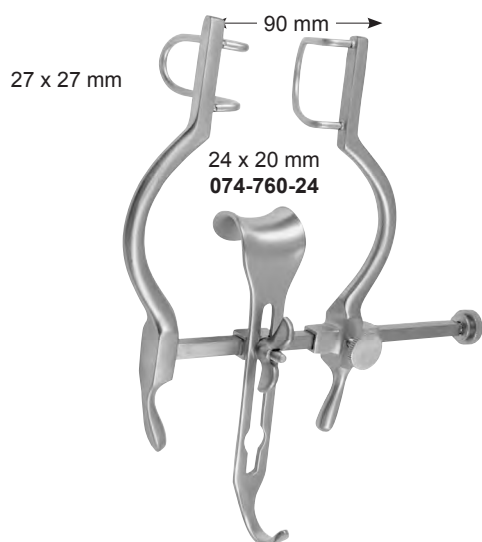

**BALFOUR**  
074-760-09

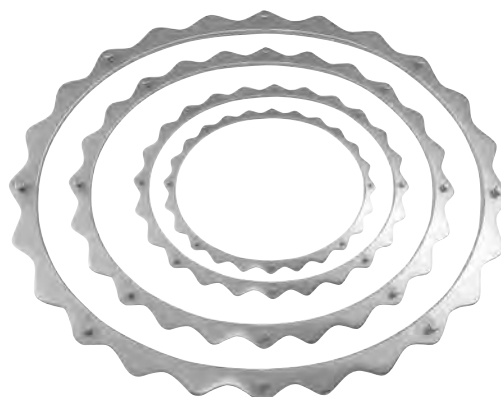

Ø 180 mm, 7" **074-850-18**  
Ø 230 mm, 9" **074-850-23**  
Ø 305 mm, 12" **074-850-30**  
455 x 330 mm **074-850-45**

geschwärzt, black finish, negra, nera;



**074-859-02**  
51 x 38 mm



**074-859-03**  
70 x 60 mm



**074-859-05**  
114 x 60 mm

geschwärzt, black finish, negra, nera



**074-859-06**  
19 x 76 mm



**074-859-07**  
38 x 102 mm



**074-859-08**  
57 x 89 mm



**074-859-09**  
57 x 114 mm

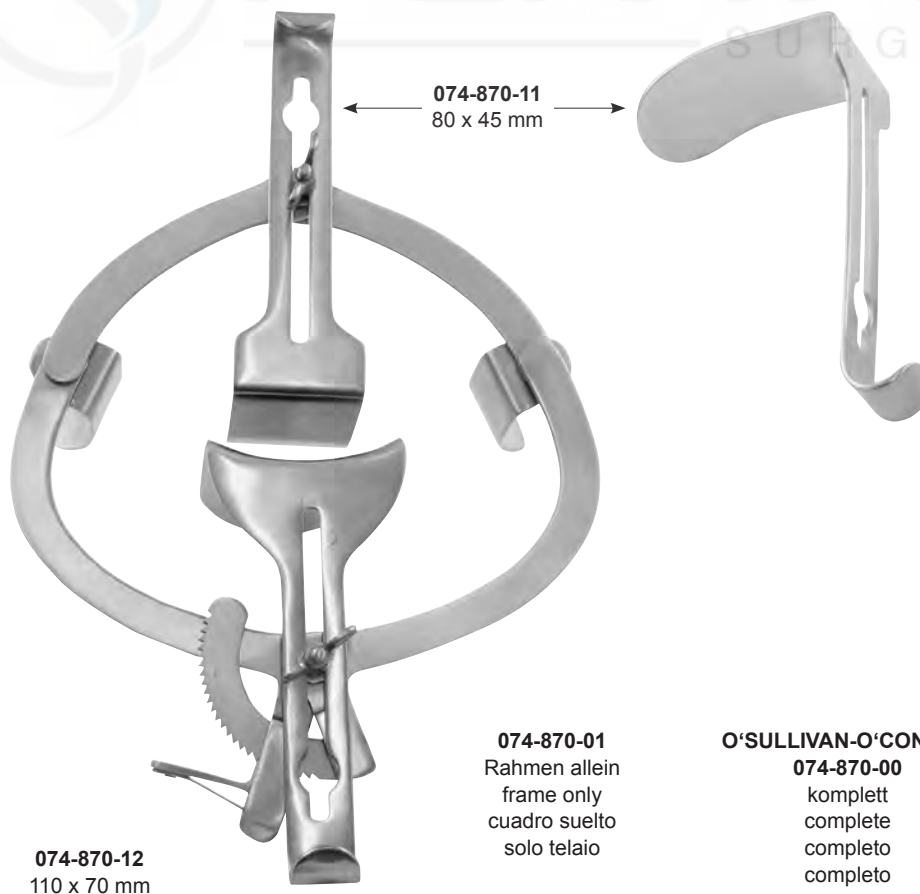
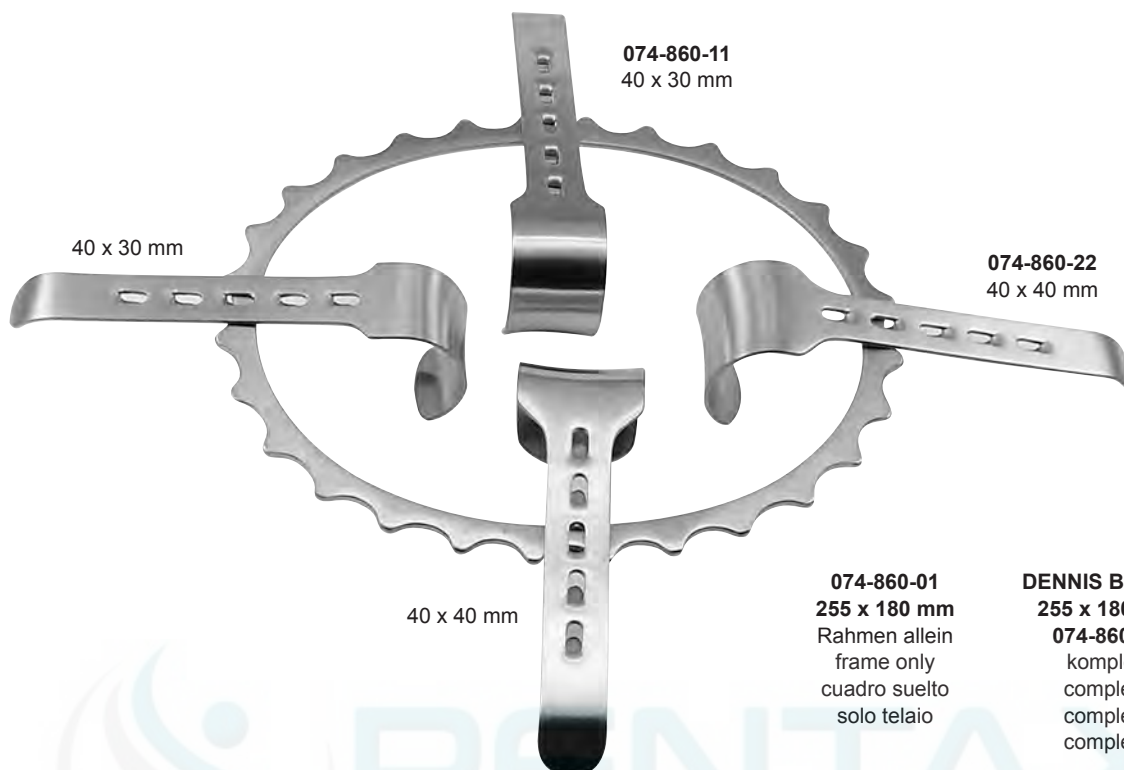

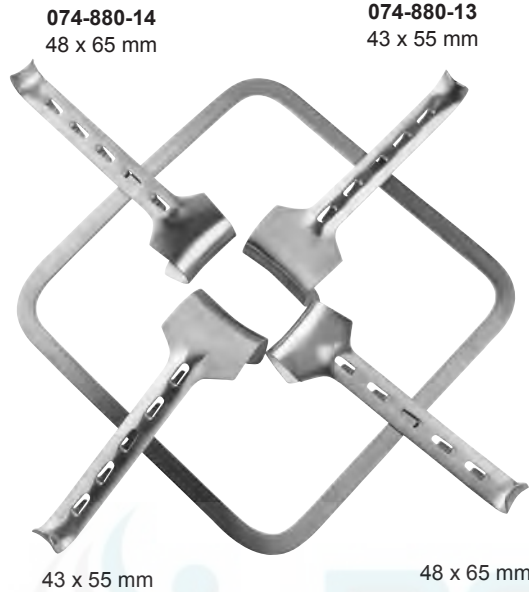

**074-880-14**  
48 x 65 mm

**074-880-13**  
43 x 55 mm

43 x 55 mm

48 x 65 mm

**074-880-01** 250 x 250 mm  
**074-880-02** 300 x 320 mm  
**074-880-03** 300 x 380 mm  
Rahmen allein  
frame only  
cuadro suelto  
solo telaio

**KIRSCHNER**  
**074-880-00**  
komplett  
complete  
completo  
completo  
1 x 31-1880-01  
2 x 31-1880-13  
2 x 31-1880-14

**074-882-01**  
255 x 255 mm  
zusammenlegbarer Rahmen, allein  
folding frame, only  
cuadro plegable, suelto  
telaio pieghevole, solo

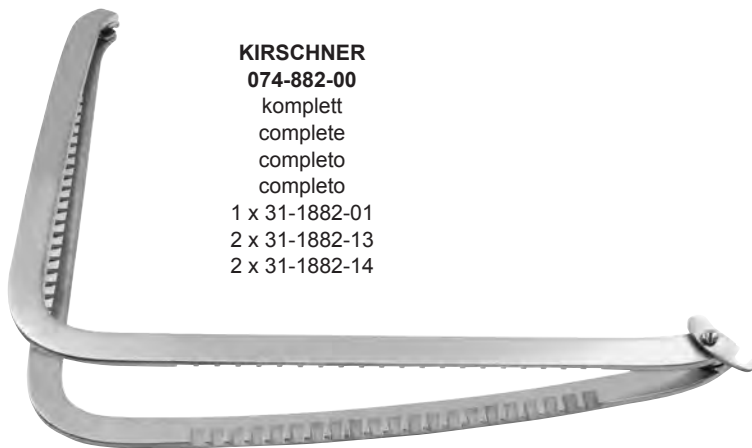

**KIRSCHNER**  
**074-882-00**  
komplett  
complete  
completo  
completo  
1 x 31-1882-01  
2 x 31-1882-13  
2 x 31-1882-14



43 x 55 mm **074-880-13**  
48 x 65 mm **074-880-14**  
80 x 90 mm **074-880-15**  
90 x 65 mm **074-880-16**  
98 x 95 mm **074-880-17**

**KIRSCHNER**



**KIRSCHNER**  
60 x 82 mm  
**074-880-11**



**KIRSCHNER-BALFOUR**  
83 x 82 mm  
**074-880-12**



**KIRSCHNER**  
98 x 51 mm **074-880-20**  
105 x 38 mm **074-880-21**

**PENTAX**  
SURGICAL

**074-880-14**  
48 x 65 mm

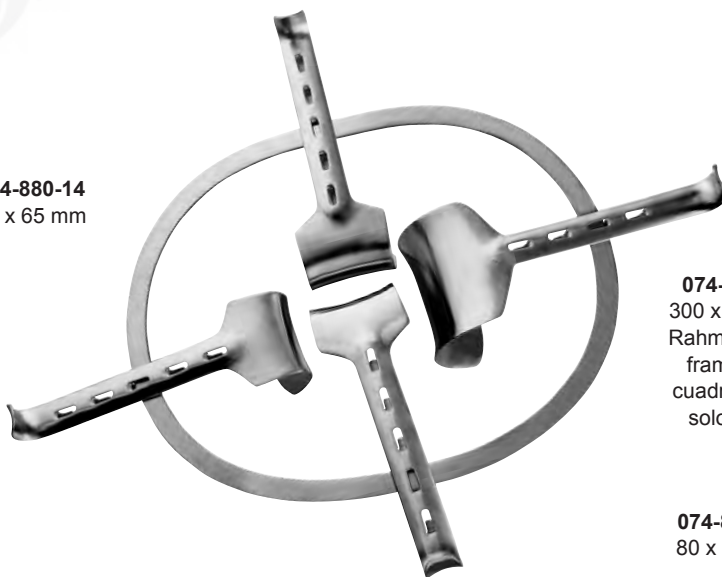

**074-890-00**  
300 x 240 mm  
Rahmen allein  
frame only  
cuadro suelto  
solo telaio

**074-880-15**  
80 x 90 mm

**KIRSCHNER, oval**  
**074-884-00**

komplett, complete, completo, comple to

1 x 31-1884-01

3 x 31-1884-14

1 x 31-1884-15

1 x 31-1884-20

1 x 31-1884-21

Bauchdeckenhalter  
 Abdominal Retractors  
 Separadores abdominales  
 Divaricatori addominali

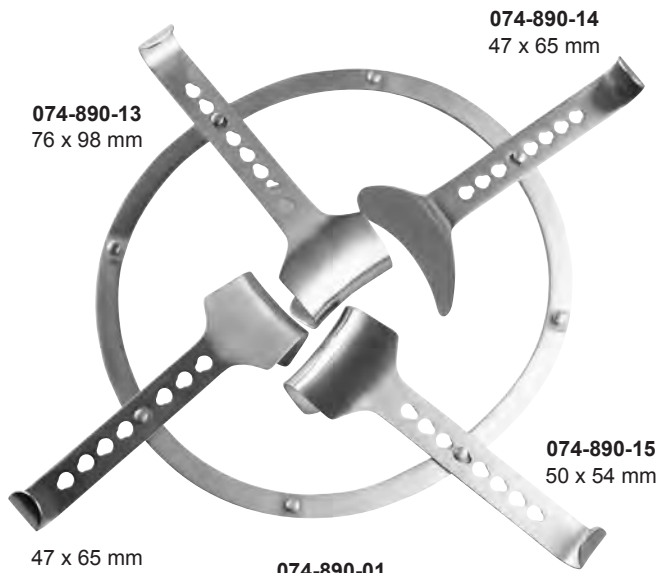

**074-890-13**  
76 x 98 mm

**074-890-14**  
47 x 65 mm

47 x 65 mm

**074-890-15**  
50 x 54 mm



**074-890-11**  
98 x 52 mm

**074-890-12**  
105 x 35 mm

**074-890-01**  
275 x 250 mm  
Rahmen allein  
frame only  
cuadro suelto  
solo telaio



**074-900-01**  
300 x 300 mm  
zusammenlegbarer Rahmen, allein  
folding frame, only  
cuadro plegable, suelto  
telaio pieghevole, solo

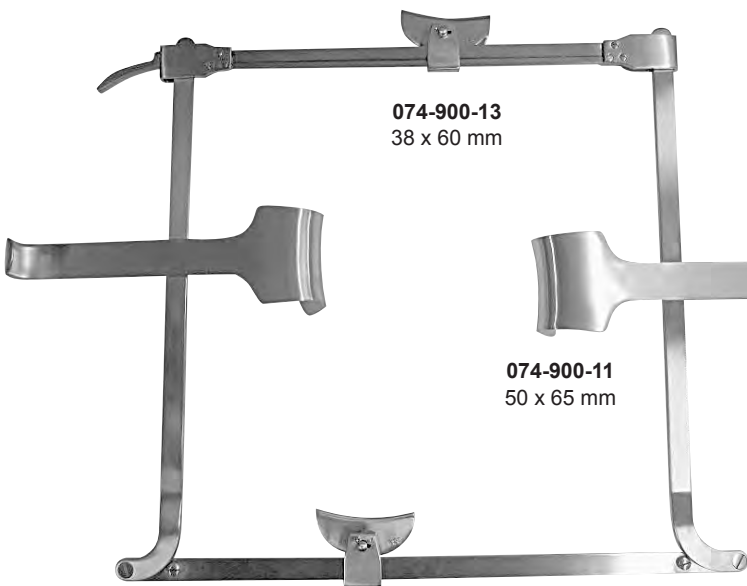

**074-900-13**  
38 x 60 mm

**074-900-11**  
50 x 65 mm



38 x 60 mm **074-900-13**  
45 x 80 mm **074-900-14**

50 x 65 mm **074-900-11**  
60 x 85 mm **074-900-12**

**FRANZ**  
**074-900-00**  
komplett  
complete  
completo  
completo  
1 x 31-1900-01

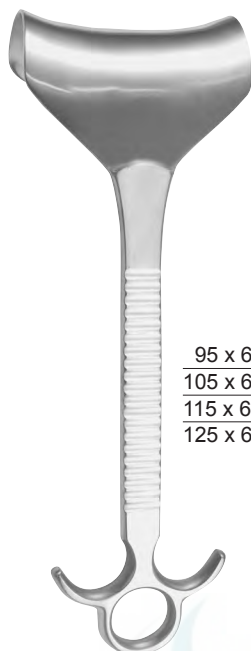

**DOYEN**  
28,0 cm, 11"

95 x 60 mm **074-910-11**  
105 x 65 mm **074-910-12**  
115 x 65 mm **074-910-13**  
125 x 65 mm **074-910-14**

für / for / para / per  
074-910-11  
074-910-14

Kette mit Gewicht  
Chain with weight  
Catena con pesa  
Catena con peso

53,0 cm, 21"

66,0 cm, 26"

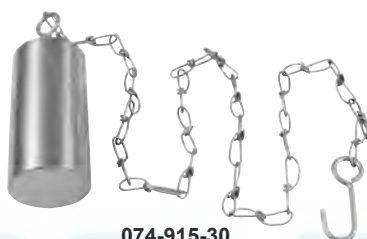

**074-915-30**  
78,5 cm, 31"

Befestigungsgestell  
Mounting frame  
Bastidor para la fijación  
Telaio di supporto per il fissaggio

**ROCHARD**  
**074-920-01**

PENTAX  
SURGICAL

53,0 cm, 21"

66,0 cm, 26"

Befestigungsgestell  
Mounting frame  
Bastidor para la fijación  
Telaio di supporto per il fissaggio

**ROCHARD**  
**074-920-02**



**ROCHARD**  
28,0 cm, 11"  
**074-920-20**

95 x 48 mm **074-920-10**  
105 x 48 mm **074-920-12**  
115 x 48 mm **074-920-12**  
125 x 48 mm **074-920-13**  
155 x 48 mm **074-920-16**

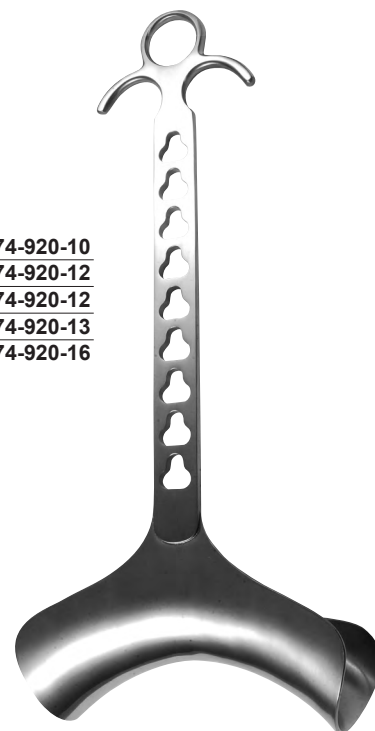

**ROCHARD**  
28,0 cm, 11"

Bauchspatel  
Abdominal Spatulas  
Espátulas abdominales  
Spatole addominali



biegsam  
malleable  
maleable  
malleabile

200 x 6 mm **078-210-06**  
200 x 12 mm **078-210-12**  
200 x 17 mm **078-210-17**  
200 x 20 mm **078-210-20**  
200 x 25 mm **078-210-25**

**RIBBON**



biegsam  
malleable  
maleable  
malleabile

330 x 13 mm **078-170-13**  
330 x 25 mm **078-170-25**  
330 x 32 mm **078-170-32**  
330 x 40 mm **078-170-40**  
330 x 50 mm **078-170-50**

**RIBBON**



biegsam  
malleable  
maleable  
malleabile

280 x 25/30 mm **078-200-01**  
300 x 37/45 mm **078-200-02**  
300 x 40/50 mm **078-200-03**

**RIBBON**



biegsam  
malleable  
maleable  
malleabile

**TUFFIER**  
200 x 25/17 mm  
**078-220-20**



**REVERDIN**  
280 x 45/60 mm  
**078-230-28**

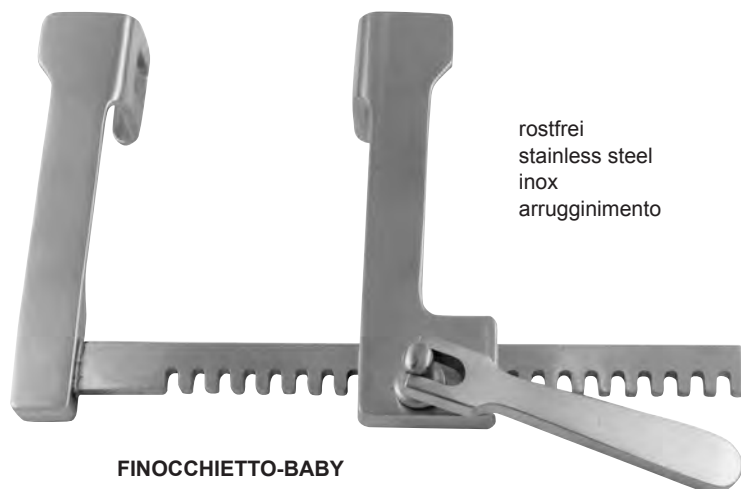

**FINOCCHIETTO-BABY**

a	b	c	
18 mm	20 mm	75 mm	<b>140-100-01</b>

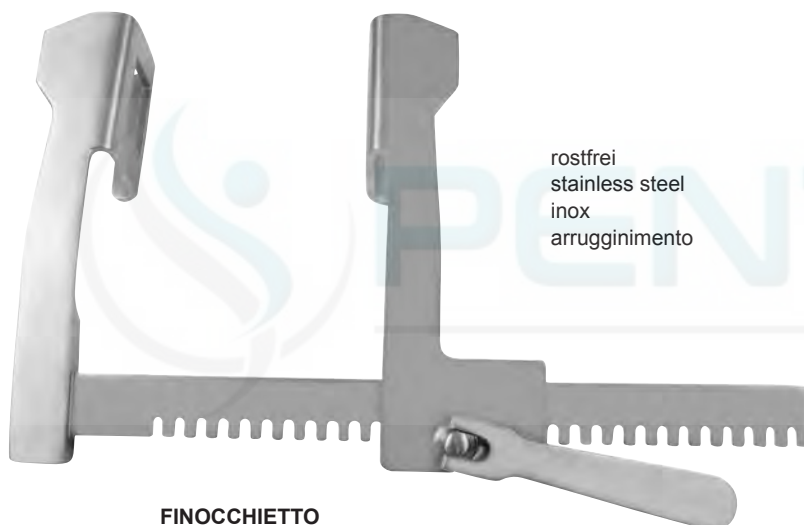

**FINOCCHIETTO**

a	b	c	
40 mm	40 mm	165 mm	<b>140-100-02</b>
45 mm	65 mm	200 mm	<b>140-100-03</b>
70 mm	65 mm	250 mm	<b>140-100-04</b>

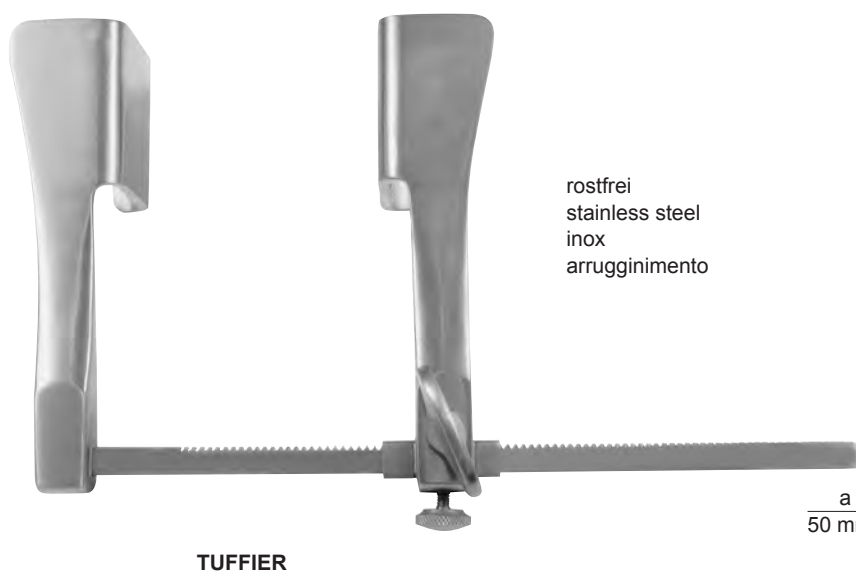

**TUFFIER**

a	b	c	
50 mm	45 mm	165 mm	<b>140-150-01</b>

**Sonden, Trokare  
Probes, Trocars  
Sondas, Trócares  
Sonde, Trequarti**

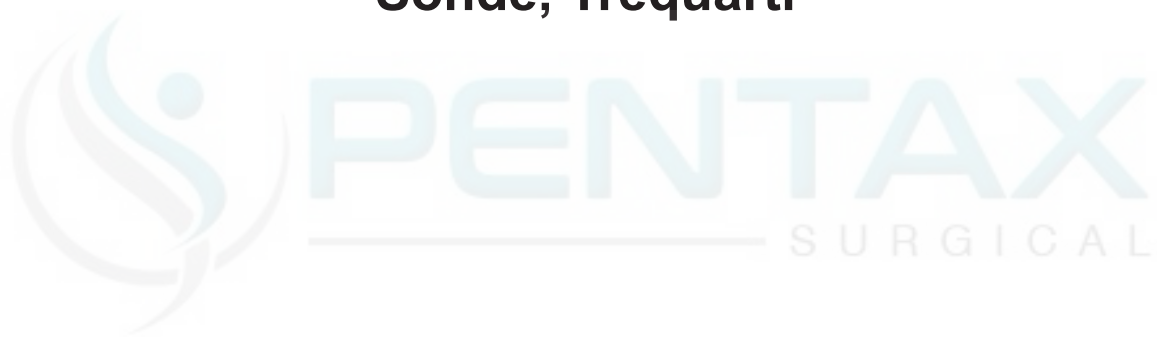

Sonden  
Probes  
Sondas  
Sonde



	Ø 1,0 mm	Ø 2,0 mm
11,5 cm, 4 <sup>1</sup> / <sub>2</sub> "	<b>080-000-11</b>	<b>080-004-11</b>
13,0 cm, 5"	<b>080-000-13</b>	<b>080-004-13</b>
14,5 cm, 5 <sup>3</sup> / <sub>4</sub> "	<b>080-000-14</b>	<b>080-004-14</b>
16,0 cm, 6 <sup>1</sup> / <sub>4</sub> "	<b>080-000-16</b>	<b>080-004-15</b>
18,0 cm, 7"	<b>080-000-18</b>	<b>080-004-18</b>
20,0 cm, 8"	<b>080-000-20</b>	<b>080-004-20</b>

Ø 2,0 mm



11,5 cm, 4 <sup>1</sup> / <sub>2</sub> "	<b>080-013-11</b>
13,0 cm, 5"	<b>080-013-13</b>
14,5 cm, 5 <sup>3</sup> / <sub>4</sub> "	<b>080-013-14</b>
16,0 cm, 6 <sup>1</sup> / <sub>4</sub> "	<b>080-013-16</b>
18,0 cm, 7"	<b>080-013-18</b>
20,0 cm, 8"	<b>080-013-20</b>

Ø 1,0 mm



Silber  
Silver  
Plata  
Argento

**STACKE**  
10,5 cm, 4<sup>1</sup>/<sub>8</sub>"  
**080-033-10**



Myrtenblattsonden  
Myrtle leaf probes  
Sondas para mirto  
Sonde a foglia di mirto

11,5 cm, 4 <sup>1</sup> / <sub>2</sub> "	<b>080-027-11</b>
13,0 cm, 5"	<b>080-027-13</b>
14,5 cm, 5 <sup>3</sup> / <sub>4</sub> "	<b>080-027-14</b>
16,0 cm, 6 <sup>1</sup> / <sub>4</sub> "	<b>080-027-16</b>
18,0 cm, 7"	<b>080-027-18</b>
20,0 cm, 8"	<b>080-027-20</b>



**NÉLATON**  
16,0 cm, 6<sup>1</sup>/<sub>4</sub>"  
**080-120-16**



**DOYEN**  
14,5 cm, 5<sup>3</sup>/<sub>4</sub>"  
**080-117-14**



**BRODIE**  
20,0 cm, 8"  
**080-126-20**

Ø 3,5 mm

Ø 3,5 mm



11,5 cm, 4 1/2"	<b>080-110-11</b>
13,0 cm, 5"	<b>080-110-13</b>
14,5 cm, 5 3/4"	<b>080-110-14</b>
16,0 cm, 6 1/4"	<b>080-110-16</b>
18,0 cm, 7"	<b>080-110-18</b>
20,0 cm, 8"	<b>080-110-20</b>

Ø 3,3 mm



13,0 cm, 5"	<b>080-122-13</b>
14,5 cm, 5 3/4"	<b>080-122-14</b>
16,0 cm, 6 1/4"	<b>080-122-16</b>
18,0 cm, 7"	<b>080-122-18</b>



**PENTAX**  
SURGICAL



**LOCKHART-MUMMERY**  
16,5 cm, 6 1/2"  
**080-130-01**



**LOCKHART-MUMMERY**  
16,5 cm, 6 1/2"  
**080-130-02**

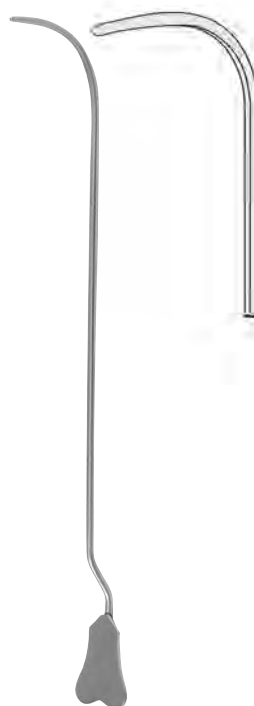

**LOCKHART-MUMMERY**  
16,5 cm, 6 1/2"  
**080-130-03**

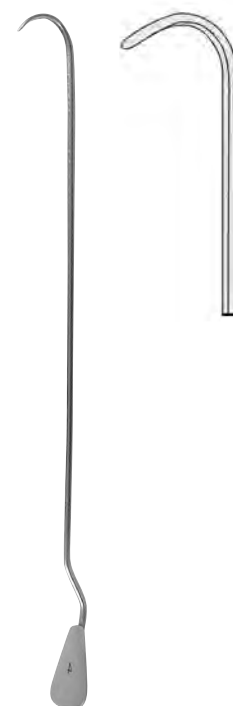

**LOCKHART-MUMMERY**  
16,5 cm, 6 1/2"  
**080-130-04**

Watteträger  
 Cotton Applicators  
 Porta-algodones  
 Porta-cotone

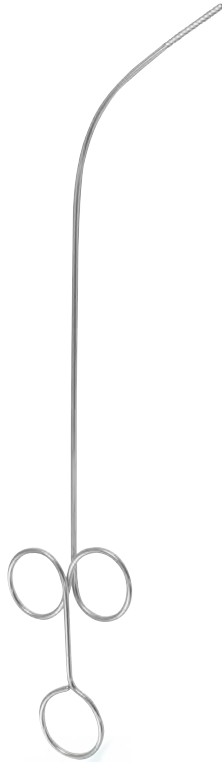

**FEIN**  
 28,0 cm, 11"  
 080-264-28



**UKERMANN**  
 16,0 cm, 6 1/4"  
 080-260-16

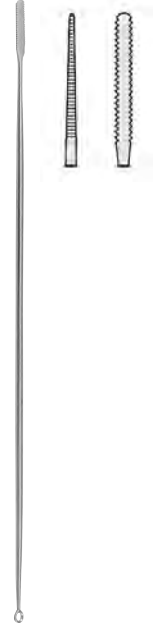

**JOBSON-HORNE**  
 18,0 cm, 7"  
 080-262-18



12,0 cm, 4 3/4" **080-271-12** Ø 0,9 mm  
 14,0 cm, 5 3/4" **080-271-14** Ø 0,9 mm  
 16,5 cm, 6 1/4" **080-271-16** Ø 1,1 mm  
 18,0 cm, 7" **080-271-18** Ø 1,2 mm

**FARRELL**  
 (LATHBURY)



12,0 cm, 4 3/4" **080-270-12** Ø 0,9 mm  
 14,0 cm, 5 3/4" **080-270-14** Ø 0,9 mm  
 16,5 cm, 6 1/4" **080-270-16** Ø 1,1 mm  
 18,0 cm, 7" **080-270-18** Ø 1,2 mm

**FARRELL**



**080-150-01**  
Metalletui  
Metal case  
Estuche de metal  
Scatola in metallo  
135 x 100 x 25 mm



Ø 3,0 mm  
**080-150-03**



Ø 6,0 mm  
**080-150-06**

**NABATOFF**  
**080-150-00**  
komplett  
complete  
completo  
completo



Ø 9,0 mm  
**080-150-09**



**080-150-21**  
Zugseil  
Cable  
Cable  
Fune



Ø 12,0 mm  
**080-150-12**

**080-150-22**  
Kunststoff-Sondenspitze  
Plastic probe tip  
Extremidad de sonda de plástico  
Punta in materia plastica

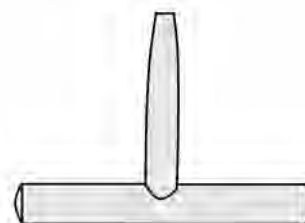

**080-150-20**  
Handgriff  
Handle  
Mango  
Manico



**STANDARD**  
11,0 cm, 4<sup>3</sup>/<sub>8</sub>"

Ø 3,0 mm	<b>084-110-30</b>
Ø 3,5 mm	<b>084-110-35</b>
Ø 4,0 mm	<b>084-110-40</b>
Ø 4,5 mm	<b>084-110-45</b>
Ø 5,0 mm	<b>084-110-50</b>
Ø 5,5 mm	<b>084-110-55</b>
Ø 6,0 mm	<b>084-110-60</b>



**STANDARD**  
12,0 cm, 4<sup>3</sup>/<sub>4</sub>"

Ø 3,0 mm	<b>084-112-30</b>
Ø 3,5 mm	<b>084-112-35</b>
Ø 4,0 mm	<b>084-112-40</b>
Ø 4,5 mm	<b>084-112-45</b>
Ø 5,0 mm	<b>084-112-50</b>
Ø 5,5 mm	<b>084-112-55</b>
Ø 6,0 mm	<b>084-112-60</b>



**STANDARD**  
12,0 cm, 4<sup>3</sup>/<sub>4</sub>"

Ø 3,0 mm	<b>084-114-30</b>
Ø 3,5 mm	<b>084-114-35</b>
Ø 4,0 mm	<b>084-114-40</b>
Ø 4,5 mm	<b>084-114-45</b>
Ø 5,0 mm	<b>084-114-50</b>
Ø 5,5 mm	<b>084-114-55</b>
Ø 6,0 mm	<b>084-114-60</b>



**HURWITZ**

Ø 7,3 mm	<b>084-118-07</b>
Ø 8,7 mm	<b>084-118-09</b>
Ø 12,0 mm	<b>084-118-12</b>



UNIVERSAL  
084-100-03

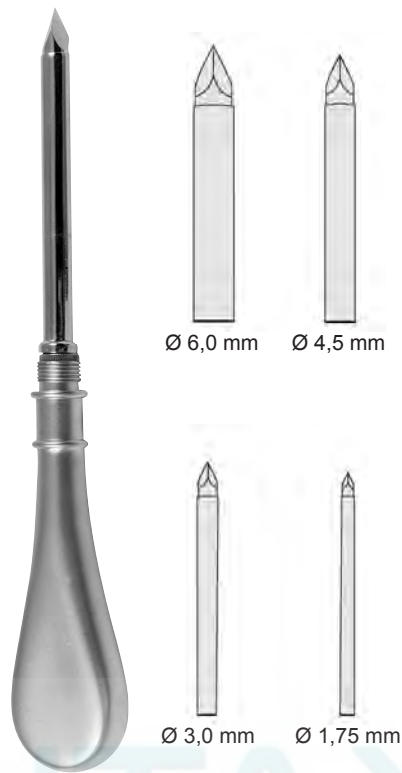

UNIVERSAL  
084-100-04

140 mm

LANDAU  
Ø 2,0 mm  
084-160-16

LANDAU  
Ø 2,0 mm  
084-161-16

DAVIDSON  
Ø 6,0 mm  
084-164-18

BUELAU  
Ø 8,0 mm  
084-124-24

Trokare  
Trocars  
Trócares  
Trequarti



Ø 6,0 mm    **084-128-06**  
Ø 8,0 mm    **084-128-08**

**CAMPBELL**  
16,0 cm, 6 1/4"

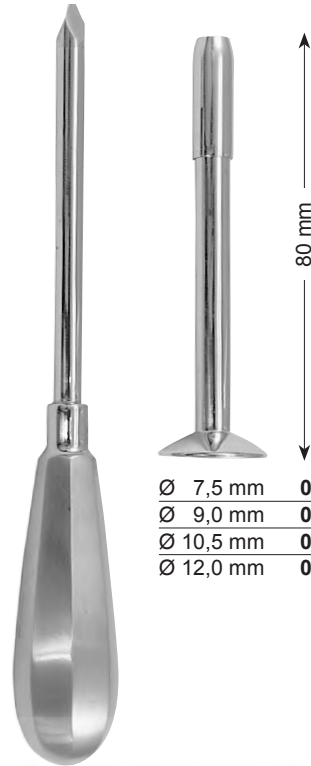

Ø 7,5 mm    **084-120-01**  
Ø 9,0 mm    **084-120-02**  
Ø 10,5 mm   **084-120-03**  
Ø 12,0 mm   **084-120-04**

**NELSON**  
21,0 cm, 8 1/2"

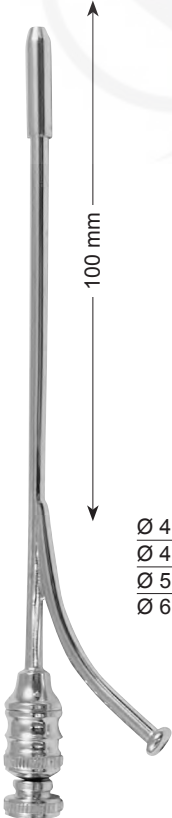

Ø 4,0 mm    **084-140-01**  
Ø 4,6 mm    **084-140-02**  
Ø 5,5 mm    **084-140-03**  
Ø 6,5 mm    **084-140-04**

**OCHSNER**  
14,0 cm, 5 1/2"

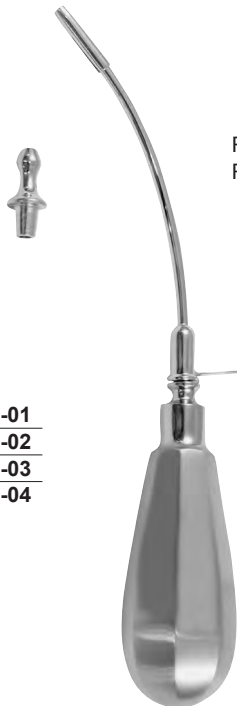

Record Konus  
Record cone

Ø 3,0 mm    **084-180-30**  
Ø 4,0 mm    **084-180-40**  
Ø 5,0 mm    **084-180-50**

**PIERCE**  
16,0 cm, 6 1/4"



**COAKLEY**  
14,0 cm, 5 1/4"  
**084-190-14**

Trokare, Saugrohre  
Trocars, Suction Tubes  
Trócares, Tubos para aspiración  
Trequarti, Tubi aspirazione

Ø 4,0 mm



**KRAUSE**  
16,0 cm, 6 1/4"

**LICHTWITZ**

Kieferhöhlentrokare  
Antrum trocars  
Trócares para el seno maxilar  
Trequarti per puntura del seno mascellare

Ø 3,0 mm	<b>084-184-30</b>
Ø 4,0 mm	<b>084-184-40</b>
Ø 5,0 mm	<b>084-184-50</b>
Ø 5,5 mm	<b>084-184-55</b>

Ø 1,8 mm



**LICHTWITZ**  
20,0 cm, 8"  
**084-170-00**



**LICHTWITZ**  
11,0 cm, 4 1/2"  
**084-172-00**



**DOUGLAS**  
Ø 3,0 mm  
**084-175-00**



**POOLE**  
22,0 cm, 8 5/8"  
Ø 6,0 mm **085-020-06**  
Ø 10,0 mm **085-020-10**



**POOLE**  
22,0 cm, 8 5/8"  
Ø 6,0 mm **085-021-06**  
Ø 8,0 mm **085-021-08**

**Saugrohre**  
**Suction Tubes**  
**Tubos para aspiración**  
**Tubi aspirazione**

auswechselbare Spitze  
interchangeable tip  
punta intercambiabile  
tipo intercambiabile



Ø 3,5 mm  
**085-010-35**



**085-024-00**  
Olive allein  
Olive only  
Oliva suelto  
Olivo solo



**COUPLAND**  
17,0 cm, 6<sup>3</sup>/<sub>4</sub>"  
**085-010-17**



**YANKAUER**  
27,0 cm, 10<sup>5</sup>/<sub>8</sub>"  
**085-000-27**



**DE BAKEY**  
27,0 cm, 10<sup>5</sup>/<sub>8</sub>"  
**085-008-27**



**ANTHONY**  
26,0 cm, 10<sup>1</sup>/<sub>4</sub>"  
**085-007-26**



**ANDREWS-PYNCHON**  
24,0 cm, 9<sup>1</sup>/<sub>2</sub>"  
**085-006-24**



**COOLEY**  
35,0 cm, 13<sup>3</sup>/<sub>4</sub>"  
Ø 8,0 mm  
**085-024-02**



**COOLEY**  
30,0 cm, 11<sup>3</sup>/<sub>4</sub>"  
Ø 7,0 mm  
**085-024-03**



**COOLEY**  
31,0 cm, 11<sup>3</sup>/<sub>4</sub>"  
Ø 10,0 mm  
**085-024-04**



**COOLEY**  
33,0 cm, 13"  
Ø 8,0 mm  
**085-024-01**



**BYRD**  
20,0 cm, 8"  
Ø 1,5 mm **085-012-15**  
Ø 2,5 mm **085-012-25**  
Ø 3,5 mm **085-012-35**

Ø 4,0 mm



**ADSON**  
21,0 cm, 8 1/4"  
**085-050-21**



**MAGILL**  
17,5 cm, 6 5/8"  
Ø 1,0 mm **085-060-01**  
Ø 2,0 mm **085-060-02**  
Ø 3,0 mm **085-060-03**  
Ø 4,0 mm **085-060-04**



**FRAZIER**  
19,0 cm, 7 1/2"

Charr. 6 **085-030-06**  
Charr. 8 **085-030-08**  
Charr. 10 **085-030-10**  
Charr. 12 **085-030-12**



**FERGUSON**  
18,0 cm, 7"

Charr. 6 **085-033-06**  
Charr. 8 **085-033-08**  
Charr. 10 **085-033-10**  
Charr. 12 **085-033-12**

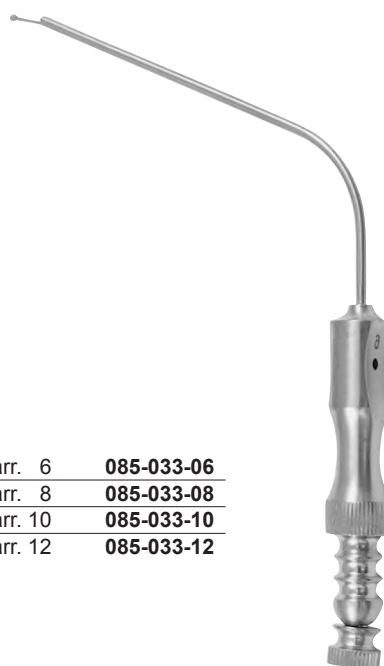

**POPPEN**  
13,0 cm, 5"

Charr. 6 **085-034-06**  
Charr. 8 **085-034-08**  
Charr. 10 **085-034-10**  
Charr. 12 **085-034-12**

Spezialkanülen  
Special Needles  
Agujas especiales  
Aghi speciali



LUER-LOCK

Packung zu 12 Stück  
Package of 12 pcs.  
Cajecita de 12 pzs.  
Confezione da 12 pezzi

- Ø 0,90 x 38 mm **086-000-01**
- Ø 0,80 x 32 mm **086-000-02**
- Ø 0,70 x 32 mm **086-000-03**
- Ø 0,65 x 28 mm **086-000-04**
- Ø 0,60 x 25 mm **086-000-05**
- Ø 0,50 x 23 mm **086-000-06**
- Ø 0,45 x 20 mm **086-000-07**

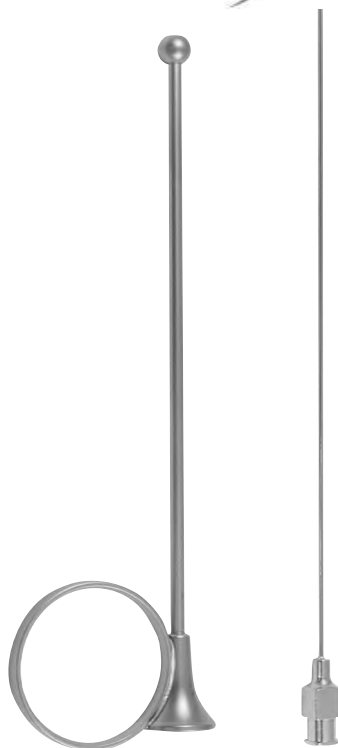

**IOWA**  
14,0 cm, 5<sup>1</sup>/<sub>4</sub>"  
**086-150-14**

Ø 1,0 x 185 mm

**086-150-01**  
Nadel  
Needle  
Aguja  
Aghi



**MOCK**  
6,0 cm, 2<sup>3</sup>/<sub>8</sub>"  
**086-200-06**



**SCHMID**  
15,0 cm, 6"



Ø 3,0 mm  
**086-140-03**



Ø 4,0 mm  
**086-140-04**



Ø 5,0 mm  
**086-140-05**



Ø 6,0 mm  
**086-140-06**

Gefäßspülkanülen, biegsam  
Vascular irrigation cannulae, malleable  
Cánulas vasculares para irrigación, maleables  
Aghi vascolari per irrigazione, malleabili



Ø 1,20 x 80 mm **086-210-12**  
Ø 1,50 x 80 mm **086-210-15**



Ø 2,00 x 100 mm **086-180-10**  
Ø 2,00 x 120 mm **086-180-12**  
Ø 2,00 x 150 mm **086-180-15**

**VERESS**



Kanülen zur Sternalpunktion  
Sternum puncture needles  
Agujas para la punción del esternón  
Aghi per puntura dello sterno



**KLIMA-ROSSEGER**  
Ø 1,60 x 40 mm  
**086-060-16**

Kanülen zur Lumbalpunktion  
Lumbar puncture needles  
Agujas para punción lumbar  
Aghi per punture lombari



Ø 0,8 x 70/80/90/100/120 mm **086-130-01**  
Ø 1,0 x 70/80/90/100/120 mm **086-130-02**  
Ø 1,2 x 70/80/90/100/120 mm **086-130-03**  
Ø 1,4 x 70/80/90/100/120 mm **086-130-04**  
Ø 1,6 x 70/80/90/100/120 mm **086-130-05**  
Ø 1,8 x 70/80/90/100/120 mm **086-130-06**  
Ø 2,0 x 70/80/90/100/120 mm **086-130-07**

**BIER**

Kanülen zur Lumbalpunktion  
Lumbar puncture needles  
Agujas para punción lumbar  
Aghi per punture lombari



QUINKE

Ø 1,20 x 76 mm **086-120-01**  
Ø 1,20 x 89 mm **086-120-02**  
Ø 1,00 x 76 mm **086-120-03**  
Ø 1,00 x 89 mm **086-120-04**  
Ø 0,70 x 76 mm **086-120-05**  
Ø 0,70 x 50 mm **086-120-06**  
Ø 0,70 x 89 mm **086-120-07**

Kanülen zur Lumbalpunktion  
Lumbar puncture needles  
Agujas para punción lumbar  
Aghi per punture lombari

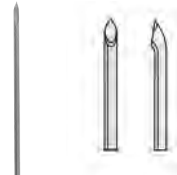

TUHOJ

Ø 1,20 x 76 mm **086-090-12**  
Ø 1,40 x 76 mm **086-090-14**  
Ø 1,60 x 76 mm **086-090-16**

Kanülen zur Leberblindpunktion  
Liver blind puncture needles  
Agujas para punción ciega del hígado  
Aghi per punture cieca del fegato



MENGHINI

Ø 1,00 x 35 mm **086-115-01**  
Ø 1,00 x 70 mm **086-115-02**  
Ø 1,20 x 70 mm **086-115-03**  
Ø 1,20 x 100 mm **086-115-04**  
Ø 1,40 x 70 mm **086-115-05**  
Ø 1,40 x 100 mm **086-115-06**  
Ø 1,60 x 70 mm **086-115-07**  
Ø 1,60 x 100 mm **086-115-08**

Kanülen zur gezielten Leberpunktion  
Needles for controlled liver puncture  
Agujas para la punción del hígado bajo el control laparoscópico  
Aghi per la punture controllata del fegato



MENGHINI

Ø 1,40 x 168 mm **086-117-14**  
Ø 1,80 x 168 mm **086-117-18**

Trokare für Kanülen  
Trocars for needles  
Trocares para agujas  
Trequarti oer aghi



Ø 1,40 x 168 mm **086-230-14**  
Ø 1,80 x 168 mm **086-230-18**



1 ml	<b>087-051-01</b>
2 ml	<b>087-051-02</b>
5 ml	<b>087-051-05</b>
10 ml	<b>087-051-10</b>
20 ml	<b>087-051-20</b>
50 ml	<b>087-051-50</b>



1 ml	<b>087-001-01</b>
2 ml	<b>087-001-02</b>
5 ml	<b>087-001-05</b>
10 ml	<b>087-001-10</b>
20 ml	<b>087-001-20</b>
50 ml	<b>087-001-50</b>



1 ml	<b>087-061-01</b>
2 ml	<b>087-061-02</b>



**LUER**

1 ml	<b>087-050-01</b>
2 ml	<b>087-050-02</b>
5 ml	<b>087-050-05</b>
10 ml	<b>087-050-10</b>
20 ml	<b>087-050-20</b>
50 ml	<b>087-050-50</b>



**LUER-LOCK**

1 ml	<b>087-000-01</b>
2 ml	<b>087-000-02</b>
5 ml	<b>087-000-05</b>
10 ml	<b>087-000-10</b>
20 ml	<b>087-000-20</b>
50 ml	<b>087-000-50</b>



**LUER-LOCK**

2 ml	<b>087-055-02</b>
5 ml	<b>087-055-05</b>
10 ml	<b>087-055-10</b>

**INSULIN LUER**



1 ml	<b>087-060-01</b>
2 ml	<b>087-060-02</b>

Spritzen  
Syringes  
Jeringas  
Siringhe



50 ml **087-071-05**  
100 ml **087-071-10**  
150 ml **087-071-15**  
200 ml **087-071-20**

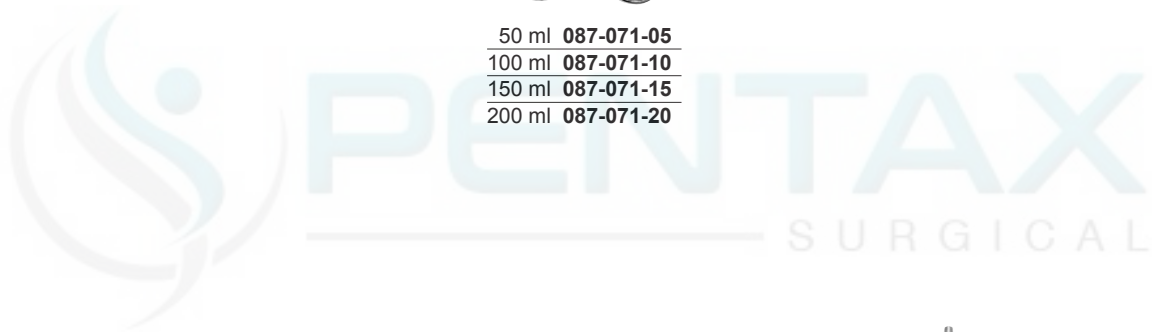

10 ml **087-081-10**  
20 ml **087-081-20**  
30 ml **087-081-30**  
50 ml **087-081-50**



**JANET**

50 ml **087-070-05**  
100 ml **087-070-10**  
150 ml **087-070-15**  
200 ml **087-070-20**

Zwischenstück, LUER-LOCK weiblich  
Connecting piece, LUER-LOCK female  
Pieza de conexión, LUER-LOCK hembra  
Raccordo, LUER-LOCK femmina



087-911-00

Zwischenstück, LUER-LOCK männlich  
Connecting piece, LUER-LOCK male  
Pieza de conexión, LUER-LOCK masculino  
Raccordo, LUER-LOCK maschio



087-930-02

Zwischenstück, LUER-LOCK männlich  
Connecting piece, LUER-LOCK male  
Pieza de conexión, LUER-LOCK masculino  
Raccordo, LUER-LOCK maschio

Ø 6 mm

Ø 8 mm



087-912-06



087-912-08

Zwischenstück, LUER-LOCK weiblich  
Connecting piece, LUER-LOCK female  
Pieza de conexión, LUER-LOCK hembra  
Raccordo, LUER-LOCK femmina



087-913-00

Zwischenstück, LUER-LOCK männlich  
Connecting piece, LUER-LOCK male  
Pieza de conexión, LUER-LOCK masculino  
Raccordo, LUER-LOCK maschio



087-935-00

Durchflußhahn, LL männl. – LL weibl.  
Stopcock, LL male – LL female  
Llave, LL masculino – LL hembra  
Rubinetto, LL maschio – LL femmina



087-939-00

Durchflußhahn, LL weiblich  
Stopcock, LL female  
Llave, LL hembra  
Rubinetto, LL femmina



087-920-00

Dreiweghahn, 1 LL männl. – 2 LL weibl.  
Three-way-stopcock, 1 LL male – 2 LL female  
Llave de 3 vías, 1 LL masculino – 2 LL hembra  
Rubinetto a tre vie, 1 LL maschio – 2 LL femmina



087-922-00

Dreiweghahn, 3 LL weiblich  
Three-way-stopcock, 3 LL female  
Llave de 3 vías, 3 LL hembra  
Rubinetto a tre vie, 3 LL femmina



087-926-00



**Galle, Leber, Niere, Blase, Urologie  
Gall, Liver, Kidney, Bladder, Urology  
Bilis, Hígado, Riñon, Vejiga, Urología  
Bile, Fegato, Rene, Vescica, Urologia**

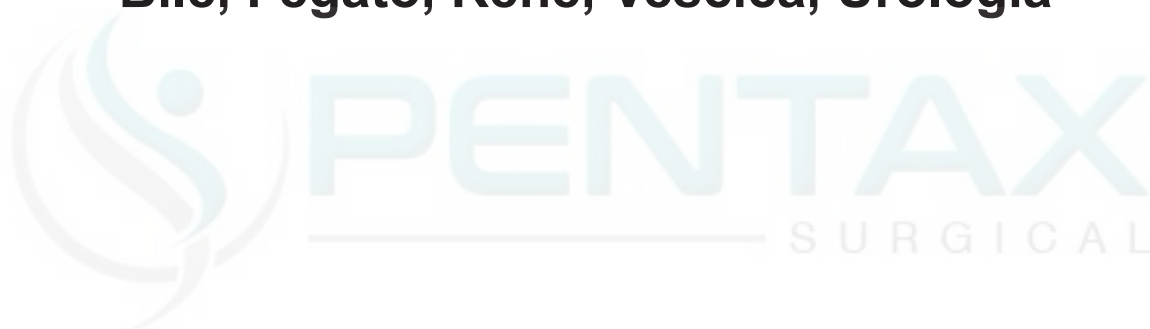

Nierensteinzangen, Gallensteinzangen  
 Kidney Stone Forceps, Gall Stone Forceps  
 Pinzas para los cálculos renales, Pinzas para los cálculos biliare  
 Pinze per calcoli renali, Pinze per calcoli biliari



**RANDALL**



23,0 cm, 9"  
 158-001-01



22,0 cm, 8<sup>5</sup>/<sub>8</sub>"  
 158-001-02

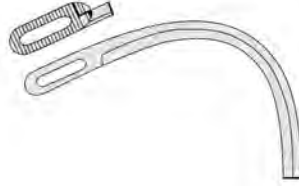

22,0 cm, 8<sup>5</sup>/<sub>8</sub>"  
 158-001-03



22,0 cm, 8<sup>5</sup>/<sub>8</sub>"  
 158-001-04

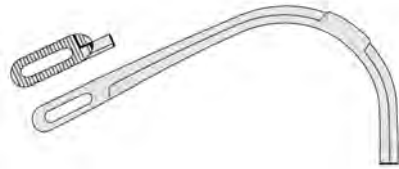

19,0 cm, 7<sup>1</sup>/<sub>2</sub>"  
 158-001-05

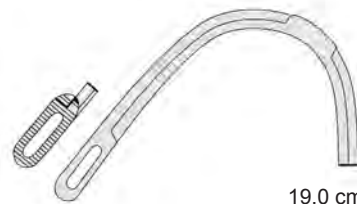

19,0 cm, 7<sup>1</sup>/<sub>2</sub>"  
 158-001-06

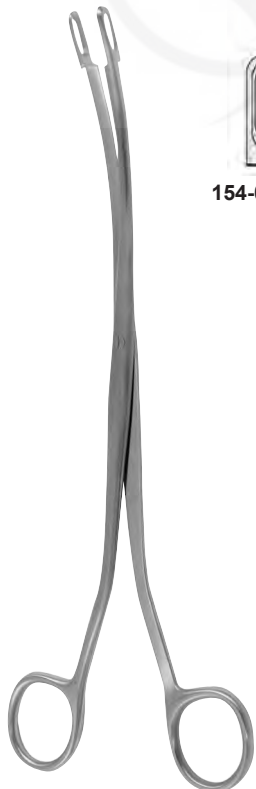

**DESJARDINS**  
 23,0 cm, 9"



154-001-01



154-001-02



**MIXTER**  
 22,0 cm, 8<sup>5</sup>/<sub>8</sub>"  
 154-021-22



**MAYO BLAKE**  
 20,0 cm, 8"  
 154-008-20

20,0 cm, 8"  
 154-009-20



**BLAKE**  
20,0 cm, 8"  
154-006-20

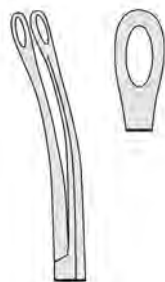

20,0 cm, 8"  
154-005-20



**TURNER-WARWICK**  
18,0 cm, 7"

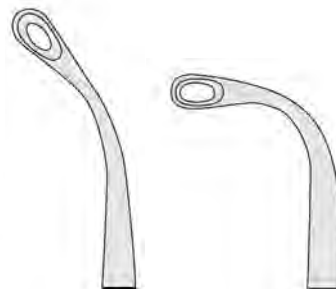

154-031-01

154-031-03



**CZERNY**  
24,5 cm, 9<sup>5</sup>/<sub>8</sub>"  
154-039-24

Gallensteinlöffel  
 Gall Stone Scoops  
 Cucharillas para los cálculos biliares  
 Cucchiari per calcoli biliari



**LUER-KÖRTE**  
 24,0 cm, 9½"



Fig. 000  
 2,8 mm  
 154-080-01



Fig. 00  
 3,4 mm  
 154-080-02



Fig. 2  
 6,7 mm  
 154-080-05



Fig. 3  
 8,0 mm  
 154-080-06

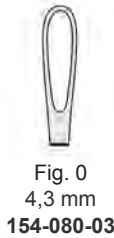

Fig. 0  
 4,3 mm  
 154-080-03



Fig. 1  
 5,5 mm  
 154-080-04



Fig. 4  
 11,0 mm  
 154-080-07



Fig. 5  
 15,0 mm  
 154-080-08



**FERGUSON**  
 21,5 cm, 8½"  
 154-070-01



**MAYO**  
 27,0 cm, 10⅝"  
 154-072-01



**MAYO**  
 27,0 cm, 10⅝"



154-074-01

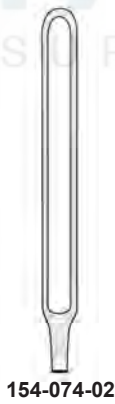

154-074-02



**MOYNIHAN**  
 34,0 cm, 13⅜"  
 154-076-34



**MAYO**  
32,0 cm, 12<sup>1</sup>/<sub>2</sub>"  
154-078-32



**OCHSNER**  
35,0 cm, 13<sup>3</sup>/<sub>4</sub>"  
154-082-35



**DESJARDINS**  
28,0 cm, 11"

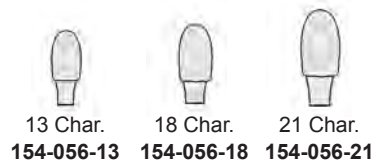

**MOORE**  
30,0 cm, 12"  
154-084-30

Gallenblasenlöffel  
Gall bladder scoope  
Cuccharilla para la vesicula biliar  
Cucchiaio per colecisti



**DESJARDINS**  
28,0 cm, 11"

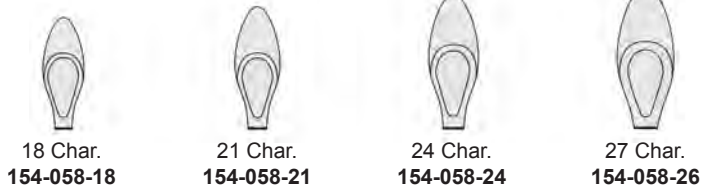

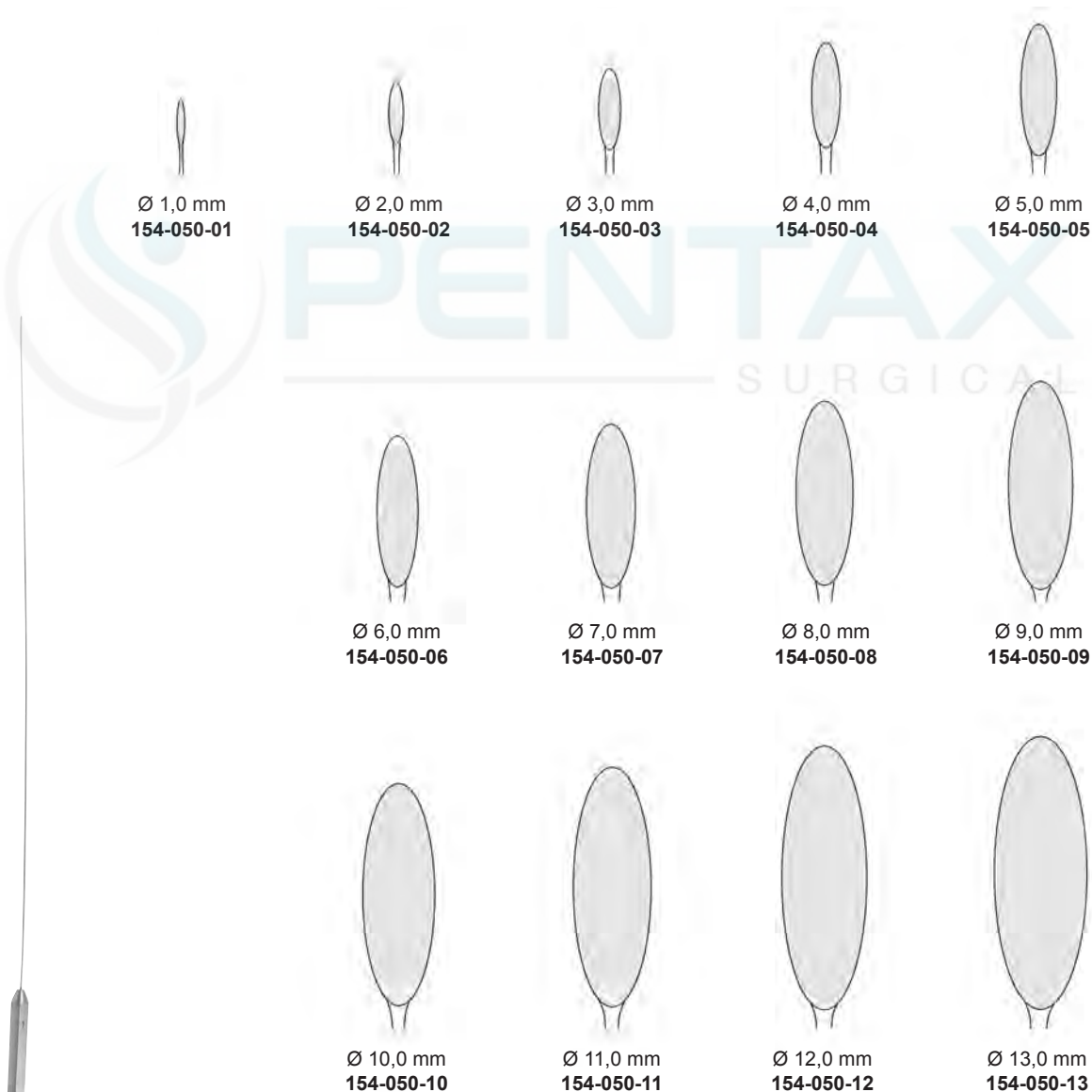

**BAKES**  
 30,0 cm, 11<sup>3</sup>/<sub>4</sub>"

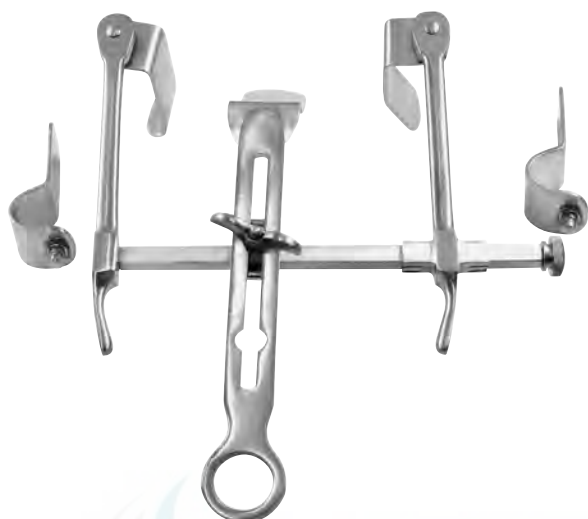

**THOMSON-WALKER**  
170-182-00

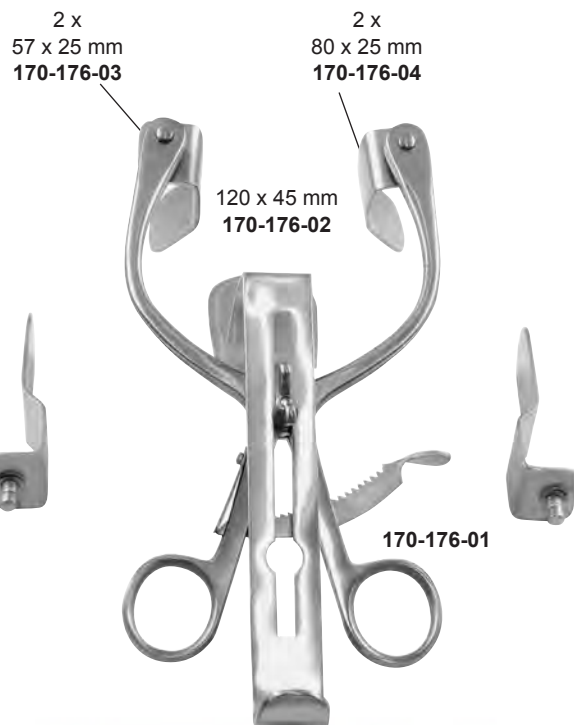

**MILLIN**  
170-176-00

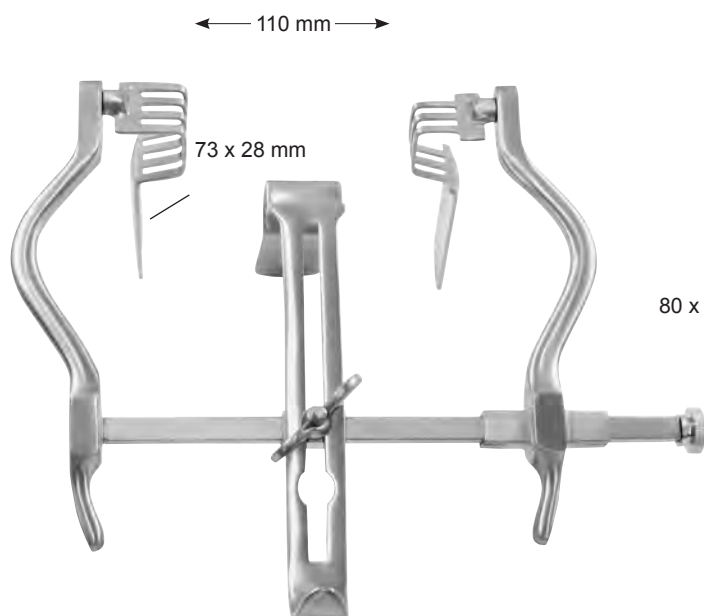

**JUDD-MASSON**  
170-172-00

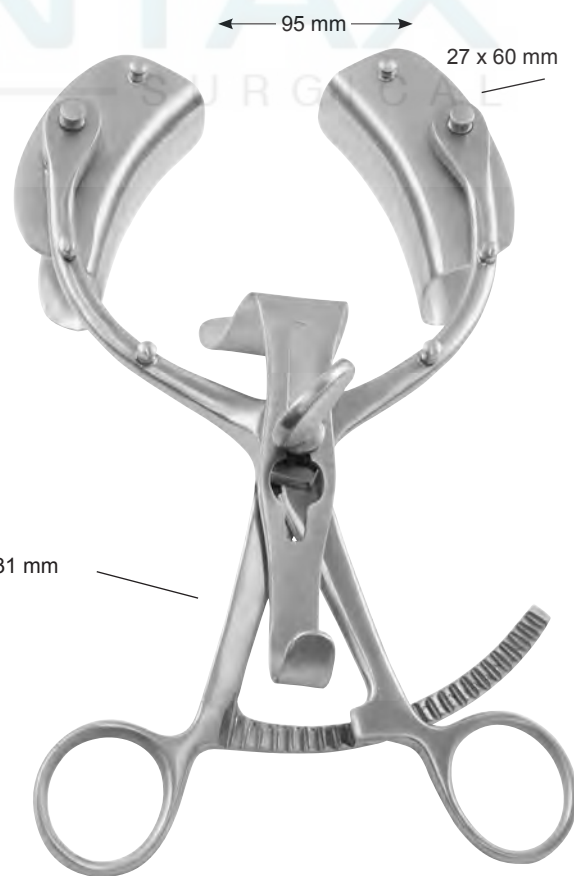

**LEGUEU**  
170-160-00



**MILLIN**  
 23,0 cm, 9"  
 170-073-23



**ATRAUMA**

**MILLIN**  
 24,0 cm, 9½"  
 170-071-24



**MILLIN**  
 24,0 cm, 9½"  
 170-077-24



**MILLIN**  
 23,0 cm, 9"  
 170-075-23



**MILLIN**  
 28,5 cm, 11¼"  
 170-150-24

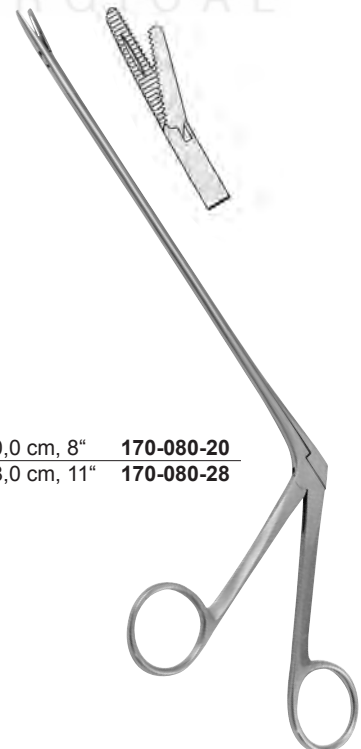

20,0 cm, 8" **170-080-20**  
 28,0 cm, 11" **170-080-28**

**MATHIEU**



**YOUNG**  
21,0 cm, 8<sup>1</sup>/<sub>4</sub>"  
170-230-21

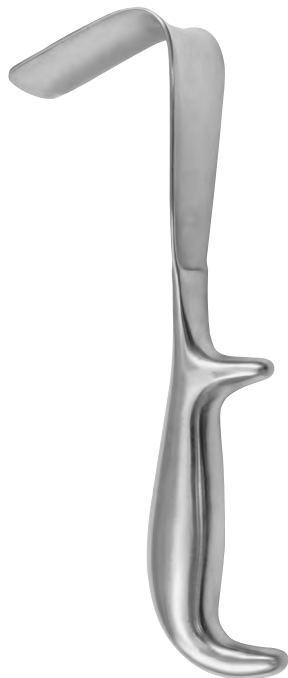

**YOUNG**  
22,0 cm, 8<sup>5</sup>/<sub>8</sub>"  
170-236-22



**YOUNG**  
21,0 cm, 8<sup>1</sup>/<sub>4</sub>"  
170-238-21



**YOUNG**  
22,0 cm, 8<sup>5</sup>/<sub>8</sub>"  
170-240-22



90 x 35 mm

**LEGUEU**  
26,0 cm, 10<sup>1</sup>/<sub>4</sub>"  
170-250-26



90 x 61 mm

**KOCHER**  
23,5 cm, 9<sup>1</sup>/<sub>4</sub>"  
170-257-23



für Männer  
for men  
para hombres  
per uomini

Char. 8	170-650-08
Char. 10	170-650-10
Char. 12	170-650-12
Char. 14	170-650-14
Char. 16	170-650-16
Char. 18	170-650-18
Char. 20	170-650-20
Char. 22	170-650-22
Char. 24	170-650-24

29,0 cm, 11 1/2"



für Frauen  
for women  
para mujeres  
per donne

Char. 6	170-660-06
Char. 7	170-660-07
Char. 8	170-660-08
Char. 9	170-660-09
Char. 10	170-660-10
Char. 11	170-660-11
Char. 12	170-660-12
Char. 13	170-660-14
Char. 15	170-660-15
Char. 16	170-660-16
Char. 18	170-660-18
Char. 20	170-660-20
Char. 24	170-660-24

16,0 cm, 6 1/4"



**STRAUSS**  
11,0 cm, 4 1/3"  
170-349-11



**STOCKMANN**  
8,0 cm, 3 1/4"  
170-345-08

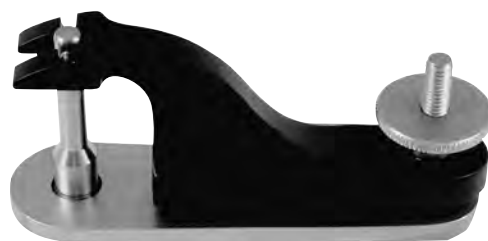

**COMCO**

Ø 8,0 mm	170-350-08
Ø 11,0 mm	170-350-11
Ø 13,0 mm	170-350-13
Ø 16,0 mm	170-350-16
Ø 21,0 mm	170-350-21
Ø 26,0 mm	170-350-26
Ø 32,0 mm	170-350-32

**Magen, Darm, Mastdarm**  
**Stomach, Intestines, Rectum**  
**Estómago, Intestino, Recto**  
**Stomaco, Intestino, Retto**

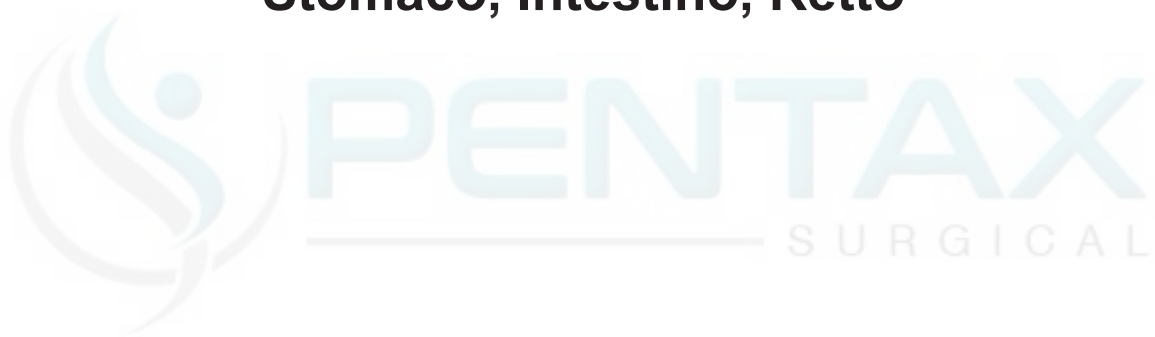

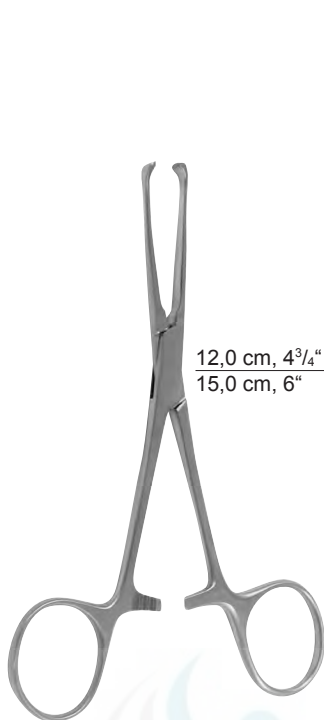

12,0 cm, 4<sup>3</sup>/<sub>4</sub>" **160-000-12**  
 15,0 cm, 6" **160-000-15**

ALLIS-BABY

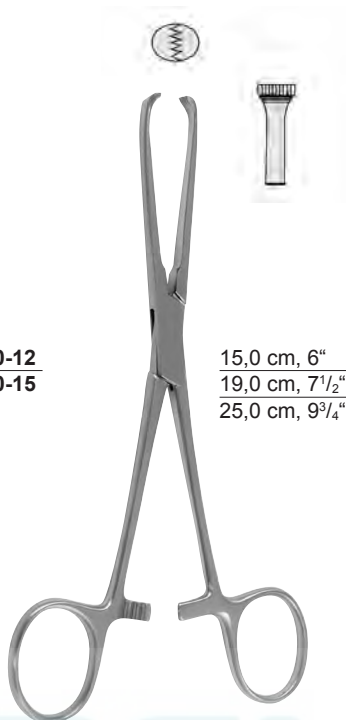

15,0 cm, 6" **160-004-15**  
 19,0 cm, 7<sup>1</sup>/<sub>2</sub>" **160-004-19**  
 25,0 cm, 9<sup>3</sup>/<sub>4</sub>" **160-004-25**

ALLIS

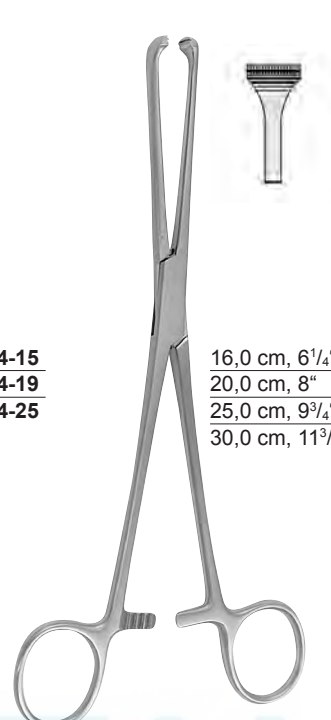

16,0 cm, 6<sup>1</sup>/<sub>4</sub>" **160-124-16**  
 20,0 cm, 8" **160-124-20**  
 25,0 cm, 9<sup>3</sup>/<sub>4</sub>" **160-124-25**  
 30,0 cm, 11<sup>3</sup>/<sub>4</sub>" **160-124-30**

ALLIS-ATRAUMA



15,5 cm, 6" **160-020-15**  
 20,0 cm, 8" **160-020-20**  
 23,0 cm, 9" **160-020-23**

ALLEN

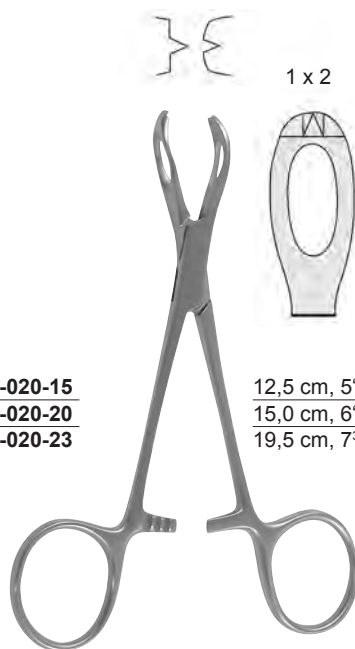

12,5 cm, 5" **160-030-12**  
 15,0 cm, 6" **160-030-15**  
 19,5 cm, 7<sup>3</sup>/<sub>4</sub>" **160-030-19**

LANE

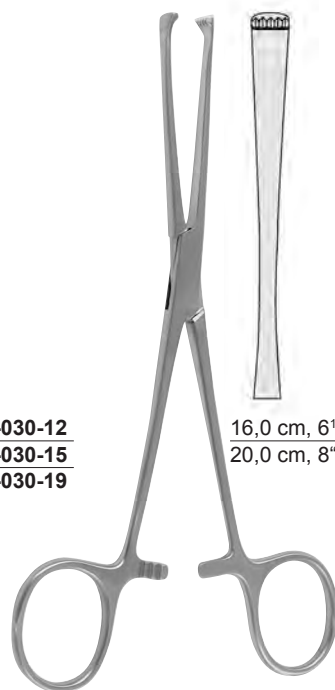

16,0 cm, 6<sup>1</sup>/<sub>4</sub>" **160-178-16**  
 20,0 cm, 8" **160-178-20**

LOCKWOOD-ALLIS

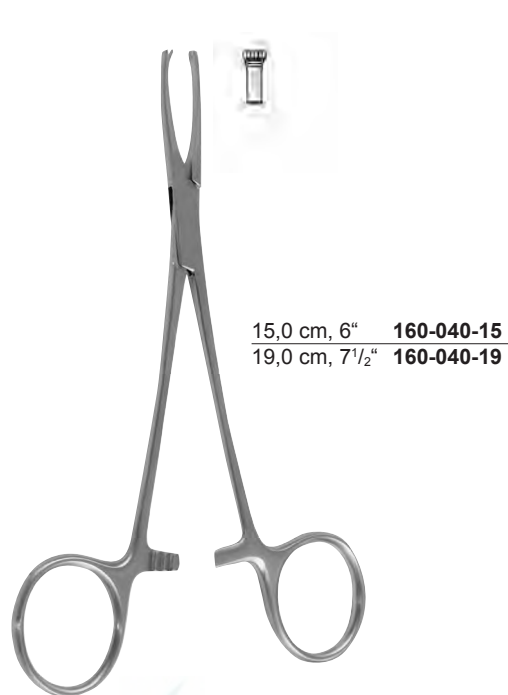

15,0 cm, 6" **160-040-15**  
19,0 cm, 7 1/2" **160-040-19**

**JUDD-ALLIS**



**LITTLEWOOD**  
18,5 cm, 7 1/4"  
**160-060-16**



**ALLIS-ADAIR**  
15,5 cm, 6"  
**160-010-15**



**BOYS-ALLIS**  
15,5 cm, 6"  
**160-012-15**



**THOMS-ALLIS**  
20,0 cm, 8"  
**160-050-20**



**ALLIS**  
20,0 cm, 8"  
**160-014-20**



**LOCKWOOD**  
 20,0 cm, 8"  
 160-169-20



**WILLIAMS**  
 16,0 cm, 6¼"  
 160-070-16



**BABCOCK**

16,0 cm, 6¼" **160-006-16**  
 18,0 cm, 7" **160-006-18**  
 20,0 cm, 8" **160-006-20**  
 24,0 cm, 9½" **160-006-24**



**BABCOCK-ATRAUMA**

16,0 cm, 6¼" **164-006-16**  
 20,0 cm, 8" **164-006-20**



**BABCOCK-T C**

16,0 cm, 6¼" **161-006-16**  
 20,0 cm, 8" **161-006-20**



**DUVAL-TC**  
 20,0 cm, 8"  
 161-170-20

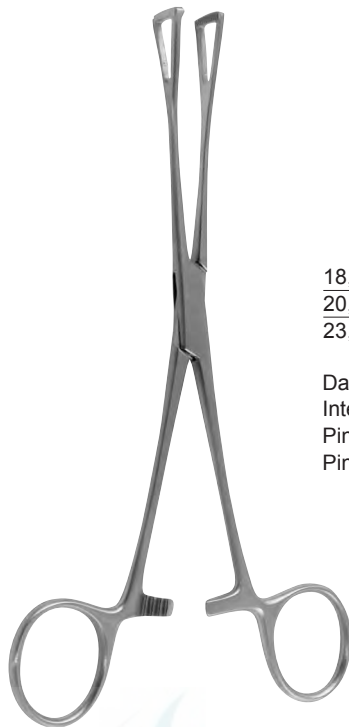

**DUVAL**

18,0 cm, 7"	<b>160-170-18</b>	
20,0 cm, 8"	<b>160-170-20</b>	<b>160-172-20</b>
23,0 cm, 9"		<b>160-172-23</b>

Darm- und Gewebefaßzangen  
Intestinal and Tissue Grasping Forceps  
Pinzas intestinales y para tejidos  
Pinze da presa per intestino e tessuti



**BABY-DOYEN**  
18,0 cm, 7"

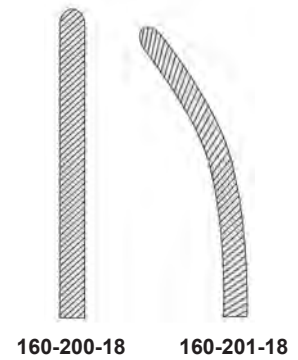

**160-200-18**

**160-201-18**



**DOYEN**

21,0 cm, 8 <sup>1</sup> / <sub>4</sub> "	<b>160-210-21</b>	21,0 cm, 8 <sup>1</sup> / <sub>4</sub> "	<b>160-211-21</b>
23,0 cm, 9"	<b>160-210-23</b>	23,0 cm, 9"	<b>160-211-23</b>

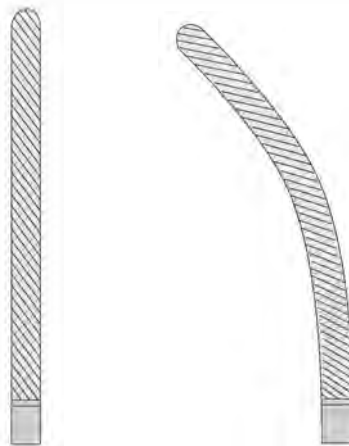

Darmklemmen  
 Intestinal Clamp Forceps  
 Pinzas-clamps intestinales  
 Pinze intestinal i

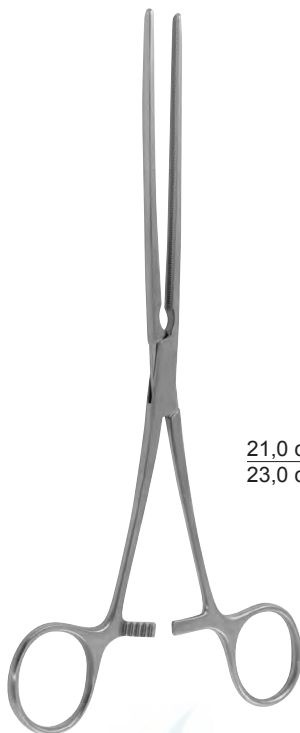

DOYEN

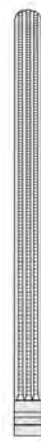

21,0 cm, 8<sup>1</sup>/<sub>4</sub>" **164-210-21**  
 23,0 cm, 9" **164-210-23**

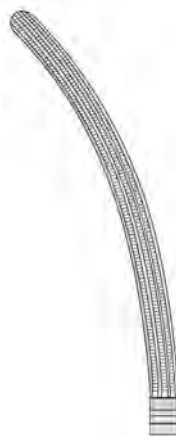

21,0 cm, 8<sup>1</sup>/<sub>4</sub>" **164-211-21**  
 23,0 cm, 9" **164-211-23**

mit atraumatischer Zahnung  
 with atraumatic serration  
 con bacos atraumáticas  
 con morsi atraumatici



KOCHER



22,0 cm, 8<sup>5</sup>/<sub>8</sub>" **160-234-22**  
 25,0 cm, 9<sup>3</sup>/<sub>4</sub>" **160-234-25**  
 28,0 cm, 11" **160-234-28**



22,0 cm, 8<sup>5</sup>/<sub>8</sub>" **160-235-22**  
 25,0 cm, 9<sup>3</sup>/<sub>4</sub>" **160-235-25**  
 28,0 cm, 11" **160-235-28**



mit atraumatischer Zahnung  
with atraumatic serration  
con bacos atraumáticos  
con morsi atraumatici

KOCHER

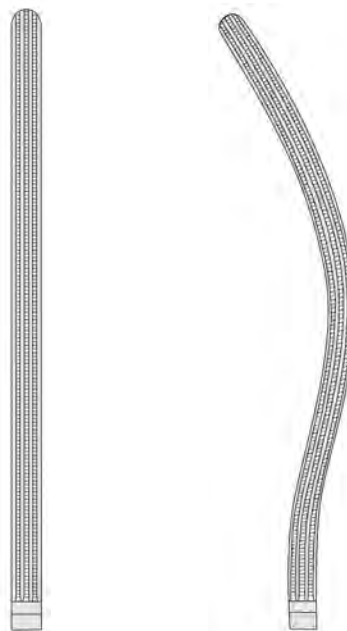

22,0 cm, 8 <sup>5</sup> / <sub>8</sub> "	<b>164-234-22</b>	22,0 cm, 8 <sup>5</sup> / <sub>8</sub> "	<b>164-235-22</b>
25,0 cm, 9 <sup>3</sup> / <sub>4</sub> "	<b>164-234-25</b>	25,0 cm, 9 <sup>3</sup> / <sub>4</sub> "	<b>164-235-25</b>
28,0 cm, 11"	<b>164-234-28</b>	28,0 cm, 11"	<b>164-235-28</b>



# PENTAX

SURGICAL



MAYO-ROBSON

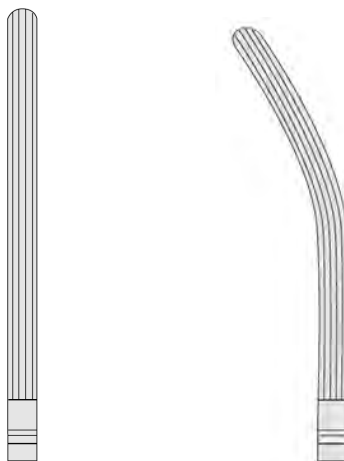

21,0 cm, 8 <sup>1</sup> / <sub>4</sub> "	<b>160-230-21</b>	21,0 cm, 8 <sup>1</sup> / <sub>4</sub> "	<b>160-231-21</b>
23,0 cm, 9"	<b>160-230-23</b>	23,0 cm, 9"	<b>160-231-23</b>
25,0 cm, 9 <sup>3</sup> / <sub>4</sub> "	<b>160-230-25</b>	25,0 cm, 9 <sup>3</sup> / <sub>4</sub> "	<b>160-231-25</b>

Darmklemmen  
 Intestinal Clamp Forceps  
 Pinzas-clamps intestinales  
 Pinze intestinali

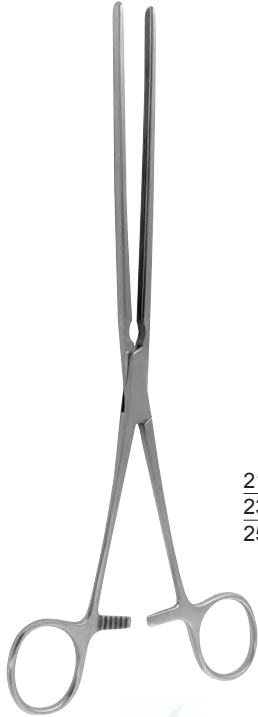

**MAYO-ROBSON**

21,0 cm, 8<sup>1</sup>/<sub>4</sub>" **164-230-21**  
 23,0 cm, 9" **164-230-23**  
 25,0 cm, 9<sup>3</sup>/<sub>4</sub>" **164-230-25**

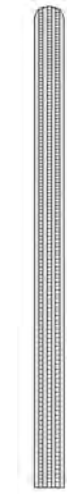

21,0 cm, 8<sup>1</sup>/<sub>4</sub>" **164-231-21**  
 23,0 cm, 9" **164-231-23**  
 25,0 cm, 9<sup>3</sup>/<sub>4</sub>" **164-231-25**

mit atraumatischer Zahnung  
 with atraumatic serration  
 con bacos atraumáticos  
 con morsi atraumatici

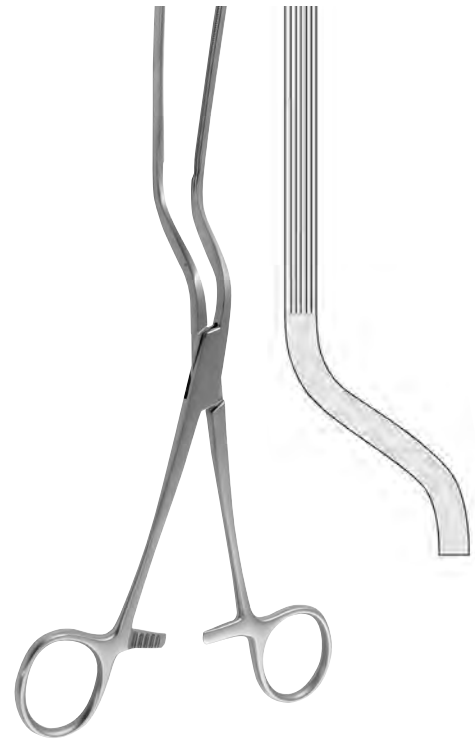

**BRUNNER**  
 24,0 cm, 9<sup>1</sup>/<sub>2</sub>"  
**160-240-24**

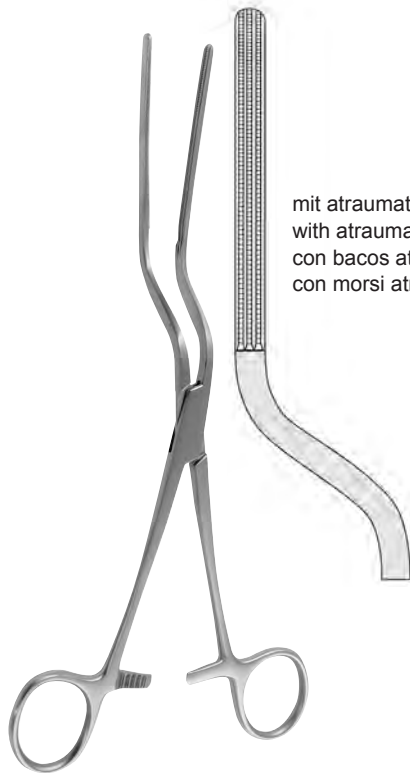

**BRUNNER**  
 24,0 cm, 9<sup>1</sup>/<sub>2</sub>"  
**164-240-24**

mit atraumatischer Zahnung  
 with atraumatic serration  
 con bacos atraumáticos  
 con morsi atraumatici

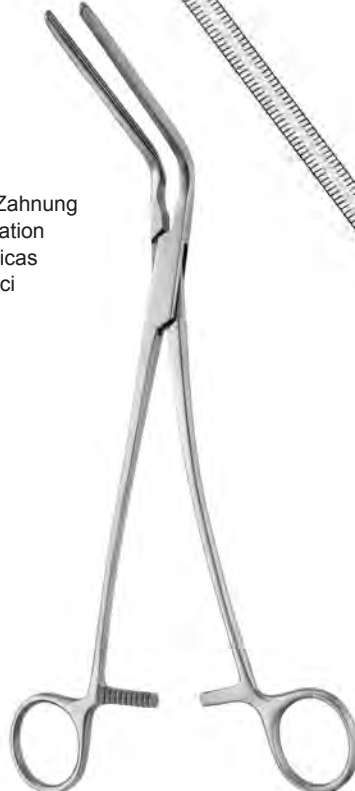

**GLASSMAN**  
 23,0 cm, 9"  
**160-259-23**



**GLASSMAN**  
 23,5 cm, 9<sup>1</sup>/<sub>4</sub>"  
**160-253-23**



Maußlänge  
 length of jaws  
 longitud de la boca  
 bocche lungh

5,0 cm, 2"	<b>160-320-05</b>
7,0 cm, 2 1/2"	<b>160-320-07</b>
10,0 cm, 4"	<b>160-320-10</b>

**DE MARTEL-WOLFSON**



**DE MARTEL-WOLFSON**

8,5 cm, 3 1/2"  
**160-340-08**



**DE MARTEL-WOLFSON**

26,0 cm, 10 1/4"  
**160-325-26**

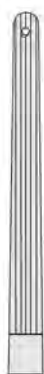

**160-310-15**  
 mit Stift  
 with pin  
 con espiga  
 con perno



**160-311-15**  
 ohne Stift  
 without pin  
 sin espiga  
 senza perno



**BABY-PAYR**  
 15,0 cm, 6"

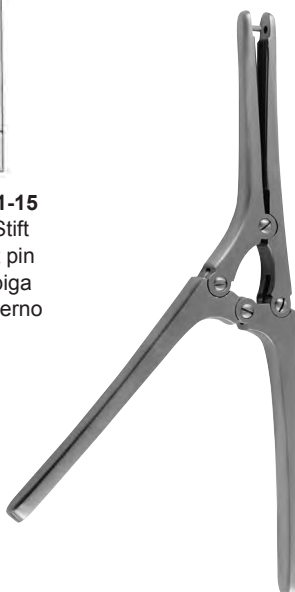

**PAYR**



21,0 cm, 8 1/4" **160-310-21**



29,0 cm, 11 1/2" **160-310-29**

mit Stift with pin con espiga con perno	ohne Stift without pin sin espiga senza perno
--	--

Darm- und Magenklappen  
 Intestinal and Stomach Clamp Forceps  
 Pinzas-clamps intestinales y estomacales  
 Pinze per intestino e stomaco



160-360-30

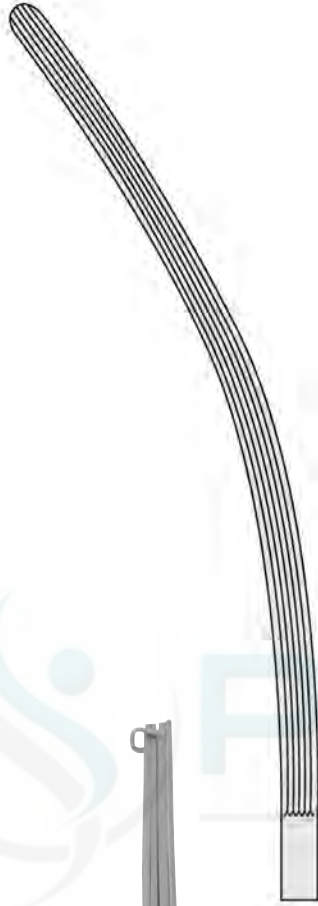

160-361-30



160-364-33

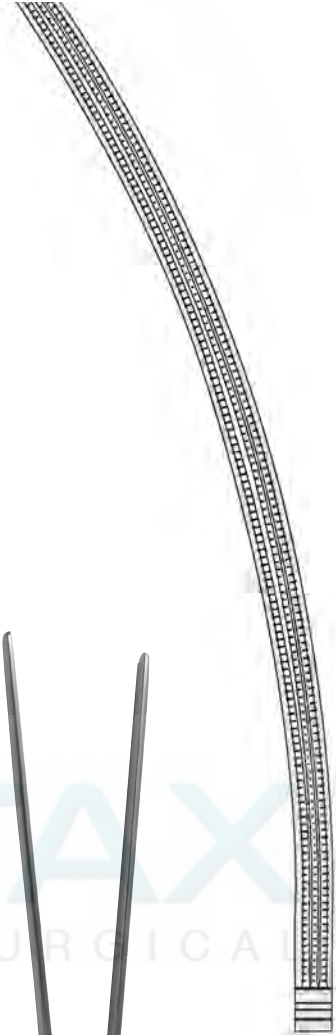

160-365-33

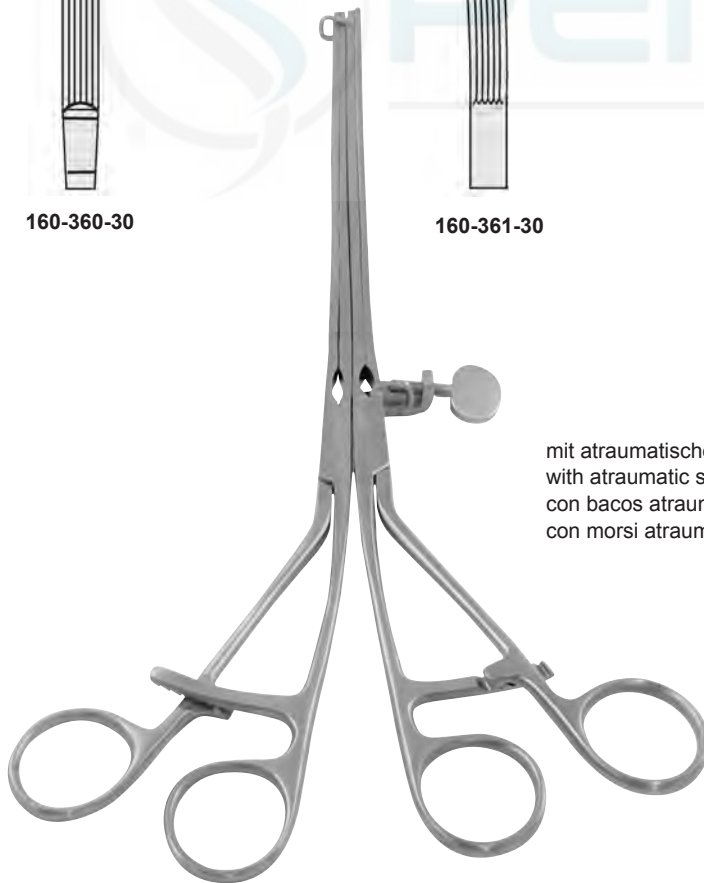

**LANE**  
 30,0 cm, 11<sup>3</sup>/<sub>4</sub>"

mit atraumatischer Zahnung  
 with atraumatic serration  
 con bacos atraumáticos  
 con morsi atraumatici



**SCUDDER**  
 33,0 cm, 13"



**MIKULICZ**  
19,0 cm, 7½"  
168-010-19

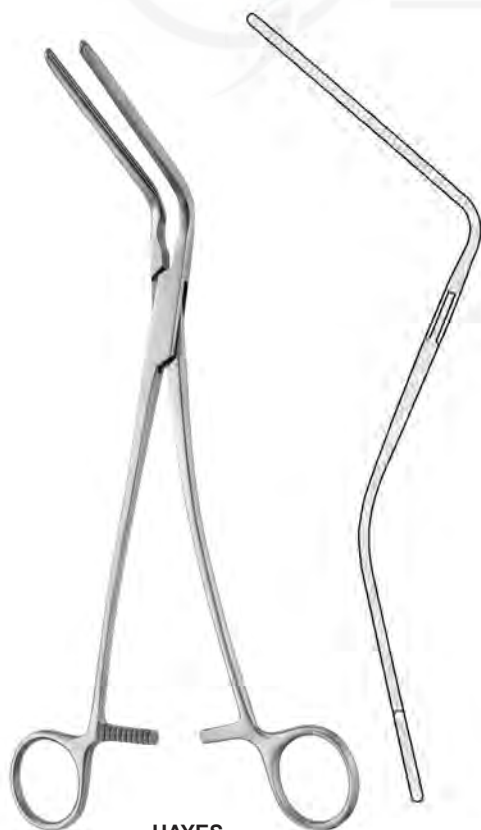
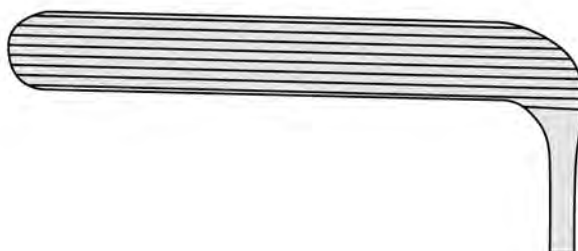

**HAYES**

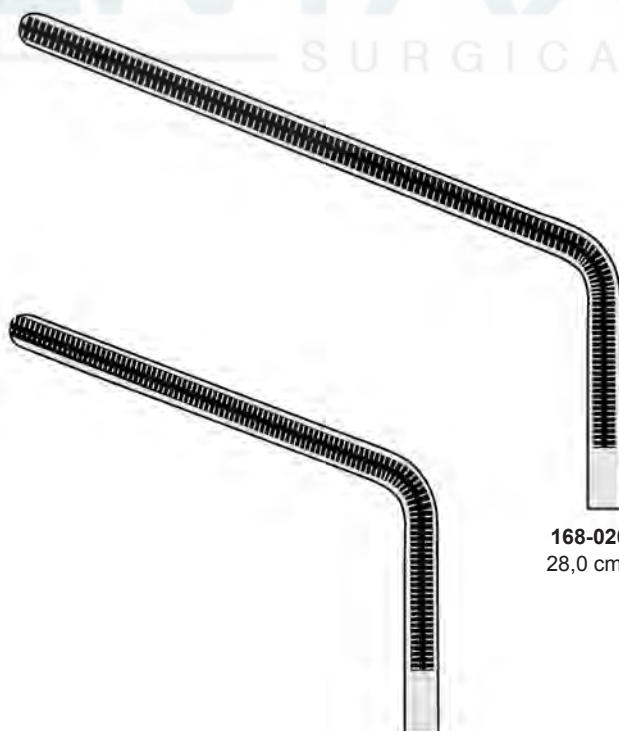

**168-020-26**  
26,0 cm, 10"

**168-020-28**  
28,0 cm, 11"

Mastdarm-Rektum-Spekula  
Rectal Specula  
Espéculos para el recto  
Speculi rettali

17 x 89 mm



**SIMS**  
15,0 cm, 6"  
168-108-15

17 x 89 mm



**SIMS**  
15,0 cm, 6"  
168-110-15



25 x 89 mm



**MATHIEU**  
21,0 cm, 8 1/4"  
168-150-21

75 x 23 mm

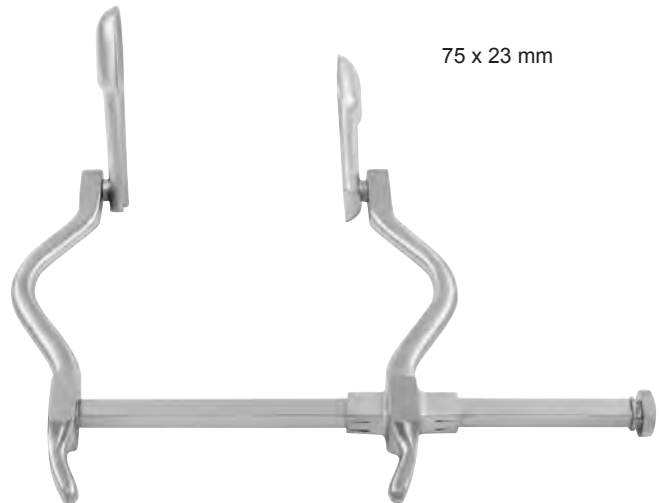

**SMITH-BUIE**  
15,0 cm, 6"  
168-160-15

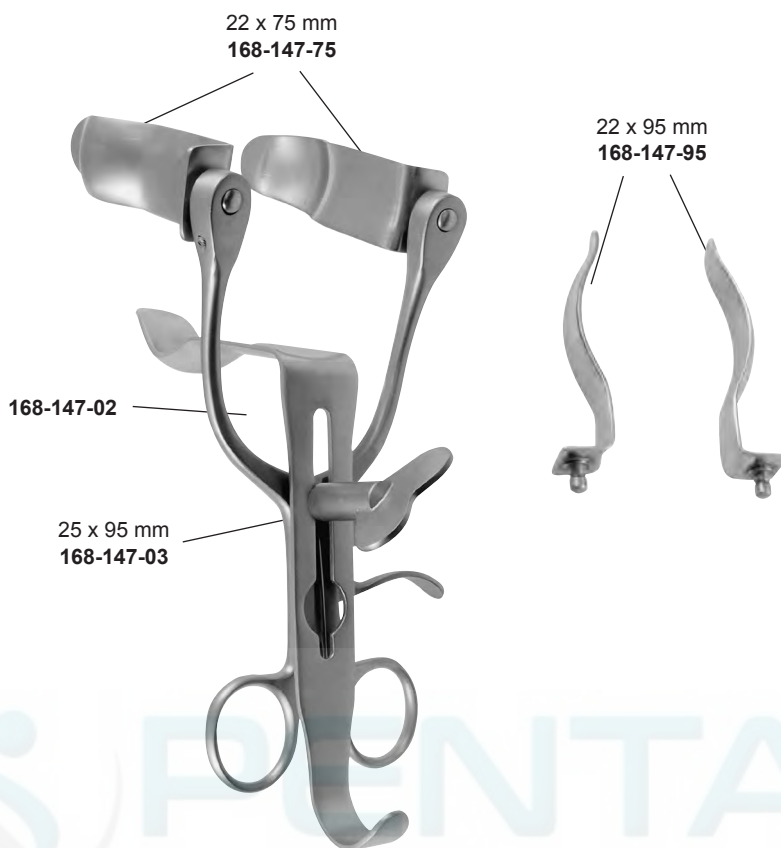

**ALAN PARKS**  
13,5 cm, 5<sup>3</sup>/<sub>8</sub>"  
**168-147-00**

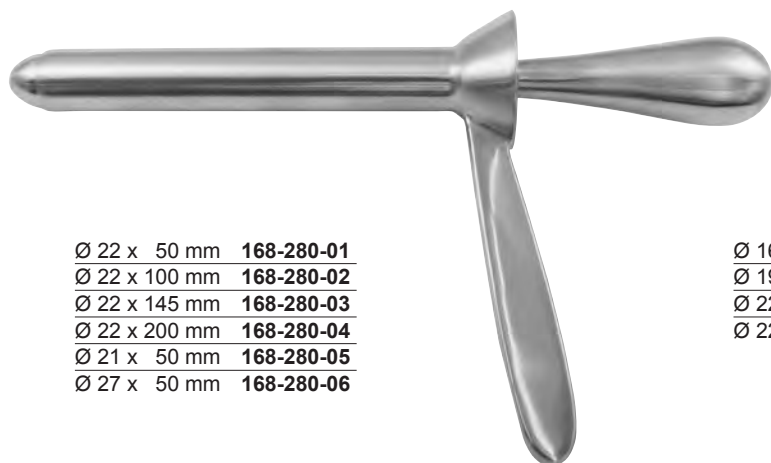

- Ø 22 x 50 mm **168-280-01**
- Ø 22 x 100 mm **168-280-02**
- Ø 22 x 145 mm **168-280-03**
- Ø 22 x 200 mm **168-280-04**
- Ø 21 x 50 mm **168-280-05**
- Ø 27 x 50 mm **168-280-06**

**HAYES**



- Ø 16 x 65 mm **168-212-01**
- Ø 19 x 65 mm **168-212-02**
- Ø 22 x 65 mm **168-212-03**
- Ø 22 x 130 mm **168-212-04**

**HIRSCHMANN**

Anuskope, Proktoskope  
Anoscope, Proctoscopes  
Anoscopios, Proctoscopios  
Anoscopi, Proctoscopi



Ø 22 x 65 mm **168-250-22**  
Ø 30 x 65 mm **168-250-30**

**CHELSEA EATON**



ohne Kaltlichtträger  
without cold light carrier  
sin portador para luz fría  
senza luce fredda

**IVES FANSLER**  
Ø 22 mm  
**168-268-01**

mit Kaltlichtträger  
with cold light carrier  
con portador para luz fría  
con luce fredda

**IVES FANSLER**  
Ø 22 mm  
**168-268-02**



28,0 cm, 11" **168-300-28**  
35,0 cm, 13<sup>3</sup>/<sub>4</sub>" **168-300-35**  
42,0 cm, 16<sup>1</sup>/<sub>2</sub>" **168-300-42**



28,0 cm, 11" **168-311-28**  
35,0 cm, 13<sup>3</sup>/<sub>4</sub>" **168-311-35**  
42,0 cm, 16<sup>1</sup>/<sub>2</sub>" **168-311-42**



28,0 cm, 11" **168-301-28**  
35,0 cm, 13<sup>3</sup>/<sub>4</sub>" **168-301-35**  
42,0 cm, 16<sup>1</sup>/<sub>2</sub>" **168-301-42**



28,0 cm, 11" **168-312-28**  
35,0 cm, 13<sup>3</sup>/<sub>4</sub>" **168-312-35**  
42,0 cm, 16<sup>1</sup>/<sub>2</sub>" **168-312-42**

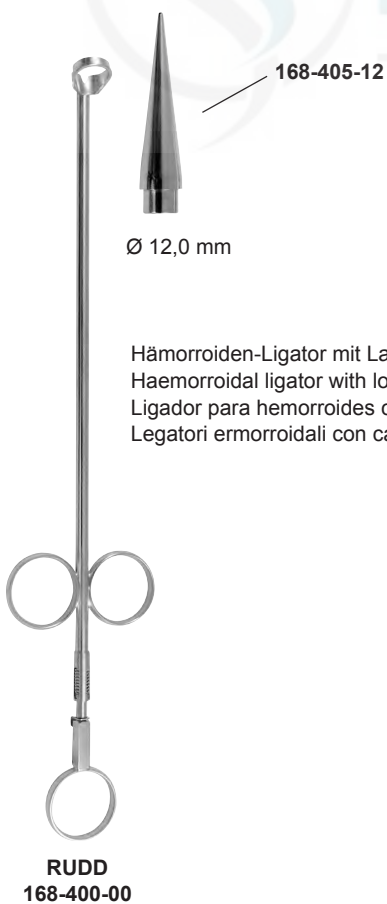

Hämorrhoiden-Faßzangen, Fistelsonden  
Haemorrhoidal Forceps, Fistula probes  
Pinza-clamps para hemorroides, Sondas para fistula  
Pinze per emorroidi, Sonde per fistola

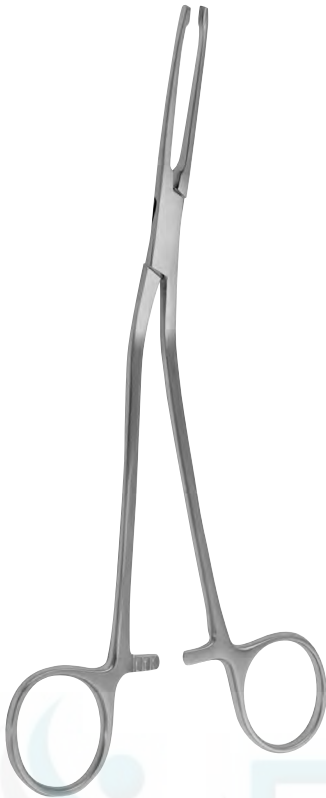

**MC GIVNEY**  
19,0 cm, 7<sup>1</sup>/<sub>2</sub>"  
168-471-19



**MC GIVNEY**  
19,0 cm, 7<sup>1</sup>/<sub>2</sub>"  
168-473-19



**PRATT**  
21,0 cm, 8<sup>1</sup>/<sub>4</sub>"



080-135-01



080-135-02



080-135-03

**Gynäkologie, Geburtshilfe**  
**Gynecology, Obstetrics**  
**Ginecología, Obstetricia**  
**Ginecologia, Ostetricia**

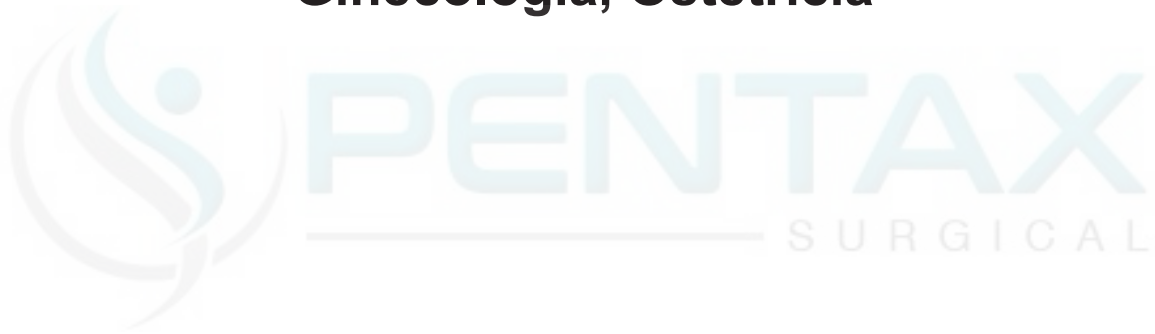

Scheidenspekula  
Vaginal Specula  
Espéculos vaginales  
Speculi vaginali

für Jungfrauen  
for virgins  
para virgenes  
per vergini



**COLLIN**  
65 x 10 mm  
180-132-00

für Kinder  
for children  
para niños  
per bambini



**COLLIN**  
65 x 10 mm  
180-134-00

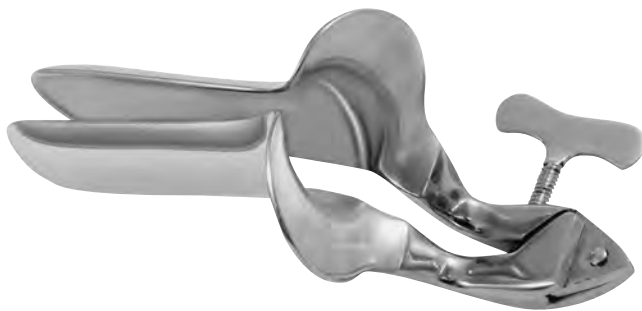

**COLLIN**

85 x 30 mm	<b>180-130-01</b>
100 x 35 mm	<b>180-130-02</b>
110 x 40 mm	<b>180-130-03</b>



80 x 24 mm	<b>180-142-01</b>
80 x 32 mm	<b>180-142-02</b>
98 x 16 mm	<b>180-142-03</b>
105 x 25 mm	<b>180-142-04</b>
107 x 29 mm	<b>180-142-05</b>
115 x 35 mm	<b>180-142-06</b>

zentrale Stellschraube  
central fixation screw  
tornillo de sujeto central  
vite di regolazione centrale



**CUSCO**

75 x 32 mm	<b>180-144-01</b>
85 x 36 mm	<b>180-144-02</b>
95 x 37 mm	<b>180-144-03</b>

seitliche Stellschraube  
lateral fixation screw  
tornillo de sujeto lateral  
vite di regolazione laterale



für Jungfrauen  
for virgins  
para virgenes  
per vergini

**CUSCO**  
75 x 17 mm  
**180-140-00**

seitliche Stellschraube  
lateral fixation screw  
tornillo de sujeto lateral  
vite di regolazione laterale



**CUSCO**

75 x 32 mm	<b>180-140-01</b>
85 x 35 mm	<b>180-140-02</b>
100 x 35 mm	<b>180-140-03</b>

Schweizer Modell  
Swiss pattern  
Modelo suizo  
Modello svizzero



**CUSCO**

90 x 23-25 mm	<b>180-146-01</b>
100 x 25-27 mm	<b>180-146-02</b>
110 x 27-30 mm	<b>180-146-03</b>

Scheidenspekula  
Vaginal Specula  
Especúlos vaginales  
Speculi vaginali



**GRAVE**

75 x 20 mm	<b>180-100-01</b>
95 x 35 mm	<b>180-100-02</b>
115 x 35 mm	<b>180-100-03</b>



**PEDERSON**

75 x 13 mm	<b>180-120-01</b>
100 x 22 mm	<b>180-120-02</b>
120 x 25 mm	<b>180-120-03</b>



**SEMM**

90 x 14-18 mm	<b>180-150-01</b>
100 x 17-20 mm	<b>180-150-02</b>
100 x 25-30 mm	<b>180-150-03</b>



**WEISSBARTH**  
21,0 cm, 8<sup>1</sup>/<sub>4</sub>"  
**180-160-00**



mit abnehmbarem Gewicht  
with detachable weight  
con peso desmontable  
con peso smontabile

1,14 kg

**AUVARD**  
75 x 38 mm  
180-170-00



mit festem Gewicht  
with fixed weight  
con peso fijo  
con peso fisso

1,14 kg

**AUVARD**  
75 x 38 mm  
180-172-00

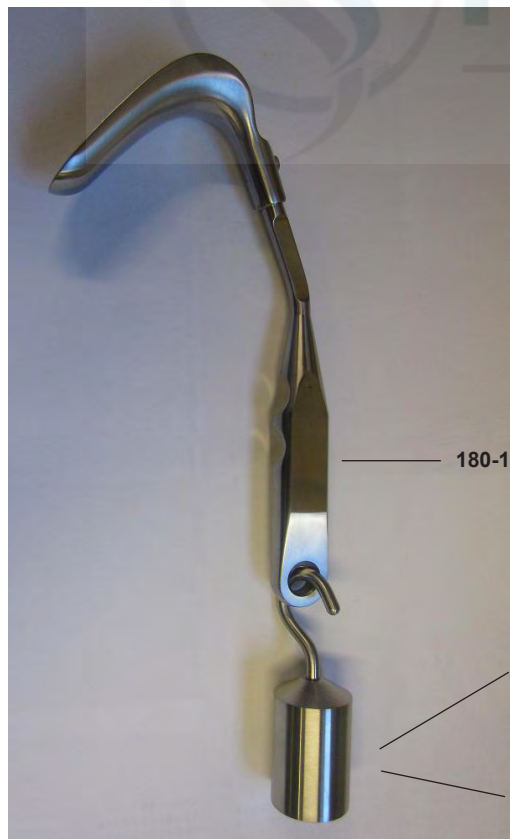

180-180-03

400 g  
180-180-40

800 g  
180-180-80

**SCHERBACK**  
180-180-00

koplett, complete, completo, completo

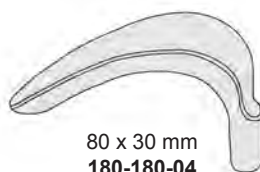

80 x 30 mm  
180-180-04

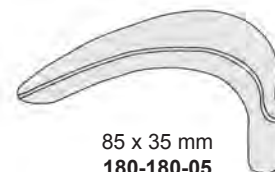

85 x 35 mm  
180-180-05

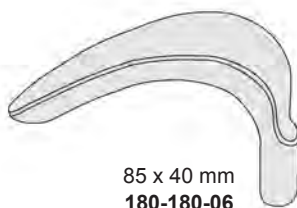

85 x 40 mm  
180-180-06

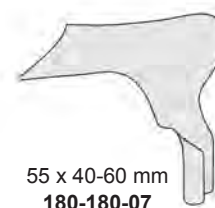

55 x 40-60 mm  
180-180-07



70 x 45-70 mm  
180-180-08



Satz  
Set  
Juego  
Set

**KRISTELLER**

Fig. 1 **180-220-01**  
Fig. 2 **180-220-02**  
Fig. 3 **180-220-03**



Spekula allein, flach  
Specula only, flat hollow  
Espéculos suelto, con huecos planos  
Solo speculi, piatta

**KRISTELLER**

105 x 26 mm **180-221-01**  
105 x 28 mm **180-221-02**  
105 x 33 mm **180-221-03**

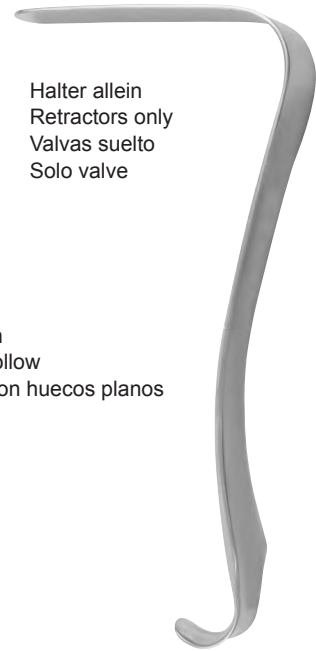

Halter allein  
Retractors only  
Valvas suelto  
Solo valve

**KRISTELLER**

115 x 22 mm **180-222-01**  
115 x 24 mm **180-222-02**  
115 x 29 mm **180-222-03**



Satz  
Set  
Juego  
Set

**KRISTELLER**

Fig. 1 **180-230-01**  
Fig. 2 **180-230-02**  
Fig. 3 **180-230-03**

Spekula allein, flach  
Specula only, flat hollow  
Espéculos suelto, con huecos planos  
Solo speculi, piatta

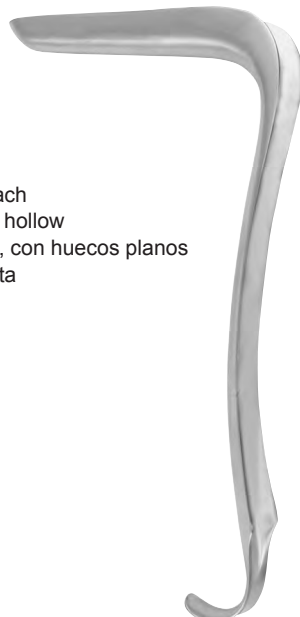

**KRISTELLER**

110 x 27 mm **180-231-01**  
110 x 30 mm **180-231-02**  
110 x 36 mm **180-231-03**



Halter allein  
Retractors only  
Valvas suelto  
Solo valve

**KRISTELLER**

115 x 23 mm **180-232-01**  
115 x 26 mm **180-232-02**  
115 x 32 mm **180-232-03**



Satz  
Set  
Juego  
Set

**KRISTELLER**  
Fig. 0 **180-234-00**  
Fig. 1 **180-234-01**  
Fig. 2 **180-234-02**  
Fig. 3 **180-234-03**



Spekula allein  
Specula only  
Espéculos suelto  
Solo speculi

**KRISTELLER**  
70 x 15 mm **180-235-00**  
70 x 27 mm **180-235-01**  
80 x 30 mm **180-235-02**  
90 x 36 mm **180-235-03**



Halter allein  
Retractors only  
Valvas suelto  
Solo valve

**KRISTELLER**  
75 x 10 mm **180-236-00**  
75 x 23 mm **180-236-01**  
85 x 26 mm **180-236-02**  
100 x 32 mm **180-236-03**



konisch, für Jungfrauen  
conical blades, for virgins  
valvas cónicas, para vírgenes  
valve coniche, per vergini

**KRISTELLER**  
Fig. 00 **180-237-01**  
Fig. 0 **180-237-02**

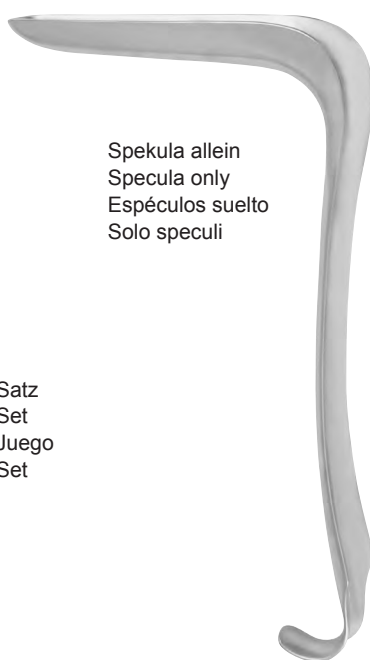

Spekula allein  
Specula only  
Espéculos suelto  
Solo speculi

Satz  
Set  
Juego  
Set

**KRISTELLER**  
105 x 18 mm **180-238-01**  
105 x 21 mm **180-238-02**

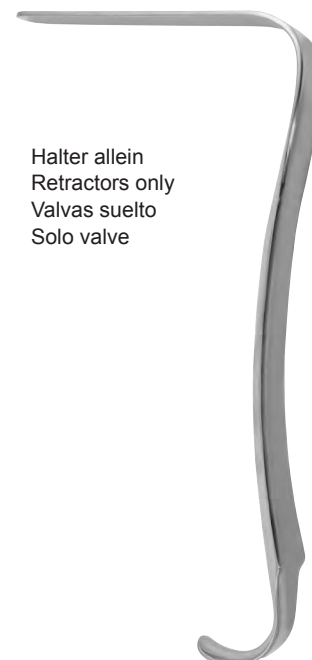

Halter allein  
Retractors only  
Valvas suelto  
Solo valve

**KRISTELLER**  
110 x 14 mm **180-239-01**  
110 x 17 mm **180-239-02**

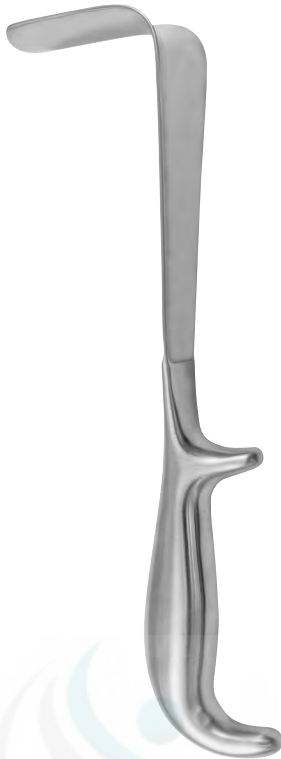

leicht hohl  
slightly-concave  
ligeremente concavos  
leggeremente concavi

Fig	a x b	
1	55 x 35 mm	<b>180-260-01</b>
2	85 x 35 mm	<b>180-260-02</b>
3	115 x 35 mm	<b>180-260-03</b>

1	55 x 45 mm	<b>180-261-01</b>
2	85 x 45 mm	<b>180-261-02</b>
3	115 x 45 mm	<b>180-261-03</b>
4	160 x 45 mm	<b>180-261-04</b>

1	55 x 60 mm	<b>180-262-01</b>
2	85 x 60 mm	<b>180-262-02</b>
3	115 x 60 mm	<b>180-262-03</b>
4	160 x 60 mm	<b>180-262-04</b>

**DOYEN**  
23,0 cm, 9"



halb-hohl  
medium-concave  
semi-concavos  
semi-concavi

Fig	a x b	
1	55 x 35 mm	<b>180-264-01</b>
2	85 x 35 mm	<b>180-264-02</b>
3	115 x 35 mm	<b>180-264-03</b>

1	55 x 45 mm	<b>180-265-01</b>
2	85 x 45 mm	<b>180-265-02</b>
3	115 x 45 mm	<b>180-265-03</b>

1	55 x 60 mm	<b>180-266-01</b>
2	85 x 60 mm	<b>180-266-02</b>
3	115 x 60 mm	<b>180-266-03</b>

**DOYEN**  
23,0 cm, 9"



Satz  
Set  
Juego  
Set

**KALLMORGEN**

70 x 40 mm	<b>180-270-01</b>
90 x 40 mm	<b>180-270-02</b>



Spekula allein  
Specula only  
Especúlos suelto  
Solo speculi

**KALLMORGEN**

70 x 40 mm	<b>180-271-01</b>
90 x 40 mm	<b>180-271-02</b>

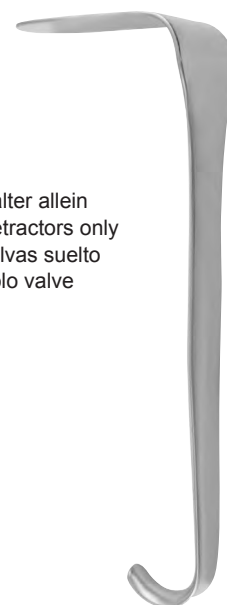

Halter allein  
Retractors only  
Valvas suelto  
Solo valve

**KALLMORGEN**

70 x 40 mm	<b>180-272-01</b>
90 x 40 mm	<b>180-272-02</b>



70 x 15 mm

**KRISTELLER**

17,0 cm, 6<sup>3</sup>/<sub>4</sub>"  
**180-275-17**

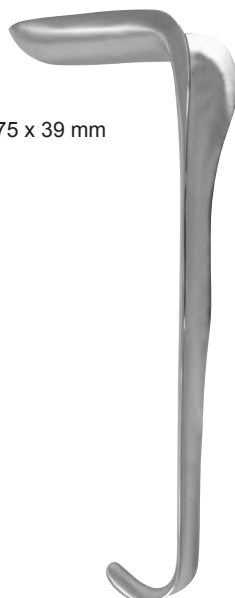

75 x 39 mm

**KALLMORGEN**

17,0 cm, 6<sup>3</sup>/<sub>4</sub>"  
**180-290-17**

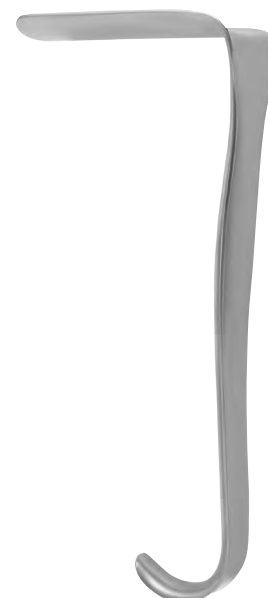

**JACKSON**

75 x 38 mm	<b>180-290-01</b>
90 x 38 mm	<b>180-290-02</b>
100 x 38 mm	<b>180-290-03</b>

Scheidenspekula  
Vaginal Specula  
Espéculos vaginales  
Speculi vaginali

76 x 25 mm



70 x 22 mm

**BREISKY**  
14,0 cm, 5½"  
180-292-01

82 x 30 mm



76 x 25 mm

**BREISKY**  
14,0 cm, 5½"  
180-292-02

95 x 38 mm

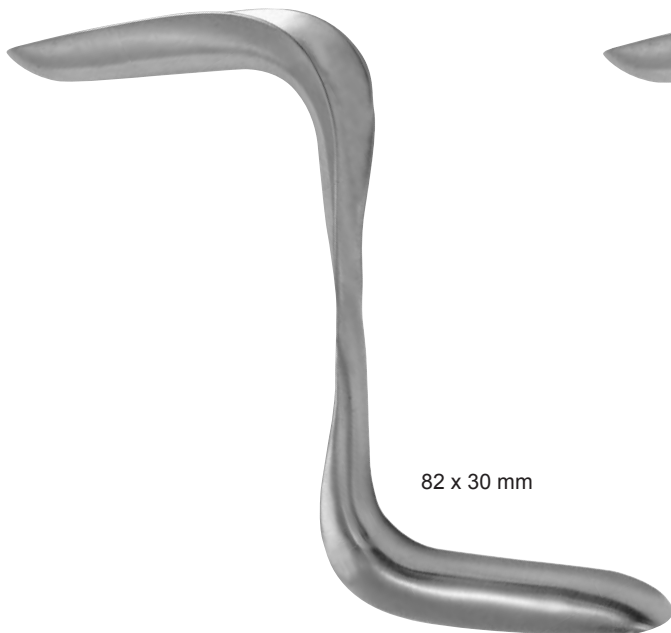

82 x 30 mm

**BREISKY**  
17,0 cm, 6¾"  
180-292-03

102 x 44 mm

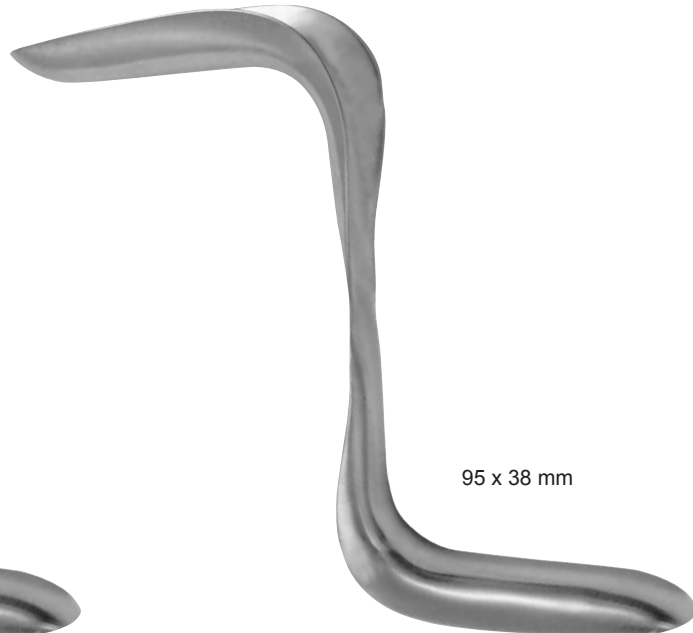

95 x 38 mm

**BREISKY**  
17,0 cm, 6¾"  
180-292-04

**SIMS**  
**57-8294-00**  
Satz, Set, Juego, Set, набор

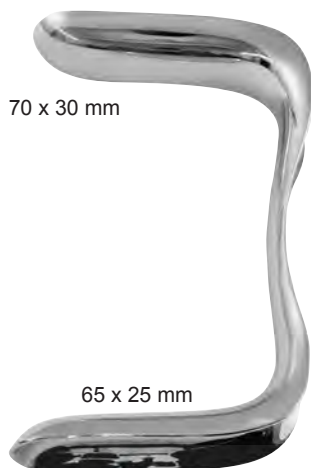

**SIMS**  
12,5 cm, 5"  
**180-294-01**

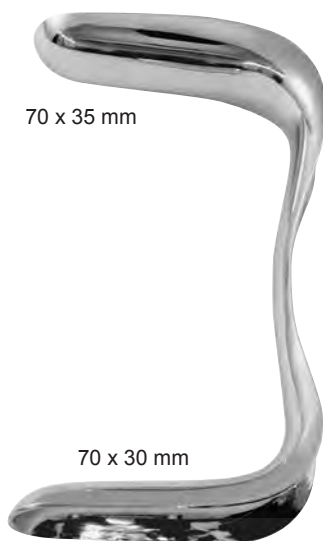

**SIMS**  
15,0 cm, 6"  
**180-294-02**

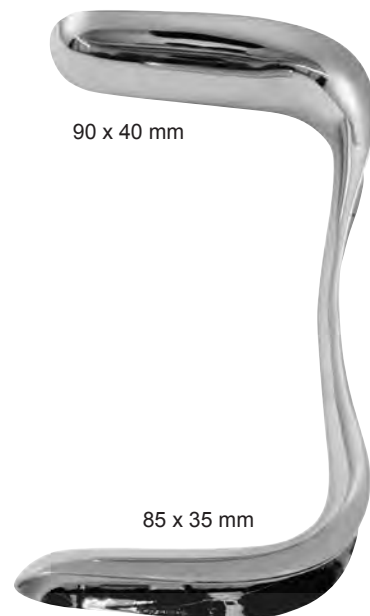

**SIMS**  
17,5 cm, 7"  
**180-294-03**

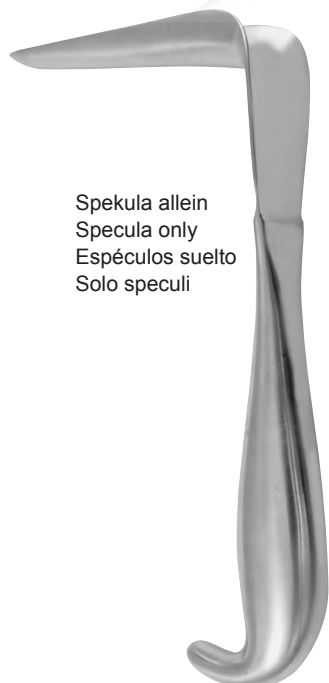

Spekula allein  
Specula only  
Espéculos suelto  
Solo speculi

**MATHIEU**  
100 x 13-23 mm **180-300-01**  
100 x 16-30 mm **180-300-02**



Halter allein  
Retractors only  
Valvas suelto  
Solo valve

**MATHIEU**  
100 x 11-21 mm **180-301-01**  
100 x 14-27 mm **180-301-02**



**LANDAU**  
100 x 28 mm **180-305-01**  
100 x 38 mm **180-305-02**

Scheidenspekula  
Vaginal Specula  
Espéculos vaginales  
Speculi vaginali



100 x 20 mm	<b>180-307-20</b>
100 x 25 mm	<b>180-307-25</b>
100 x 30 mm	<b>180-307-30</b>
100 x 35 mm	<b>180-307-35</b>
100 x 40 mm	<b>180-307-40</b>
<hr/>	
130 x 20 mm	<b>180-308-20</b>
130 x 25 mm	<b>180-308-25</b>
130 x 30 mm	<b>180-308-30</b>
130 x 35 mm	<b>180-308-35</b>
130 x 40 mm	<b>180-308-40</b>
<hr/>	
155 x 40 mm	<b>180-309-40</b>

**BREISKY**

85 x 17 mm



**BRAUN, MODIF.**  
19,0 cm, 7 1/2"  
**180-313-19**

60 x 30 mm



**DOYEN**  
23,0 cm, 9"  
**180-315-23**

80 x 30 mm



**DOYEN**  
25,0 cm, 9"  
**180-315-25**

95 x 38 mm



**WERTHEIM**  
30,0 cm, 12"  
**180-317-30**



3,0 mm

180-092-03

4,0 mm

180-092-04

5,0 mm

**KOGAN**  
24,0 cm, 9 1/2"

180-092-05



3,0 mm

180-090-03

4,0 mm

180-090-04

5,0 mm

**KOGAN**  
24,0 cm, 9 1/2"

180-090-05

Uterus-Dilatatoren  
 Uterine Dilators  
 Dilataores uterinos  
 Dilatatori uterini



**HEGAR**  
 18,5 cm, 7¼"

Ø 1,0 mm	<b>180-350-01</b>
Ø 2,0 mm	<b>180-350-02</b>
Ø 3,0 mm	<b>180-350-03</b>
Ø 4,0 mm	<b>180-350-04</b>
Ø 5,0 mm	<b>180-350-05</b>
Ø 6,0 mm	<b>180-350-06</b>
Ø 7,0 mm	<b>180-350-07</b>
Ø 8,0 mm	<b>180-350-08</b>
Ø 9,0 mm	<b>180-350-09</b>
Ø 10,0 mm	<b>180-350-10</b>
Ø 11,0 mm	<b>180-350-11</b>
Ø 12,0 mm	<b>180-350-12</b>
Ø 13,0 mm	<b>180-350-13</b>
Ø 14,0 mm	<b>180-350-14</b>
Ø 15,0 mm	<b>180-350-15</b>
Ø 16,0 mm	<b>180-350-16</b>
Ø 17,0 mm	<b>180-350-17</b>
Ø 18,0 mm	<b>180-350-18</b>
Ø 19,0 mm	<b>180-350-19</b>
Ø 20,0 mm	<b>180-350-20</b>
Ø 21,0 mm	<b>180-350-21</b>
Ø 22,0 mm	<b>180-350-22</b>
Ø 23,0 mm	<b>180-350-23</b>
Ø 24,0 mm	<b>180-350-24</b>
Ø 25,0 mm	<b>180-350-25</b>
Ø 26,0 mm	<b>180-350-26</b>



**HEGAR**  
 18,5 cm, 7¼"

Ø 1,5 mm	<b>180-351-01</b>
Ø 2,5 mm	<b>180-351-02</b>
Ø 3,5 mm	<b>180-351-03</b>
Ø 4,5 mm	<b>180-351-04</b>
Ø 5,5 mm	<b>180-351-05</b>
Ø 6,5 mm	<b>180-351-06</b>
Ø 7,5 mm	<b>180-351-07</b>
Ø 8,5 mm	<b>180-351-08</b>
Ø 9,5 mm	<b>180-351-09</b>
Ø 10,5 mm	<b>180-351-10</b>
Ø 11,5 mm	<b>180-351-11</b>
Ø 12,5 mm	<b>180-351-12</b>
Ø 13,5 mm	<b>180-351-13</b>
Ø 14,5 mm	<b>180-351-14</b>
Ø 15,5 mm	<b>180-351-15</b>
Ø 16,5 mm	<b>180-351-16</b>
Ø 17,5 mm	<b>180-351-17</b>



205 x 105 x 45 mm

**HEGAR**  
**180-350-99**  
 Satz, Set, Juego, Set  
 Ø 1,0 - Ø 26,0  
 (26 dilators)

**HEGAR**  
**180-350-98**  
 Satz, Set, Juego, Set  
 Ø 4,0 - Ø 17,0  
 (14 dilators)



**HEGAR**  
20,0 cm, 8"

Ø 1,0 / 2,0 mm	<b>180-354-01</b>
Ø 3,0 / 4,0 mm	<b>180-354-03</b>
Ø 5,0 / 6,0 mm	<b>180-354-05</b>
Ø 7,0 / 8,0 mm	<b>180-354-07</b>
Ø 9,0 / 10,0 mm	<b>180-354-09</b>
Ø 11,0 / 12,0 mm	<b>180-354-11</b>
Ø 13,0 / 14,0 mm	<b>180-354-13</b>
Ø 15,0 / 16,0 mm	<b>180-354-15</b>
Ø 17,0 / 18,0 mm	<b>180-354-17</b>
Ø 19,0 / 20,0 mm	<b>180-354-19</b>
Ø 21,0 / 22,0 mm	<b>180-354-21</b>
Ø 23,0 / 24,0 mm	<b>180-354-23</b>
Ø 25,0 / 26,0 mm	<b>180-354-25</b>



**HEGAR**  
**180-354-98**  
Satz, Set, Juego, Set  
Ø 3,0 / 4,0 - Ø 17,0 / 18,0 mm  
(8 dilators)

**HEGAR**  
**180-354-99**  
Satz, Set, Juego, Set  
Ø 1,0 / 2,0 - Ø 25,0 / 26,0 mm  
(13 dilators)



**HANK**

Ø 4,5 / 5,0 mm	<b>180-360-05</b>
Ø 5,5 / 6,0 mm	<b>180-360-06</b>
Ø 6,5 / 7,0 mm	<b>180-360-07</b>
Ø 7,5 / 8,0 mm	<b>180-360-08</b>
Ø 8,5 / 9,0 mm	<b>180-360-09</b>
Ø 9,5 / 10,0 mm	<b>180-360-10</b>



**HANK**  
**180-360-98**  
Satz, Set, Juego, Set  
Ø 4,5 / 5,0 - Ø 9,5 / 10,0 mm  
(6 dilators)

Uterus-Dilatatoren, Hakenzangen  
 Uterine Dilators, Uterine Tenaculum Forceps  
 Diladores uterinos, Pinzas para coger el cuello del útero  
 Dilatori uterini, Pinze per abbassare il collo dell'utero



PRATT

Ø 4,5 / 5,0 mm	<b>180-370-05</b>
Ø 5,5 / 6,0 mm	<b>180-370-06</b>
Ø 7,5 / 8,0 mm	<b>180-370-08</b>
Ø 8,5 / 9,0 mm	<b>180-370-09</b>
Ø 9,5 / 10,0 mm	<b>180-370-10</b>
Ø 11,5 / 12,0 mm	<b>180-370-12</b>
Ø 12,5 / 13,0 mm	<b>180-370-13</b>
Ø 13,5 / 14,0 mm	<b>180-370-14</b>

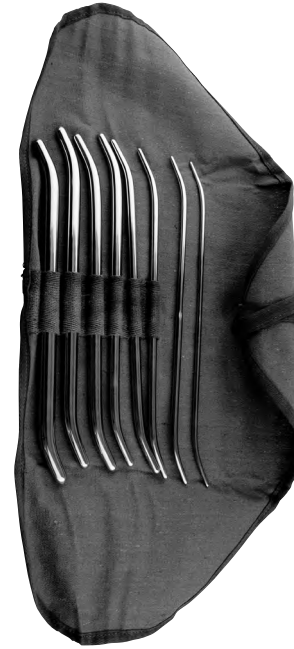

**PRATT**  
**180-370-98**  
 Satz, Set, Juego, Set  
 Ø 4,5 / 5,0 - Ø 13,5 / 14,0 mm  
 (8 dilators)



**BARRETT**  
 18,0 cm, 7"  
**180-410-18**



**ADAIR**  
 19,0 cm, 7 1/2"  
**180-412-19**



**STAUDE-MOORE**  
 17,0 cm, 6 3/4"  
**180-414-17**



**JARCHO**  
20,0 cm, 8"  
180-417-20



**SCHROEDER**  
25,0 cm, 9<sup>3</sup>/<sub>4</sub>"  
180-400-25



**BRAUN**  
25,0 cm, 9<sup>3</sup>/<sub>4</sub>"  
180-404-25

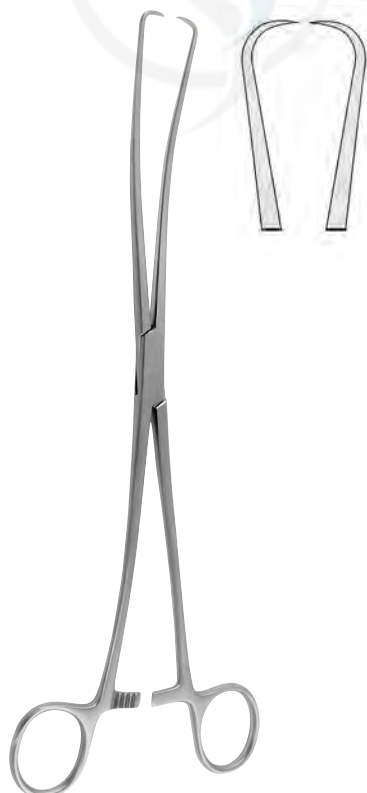

**DUPLAY**  
28,0 cm, 11"  
180-419-28



**POZZI**  
26,0 cm, 10<sup>1</sup>/<sub>4</sub>"  
180-402-26



**KAHN**  
24,0 cm, 9<sup>1</sup>/<sub>2</sub>"  
180-421-24

Hakenzangen  
Uterine Tenaculum Forceps  
Pinzas para coger el cuello del útero  
Pinze per abbassare il collo dell'utero



**SKENE**  
24,0 cm, 9½"  
180-423-24



**SCHROEDER**  
24,0 cm, 9½"  
180-426-24



**SCHROEDER**  
24,0 cm, 9½"  
180-429-24



**TEALE**  
23,0 cm, 9"  
180-431-23



**JACOBS**  
21,0 cm, 8½"  
180-434-21



**JACOBS**  
21,0 cm, 8½"  
180-435-21

Hakenzangen  
 Uterine Tenaculum Forceps  
 Pinzas para coger el cuello del útero  
 Pinze per abbassare il collo dell'utero



**MUSEUX**  
 24,0 cm, 9½"



**MUSEUX**  
 24,0 cm, 9½"



**BRAUN**  
 15,5 cm, 6"  
 180-442-15



**CZERNY**  
 20,5 cm, 8"  
 180-444-20



**PRATT**  
 28,0 cm, 11"  
 180-446-28



**IOWA**  
 26,0 cm, 10¼"  
 180-449-26

Polypen- und Ovarienzangen, Uterusfaßzangen  
 Polypus and Ovum Forceps, Uterine Elevating Forceps  
 Pinzas para pólipos uterinos y ovarios, Pinzas para la útero  
 Pinze per polipi e ovaie, Pinze per affarrare l'utero



**DOYEN**  
 20,5 cm, 8"  
 180-470-20

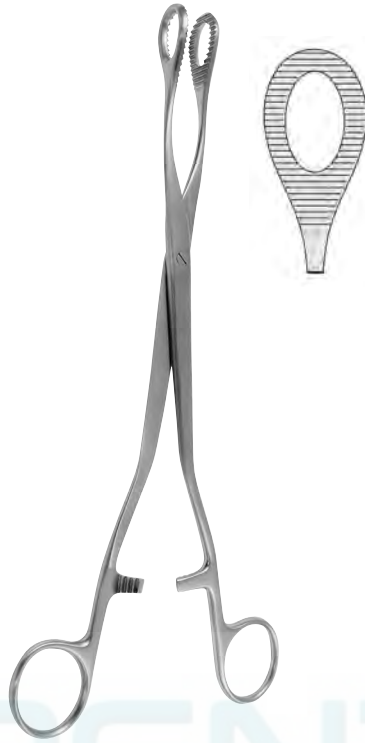

**NOTO**  
 27,0 cm, 10<sup>5</sup>/<sub>8</sub>"  
 180-472-27

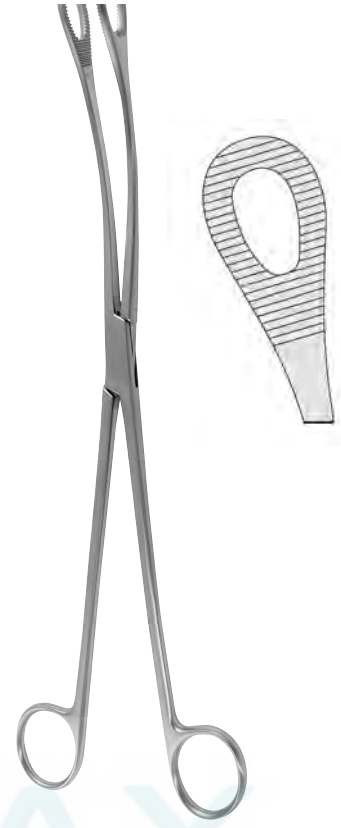

**KELLY**  
 32,0 cm, 12<sup>1</sup>/<sub>2</sub>"  
 180-475-32



**HEYWOOD-SMITH**  
 25,0 cm, 9<sup>3</sup>/<sub>4</sub>"  
 180-480-25



**DARTIGUES**  
 27,0 cm, 10<sup>3</sup>/<sub>4</sub>"  
 180-482-27



**SOMER**  
 23,0 cm, 9"  
 180-485-23



**COLLIN**  
25,0 cm, 9<sup>3</sup>/<sub>4</sub>"  
180-488-25



**BEACHAM**  
26,0 cm, 10<sup>1</sup>/<sub>4</sub>"  
180-500-26

Amniotom  
Amniotome  
Amniótomo  
Amniotomo



**BRAUN**  
28,0 cm, 11"  
180-502-28

Uterus-Depressor  
Uterine depressor  
Depresor uterino  
Depressori uterini



**SIMS**  
32,0 cm, 12<sup>1</sup>/<sub>2</sub>"  
180-510-32



**SIMS**  
32,0 cm, 12<sup>1</sup>/<sub>2</sub>"  
180-511-32

biegsam  
malleable  
maleable  
malleabile



**MARTIN**  
32,0 cm, 12<sup>1</sup>/<sub>2</sub>"  
180-516-32



**MARTIN**  
32,0 cm, 12<sup>1</sup>/<sub>2</sub>"  
180-518-32

biegsam  
malleable  
maleable  
malleabile



**VALLEIX**  
25,0 cm, 10"  
180-521-25



**SIMPSON**  
29,0 cm, 11<sup>1</sup>/<sub>2</sub>"  
180-527-29

biegsam  
malleable  
maleable  
malleabile



**COLLIN**  
28,0 cm, 11"  
180-529-28

Ø 4 mm

Biopsieküretten  
 Biopsy Currettes  
 Curetas para biopsia  
 Curette per biopsia



**KEVORKIAN**  
 30,0 cm, 12"  
 180-540-30



**KEVORKIAN**  
 30,0 cm, 12"  
 180-542-30



**KEVORKIAN**  
 30,0 cm, 12"  
 180-543-30

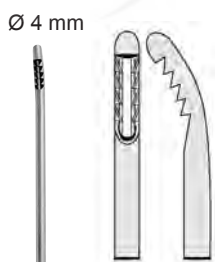

**NOVAK**  
 23,0 cm, 9"  
 180-550-04

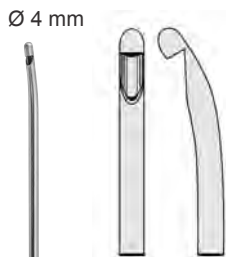

**RANDALL**  
 23,0 cm, 9"  
 180-552-04



**MILAN**  
 29,0 cm, 11 1/2"

Ø 4 mm  
 180-560-04

Ø 6 mm  
 180-560-06

Ø 9 mm  
 180-560-09



25,0 cm, 9<sup>3</sup>/<sub>4</sub>"  
180-570-25



25,0 cm, 9<sup>3</sup>/<sub>4</sub>"  
180-572-25



**SIMON**  
22,0 cm, 8<sup>5</sup>/<sub>8</sub>"  
180-574-22



180-576-01



180-576-02



180-576-03



180-576-04



180-576-05

**EMMETT**  
22,0 cm, 8<sup>5</sup>/<sub>8</sub>"



**SEGOND**  
27,0 cm, 10<sup>5</sup>/<sub>8</sub>"  
180-580-27

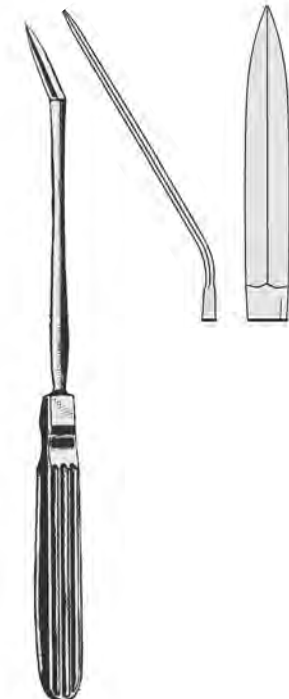

**AYRE**  
23,0 cm, 9"  
180-583-23



**DOYEN**  
19,0 cm, 7<sup>1</sup>/<sub>2</sub>"  
180-588-01



**DOYEN**  
17,0 cm, 6<sup>3</sup>/<sub>4</sub>"  
180-588-02



5 mm  
Fig. 00



6 mm  
Fig. 0



7 mm  
Fig. 1



8 mm  
Fig. 2



9 mm  
Fig. 3



11 mm  
Fig. 4



12 mm  
Fig. 5



14 mm  
Fig. 6



15 mm  
Fig. 7



16 mm  
Fig. 8



19 mm  
Fig. 9



20 mm  
Fig. 10



21 mm  
Fig. 11



23 mm  
Fig. 12



scharf, fest  
 sharp, rigid  
 cortantes, rígidas  
 acute, rigide

Fig. 00	180-700-05
Fig. 0	180-700-06
Fig. 1	180-700-07
Fig. 2	180-700-08
Fig. 3	180-700-09
Fig. 4	180-700-11
Fig. 5	180-700-12
Fig. 6	180-700-14
Fig. 7	180-700-15
Fig. 8	180-700-16
Fig. 9	180-700-19
Fig. 10	180-700-20
Fig. 11	180-700-21
Fig. 12	180-700-23

**RECAMIER**  
 26,0 cm, 10<sup>1</sup>/<sub>4</sub>"



scharf, biegsam  
 sharp, malleable  
 cortantes, maleable  
 acute, malleabile

Fig. 00	180-701-05
Fig. 0	180-701-06
Fig. 1	180-701-07
Fig. 2	180-701-08
Fig. 3	180-701-09
Fig. 4	180-701-11
Fig. 5	180-701-12
Fig. 6	180-701-14
Fig. 7	180-701-15
Fig. 8	180-701-16
Fig. 9	180-701-19
Fig. 10	180-701-20
Fig. 11	180-701-21
Fig. 12	180-701-23

**RECAMIER**  
 26,0 cm, 10<sup>1</sup>/<sub>4</sub>"

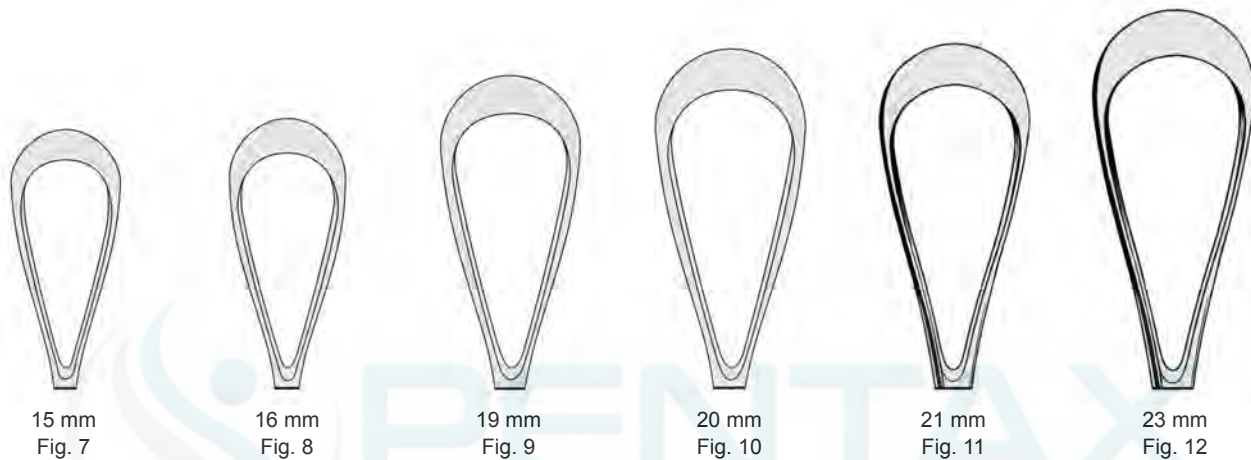
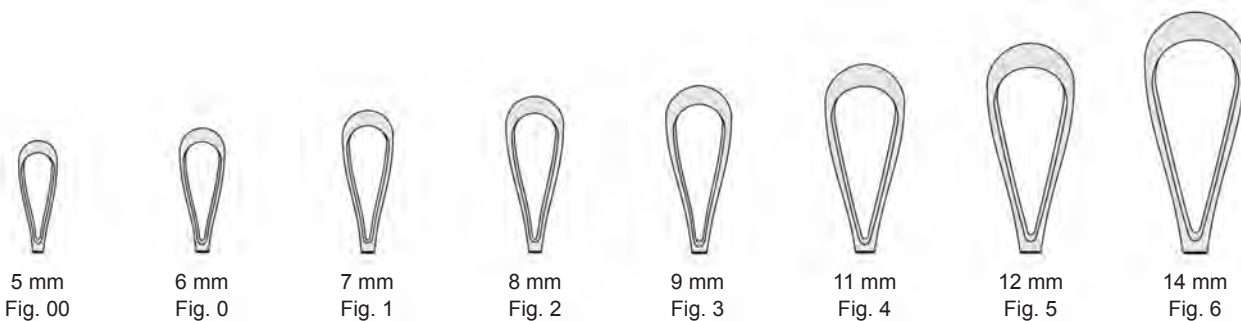

scharf, fest  
sharp, rigid  
cortantes, rígidas  
acute, rigide

Fig. 00	180-702-05
Fig. 0	180-702-06
Fig. 1	180-702-07
Fig. 2	180-702-08
Fig. 3	180-702-09
Fig. 4	180-702-11
Fig. 5	180-702-12
Fig. 6	180-702-14
Fig. 7	180-702-15
Fig. 8	180-702-16
Fig. 9	180-702-19
Fig. 10	180-702-20
Fig. 11	180-702-21
Fig. 12	180-702-23

**SIMS**  
26,0 cm, 10 1/4"



scharf, biegsam  
sharp, malleable  
cortantes, maleable  
acute, malleabile

Fig. 00	180-703-05
Fig. 0	180-703-06
Fig. 1	180-703-07
Fig. 2	180-703-08
Fig. 3	180-703-09
Fig. 4	180-703-11
Fig. 5	180-703-12
Fig. 6	180-703-14
Fig. 7	180-703-15
Fig. 8	180-703-16
Fig. 9	180-703-19
Fig. 10	180-703-20
Fig. 11	180-703-21
Fig. 12	180-703-23

**SIMS**  
26,0 cm, 10 1/4"



5 mm  
Fig. 00



6 mm  
Fig. 0



7 mm  
Fig. 1



8 mm  
Fig. 2



9 mm  
Fig. 3



11 mm  
Fig. 4



12 mm  
Fig. 5



14 mm  
Fig. 6



15 mm  
Fig. 7



16 mm  
Fig. 8

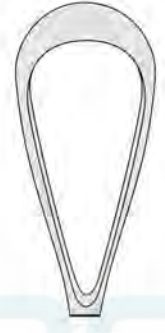

19 mm  
Fig. 9



20 mm  
Fig. 10



21 mm  
Fig. 11



23 mm  
Fig. 12



scharf, fest  
 sharp, rigid  
 cortantes, rígidas  
 acute, rigide

Fig. 00	180-710-05
Fig. 0	180-710-06
Fig. 1	180-710-07
Fig. 2	180-710-08
Fig. 3	180-710-09
Fig. 4	180-710-11
Fig. 5	180-710-12
Fig. 6	180-710-14
Fig. 7	180-710-15
Fig. 8	180-710-16
Fig. 9	180-710-19
Fig. 10	180-710-20
Fig. 11	180-710-21
Fig. 12	180-710-23

**RECAMIER**  
 31,0 cm, 12<sup>1</sup>/<sub>4</sub>"



scharf, biegsam  
 sharp, malleable  
 cortantes, maleable  
 acute, malleabile

Fig. 00	180-711-05
Fig. 0	180-711-06
Fig. 1	180-711-07
Fig. 2	180-711-08
Fig. 3	180-711-09
Fig. 4	180-711-11
Fig. 5	180-711-12
Fig. 6	180-711-14
Fig. 7	180-711-15
Fig. 8	180-711-16
Fig. 9	180-711-19
Fig. 10	180-711-20
Fig. 11	180-711-21
Fig. 12	180-711-23

**RECAMIER**  
 31,0 cm, 12<sup>1</sup>/<sub>4</sub>"



scharf, fest  
sharp, rigid  
cortantes, rígidas  
acute, rigide

Fig. 00	180-712-05
Fig. 0	180-712-06
Fig. 1	180-712-07
Fig. 2	180-712-08
Fig. 3	180-712-09
Fig. 4	180-712-11
Fig. 5	180-712-12
Fig. 6	180-712-14
Fig. 7	180-712-15
Fig. 8	180-712-16
Fig. 9	180-712-19
Fig. 10	180-712-20
Fig. 11	180-712-21
Fig. 12	180-712-23

**SIMS**  
31,0 cm, 12<sup>1</sup>/<sub>4</sub>"



scharf, biegsam  
sharp, malleable  
cortantes, maleable  
acute, malleabile

Fig. 00	180-713-05
Fig. 0	180-713-06
Fig. 1	180-713-07
Fig. 2	180-713-08
Fig. 3	180-713-09
Fig. 4	180-713-11
Fig. 5	180-713-12
Fig. 6	180-713-14
Fig. 7	180-713-15
Fig. 8	180-713-16
Fig. 9	180-713-19
Fig. 10	180-713-20
Fig. 11	180-713-21
Fig. 12	180-713-23

**SIMS**  
31,0 cm, 12<sup>1</sup>/<sub>4</sub>"

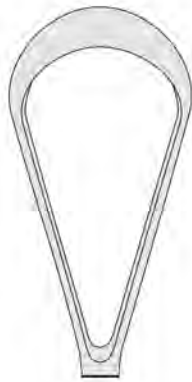

30 mm  
 Fig. 1

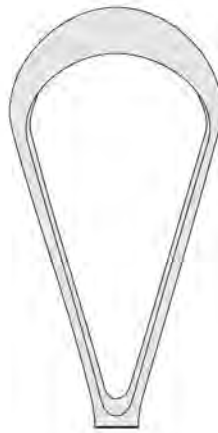

35 mm  
 Fig. 2

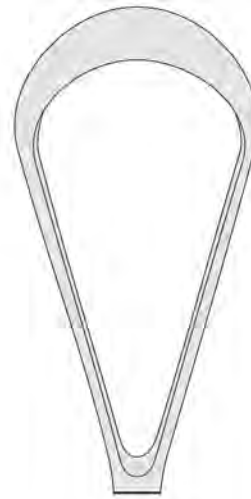

40 mm  
 Fig. 3



scharf, fest  
 sharp, rigid  
 cortantes, rígidas  
 acute, rigide

Fig. 1 **180-720-30**  
 Fig. 2 **180-720-35**  
 Fig. 3 **180-720-40**

**SIMS**  
 31,0 cm, 12<sup>1</sup>/<sub>4</sub>"



scharf, biegsam  
 sharp, malleable  
 cortantes, maleable  
 acute, malleabile

Fig. 1 **180-721-30**  
 Fig. 2 **180-721-35**  
 Fig. 3 **180-721-40**

**SIMS**  
 31,0 cm, 12<sup>1</sup>/<sub>4</sub>"

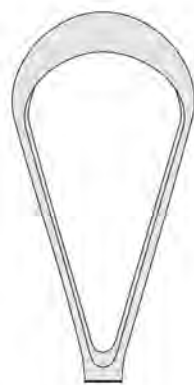

30 mm  
Fig. 1

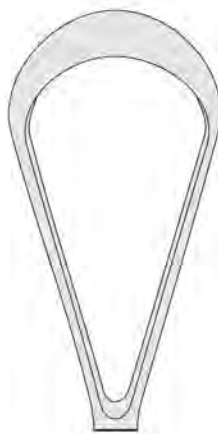

35 mm  
Fig. 2

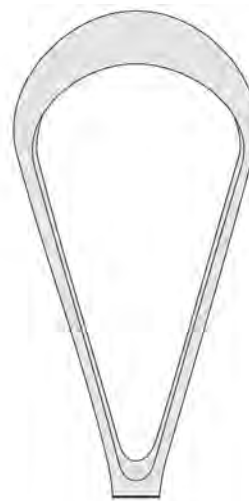

40 mm  
Fig. 3



**BUMM**  
31,0 cm, 12<sup>1</sup>/<sub>4</sub>"

scharf, fest  
sharp, rigid  
cortantes, rígidas  
acute, rigide

Fig. 1 **180-722-30**  
Fig. 2 **180-722-35**  
Fig. 3 **180-722-40**



**BUMM**  
31,0 cm, 12<sup>1</sup>/<sub>4</sub>"

scharf, biegsam  
sharp, malleable  
cortantes, maleable  
acute, malleabile

Fig. 1 **180-723-30**  
Fig. 2 **180-723-35**  
Fig. 3 **180-723-40**

Uteruslöffel, Uterus-Biopsiezangen  
 Uterine Scoopes, Cervical Biopsy and Specimen Forceps  
 Cucharillas uterinas, Pinzas saca-bocados para biopsia  
 Curette uterine, Pinze per la biopsia cervicale e da prelievo



**BLAKE**  
 27,0 cm, 10<sup>5</sup>/<sub>8</sub>"  
 180-750-27



**SIMON**  
 25,0 cm, 9<sup>3</sup>/<sub>4</sub>"

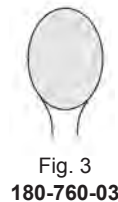

**THOMS-GAYLOR**  
 22,0 cm, 8<sup>5</sup>/<sub>8</sub>" 180-680-22  
 24,0 cm, 9<sup>1</sup>/<sub>2</sub>" 180-680-24



**SCHUBERT**  
 21,0 cm, 8<sup>1</sup>/<sub>4</sub>" 180-682-21  
 29,0 cm, 11<sup>1</sup>/<sub>2</sub>" 180-682-29

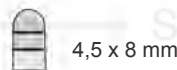

**SCHUMACHER-VAN DOREN**  
 24,0 cm, 9<sup>1</sup>/<sub>2</sub>"  
 180-684-24



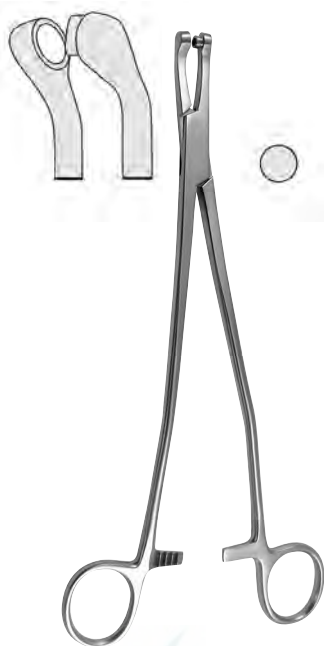

**THOMS-GAYLOR**  
24,0 cm, 9½"  
180-686-24



**FAURE**  
21,0 cm, 8¼"  
180-688-21

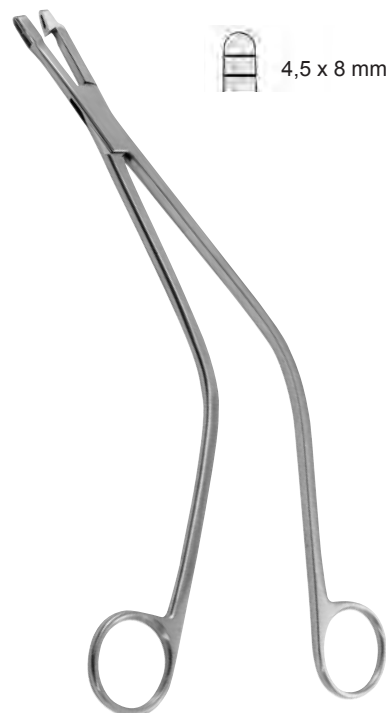

**SCHUBERT**  
26,0 cm, 10¼"  
180-690-26

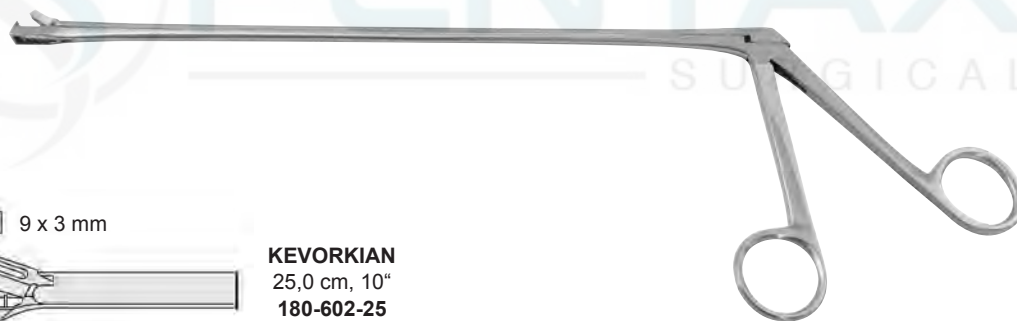

9 x 3 mm



**KEVORKIAN**  
25,0 cm, 10"  
180-602-25

4,5 x 8 mm

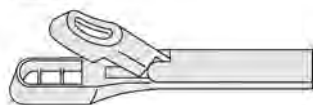

**EPPENDORFER**  
20,0 cm, 8"  
180-604-20

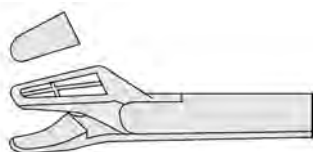

**ALEXANDER**  
28,0 cm, 11"  
180-608-28

4,0 mm

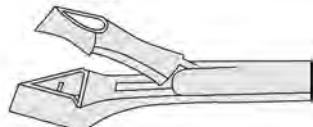

**SCHUMACHER**  
24,0 cm, 9½"  
180-610-04

6,0 mm

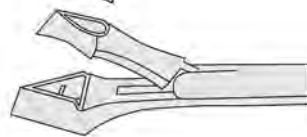

**SCHUMACHER**  
24,0 cm, 9½"  
180-610-06

4,5 x 8 mm



**WITNER**  
23,0 cm, 9"  
180-615-23

4,5 x 8 mm



**WITNER**  
23,0 cm, 9"  
180-614-23

Uterus-Biopsiezangen  
 Cervical Biopsy and Specimen Forceps  
 Pinzas saca-bocados para biopsia  
 Pinze per la biopsia cervicale e da prelievo

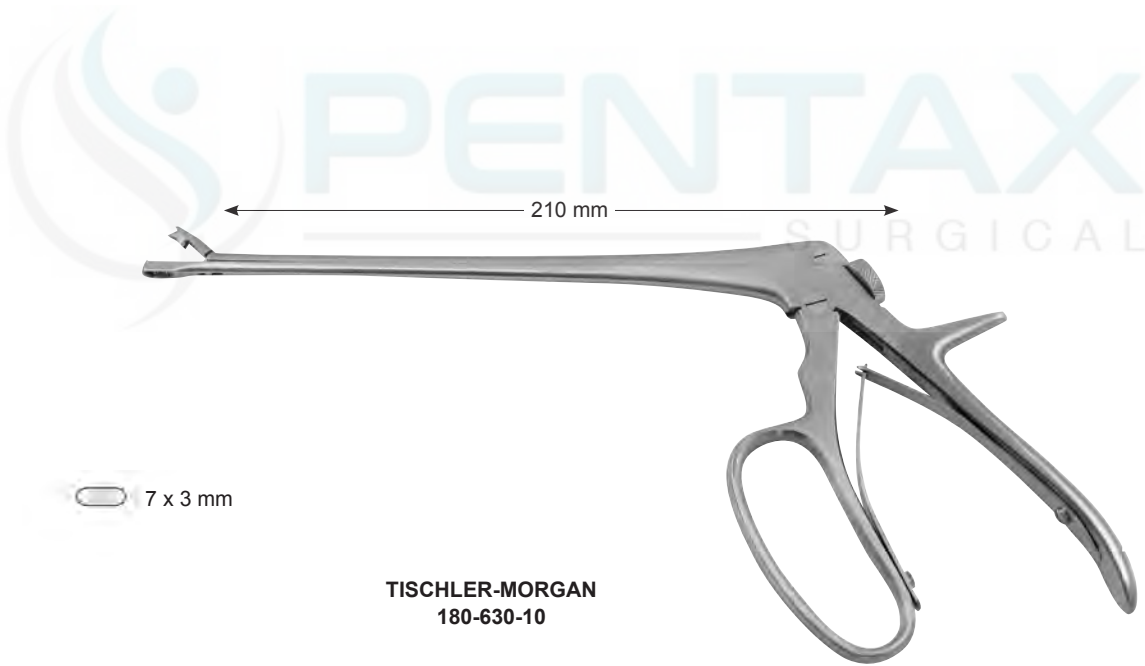
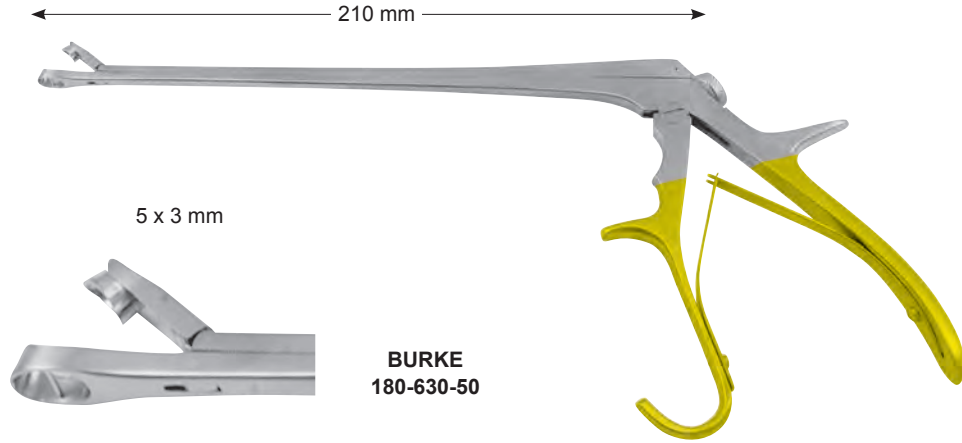

2,3 x 4 mm

**MINI-TOWNSEND**  
180-630-12

9 x 3 mm

**TISCHLER-KEVORKIAN**  
180-630-41

2,3 x 4 mm

**BABY-TISCHLER**  
180-630-14

9 x 3 mm

**KEVORKIAN-PACIFIC**  
180-630-40



**WRIGLEY**  
28,0 cm, 11"  
181-056-28



**SIMPSON**  
30,0 cm, 11<sup>3</sup>/<sub>4</sub>"  
181-034-30



**SIMPSON-BRAUN**  
33,0 cm, 13"  
181-036-33



**SIMPSON-BRAUN**  
36,0 cm, 14<sup>1</sup>/<sub>8</sub>"  
181-036-36



**SIMPSON-LUIKART**  
36,0 cm, 14<sup>1</sup>/<sub>8</sub>"  
181-046-36



**DE LEE**  
30,0 cm, 11<sup>3</sup>/<sub>4</sub>"  
181-058-30



**DE LEE**  
36,0 cm, 14<sup>1</sup>/<sub>8</sub>"  
181-058-36



**DE LEE**  
38,0 cm, 15<sup>3</sup>/<sub>8</sub>"  
181-058-38



**MC LEAN**  
36,0 cm, 14<sup>1</sup>/<sub>8</sub>"  
181-044-36



**KIELAND**  
41,0 cm, 16"  
181-052-41



**KIELAND-LUIKART**  
40,0 cm, 15<sup>3</sup>/<sub>4</sub>"  
181-054-40



**PIPER**  
44,0 cm, 17<sup>1</sup>/<sub>4</sub>"  
181-060-44



**ELLIOT**  
32,0 cm, 12<sup>1</sup>/<sub>2</sub>"  
181-080-32



**ELLIOT**  
38,0 cm, 15"  
181-080-38



**NAEGELE**  
36,0 cm, 14<sup>1</sup>/<sub>8</sub>"  
181-084-36



**NAEGELE**  
40,0 cm, 15<sup>3</sup>/<sub>4</sub>"  
181-084-40



**GREEN-ARMYTAGE**  
 21,0 cm, 8<sup>1</sup>/<sub>4</sub>"  
 181-200-21

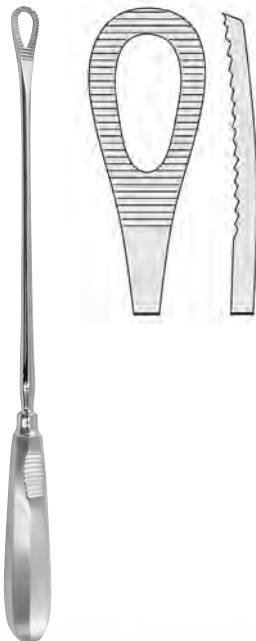

**PESTALOZZA**  
 30,0 cm, 11<sup>3</sup>/<sub>4</sub>"  
 181-252-30



**SAENGER**  
 27,0 cm, 10<sup>5</sup>/<sub>8</sub>"  
 181-260-27



**SAENGER**  
 27,0 cm, 10<sup>5</sup>/<sub>8</sub>"  
 181-261-27



**WINTER**  
 28,0 cm, 11"



Fig. 1  
 181-244-01



Fig. 2  
 181-244-02



Fig. 3  
 181-244-03



Fig. 1  
 181-245-01



Fig. 2  
 181-245-02



Fig. 3  
 181-245-03

Plazentar- und Abortuszangen  
 Placenta and Ovum Forceps  
 Pinzas para aborto y placenta  
 Pinze per placenta e per ovaie



**WALLICH**  
 42,0 cm, 16<sup>1</sup>/<sub>2</sub>"  
 181-300-42



**MARTIN**  
 34,0 cm, 13<sup>3</sup>/<sub>8</sub>"  
 181-600-34



gerade  
 straight  
 recto  
 retto

**BIERER**  
 33,0 cm, 13"  
 58-1236-01



gerade  
 straight  
 recto  
 retto

**BIERER**  
 33,0 cm, 13"  
 181-236-02

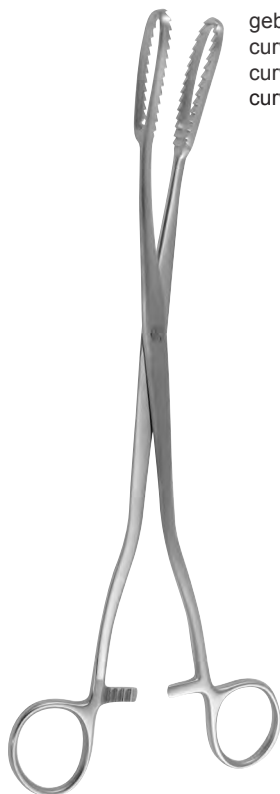

gebogen  
 curved  
 curvo  
 curvo

**BIERER**  
 33,0 cm, 13"  
 181-237-01



gebogen  
 curved  
 curvo  
 curvo

**BIERER**  
 33,0 cm, 13"  
 181-237-02

**Vorbereitung, Dermatologie**  
**Preparation, Dermatology**  
**Preparación, Dermatología**  
**Preparazione, Dermatalogia**

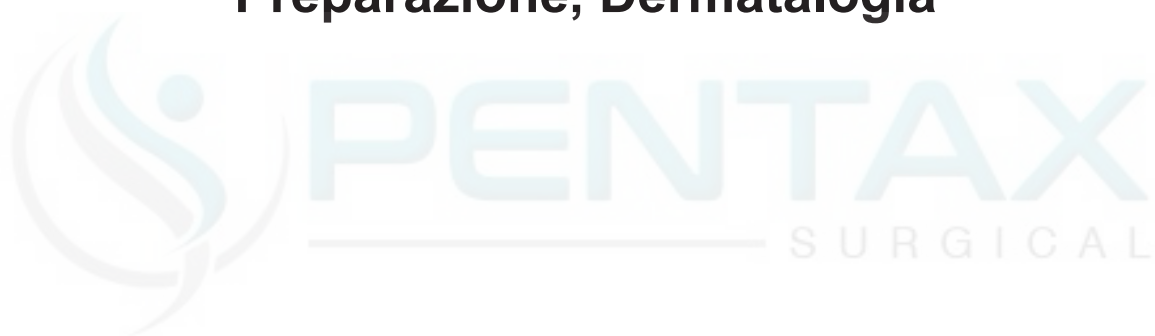



**PIFFARD**  
 14,0 cm, 5<sup>3</sup>/<sub>4</sub>"

Lupusküretten  
 Lupus cures  
 Curetas para lupus  
 Raschiatoio per lupus



**KEYES**  
 12,0 cm, 4<sup>3</sup>/<sub>4</sub>"

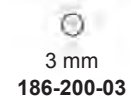
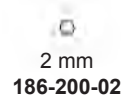

**KEYES**  
 12,0 cm, 4<sup>3</sup>/<sub>4</sub>"  
 186-210-00

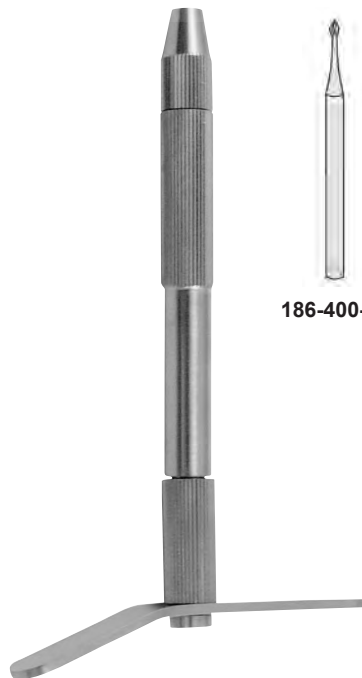

**186-400-00**  
 komplett, complete,  
 completo, completo,

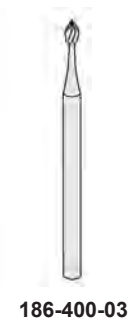



**UNNA**  
14,0 cm, 5<sup>3</sup>/<sub>4</sub>"  
186-000-14



**UNNA**  
14,0 cm, 5<sup>3</sup>/<sub>4</sub>"  
186-002-14



**SAALFELD**  
10,0 cm, 4"  
186-010-10



**SAALFELD**  
14,0 cm, 5<sup>3</sup>/<sub>4</sub>"  
186-012-14



**SCHAMBERG**  
10,0 cm, 4"  
186-020-10



**WALTON**  
14,0 cm, 5<sup>3</sup>/<sub>4</sub>"  
186-030-14



**FOX**  
14,0 cm, 5<sup>3</sup>/<sub>4</sub>"



Lupusküretten  
Lupus curettes  
Curetas para lupus  
Raschiatoio per lupus



186-420-01

17,0 cm, 6<sup>3</sup>/<sub>4</sub>"  
 186-420-17



186-430-01

WALTON  
 16,0 cm, 6<sup>1</sup>/<sub>4</sub>"  
 186-430-16



RADOLF  
 13,5 cm, 5<sup>3</sup>/<sub>8</sub>"  
 186-500-13



13,5 cm, 5<sup>3</sup>/<sub>8</sub>"  
 186-510-13



13,0 cm, 5"  
 186-600-13



14,0 cm, 5<sup>1</sup>/<sub>2</sub>"

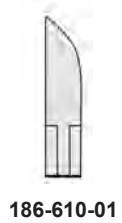

186-610-01



186-610-02

**Knochenchirurgie**  
**Bone Surgery**  
**Cirurgía ósea**  
**Chirurgia ossea**

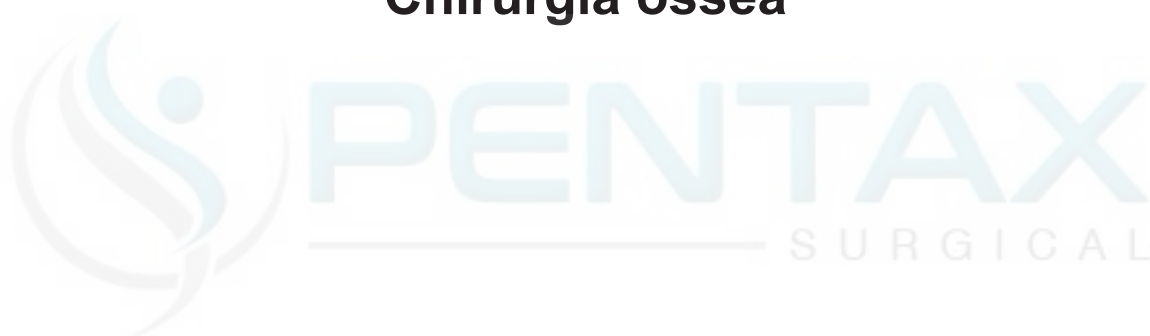

Scharfe Löffel  
Bone Curettes  
Cucharillas cortantes  
Curetta per ossa



**SCHEDE**  
17,0 cm, 6<sup>3</sup>/<sub>4</sub>"

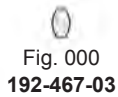

Fig. 000  
192-467-03

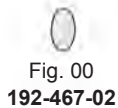

Fig. 00  
192-467-02



Fig. 0  
192-467-01



Fig. 1  
192-467-11



Fig. 2  
192-467-12

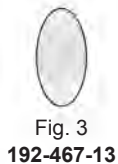

Fig. 3  
192-467-13



Fig. 4  
192-467-14



**VOLKMANN**  
17,0 cm, 6<sup>3</sup>/<sub>4</sub>"



Fig. 0000  
192-469-04

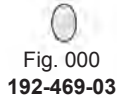

Fig. 000  
192-469-03



Fig. 00  
192-469-02



Fig. 0  
192-469-01



Fig. 1  
192-469-11



Fig. 2  
192-469-12

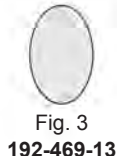

Fig. 3  
192-469-13

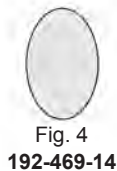

Fig. 4  
192-469-14

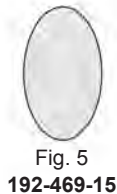

Fig. 5  
192-469-15



Fig. 6  
192-469-16



**BRUNS**  
17,0 cm, 6<sup>3</sup>/<sub>4</sub>"

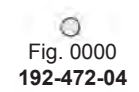

Fig. 0000  
192-472-04



Fig. 000  
192-472-03



Fig. 00  
192-472-02



Fig. 0  
192-472-01



Fig. 1  
192-472-11



Fig. 2  
192-472-12



Fig. 3  
192-472-13



Fig. 4  
192-472-14





Fig. 5  
192-472-15

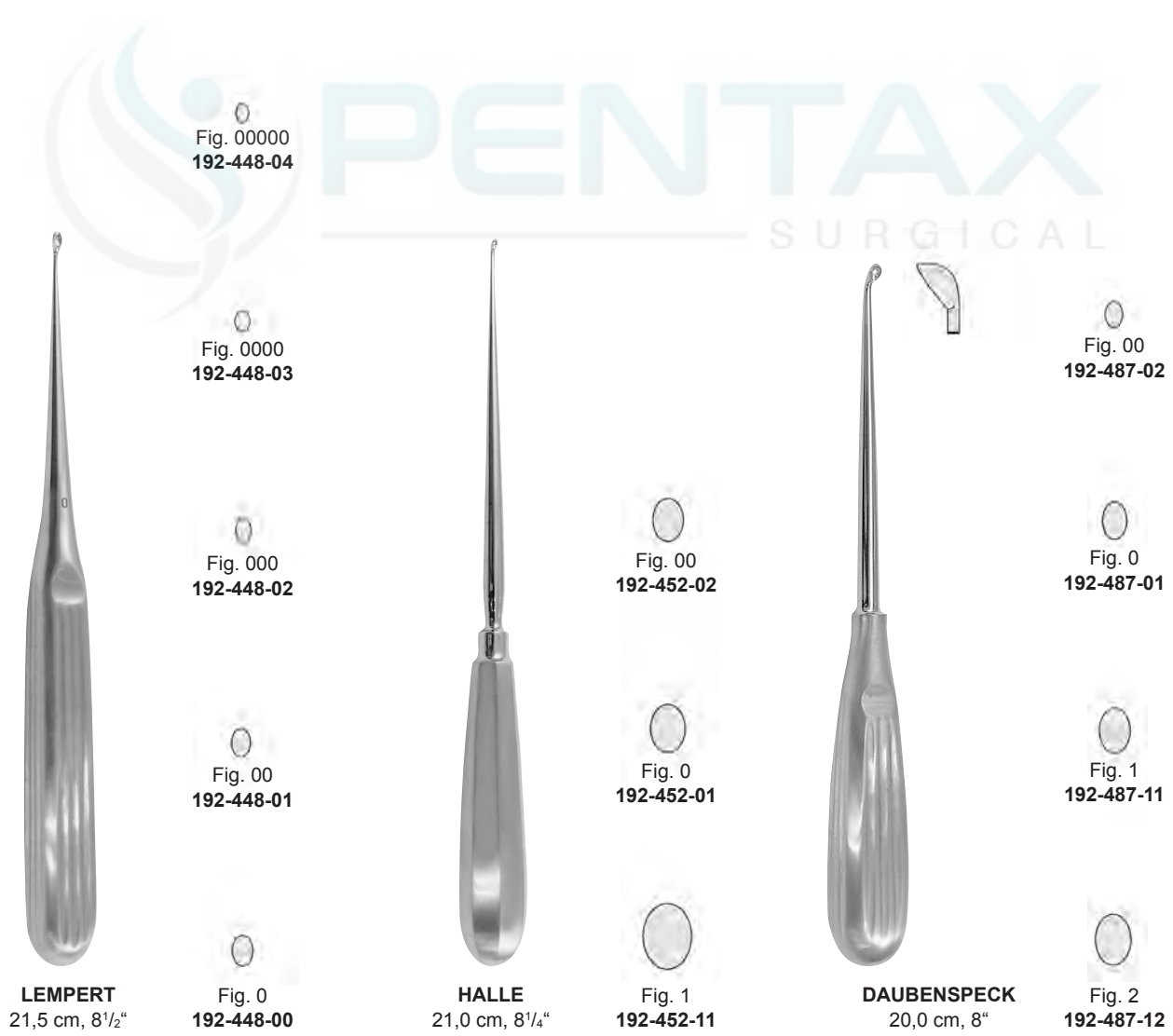

Fig. 6  
192-472-16



 <p><b>LEMPERT</b> 21,5 cm, 8½"</p>	 <p><b>HALLE</b> 21,0 cm, 8¼"</p>	 <p><b>DAUBENSPECK</b> 20,0 cm, 8"</p>
<p>Fig. 00000 192-448-04</p> <p>Fig. 0000 192-448-03</p> <p>Fig. 000 192-448-02</p> <p>Fig. 00 192-448-01</p> <p>Fig. 0 192-448-00</p>	<p>Fig. 00 192-452-02</p> <p>Fig. 0 192-452-01</p> <p>Fig. 1 192-452-11</p>	<p>Fig. 00 192-487-02</p> <p>Fig. 0 192-487-01</p> <p>Fig. 1 192-487-11</p> <p>Fig. 2 192-487-12</p>

Scharfe Löffel  
 Bone Currettes  
 Cucharillas cortantes  
 Curetta per ossa



**WILLIGER**  
 17,0 cm, 6<sup>3</sup>/<sub>4</sub>"



Fig. 1  
**192-430-11**

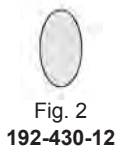

Fig. 2  
**192-430-12**



**WILLIGER**  
 14,0 cm, 5<sup>1</sup>/<sub>2</sub>"



Fig. 0  
**192-406-00**



Fig. 1  
**192-406-01**

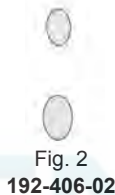

Fig. 2  
**192-406-02**



**MARTINI**  
 14,0 cm, 5<sup>1</sup>/<sub>2</sub>"  
**192-408-00**



Fig. 00/0  
**192-408-00**  
 14,0 cm, 5<sup>1</sup>/<sub>2</sub>"

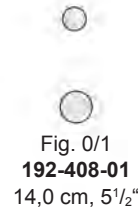

Fig. 0/1  
**192-408-01**  
 14,0 cm, 5<sup>1</sup>/<sub>2</sub>"



Fig. 1/2  
**192-408-12**  
 14,0 cm, 5<sup>1</sup>/<sub>2</sub>"



**VOLKMANN**

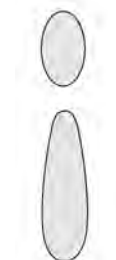

**192-414-13**  
 13,0 cm, 5"



**192-414-14**  
 14,0 cm, 5<sup>1</sup>/<sub>2</sub>"



**192-414-17**  
 17,0 cm, 6<sup>3</sup>/<sub>4</sub>"



**JANSEN**  
 16,0 cm, 6<sup>1</sup>/<sub>4</sub>"  
**192-410-16**



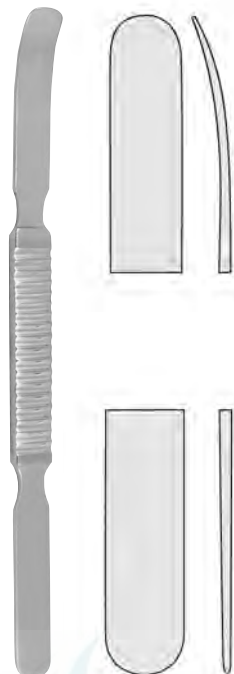

**WATSON-CHEYNE**  
17,5 cm, 6<sup>5</sup>/<sub>8</sub>"  
193-501-17



**MC DONALD**  
19,0 cm, 7<sup>1</sup>/<sub>2</sub>"  
193-440-19

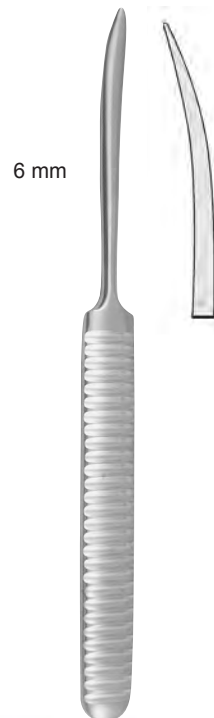

**WILLIGER**  
17,0 cm, 6<sup>3</sup>/<sub>4</sub>"  
193-512-17



**WILLIGER**  
16,0 cm, 6<sup>1</sup>/<sub>4</sub>"  
193-512-16

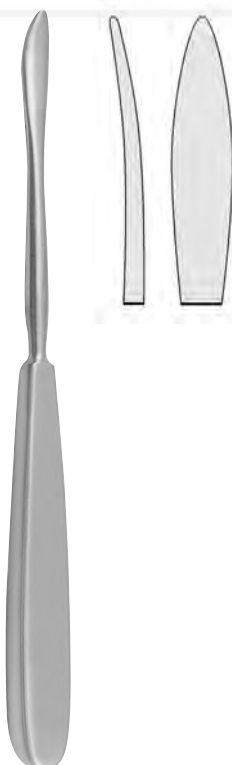

**LANGENBECK**  
20,0 cm, 8"  
193-520-08



**LANGENBECK**  
20,0 cm, 8"  
193-520-10



**ADSON**  
17,0 cm, 6<sup>3</sup>/<sub>4</sub>"



8 mm  
193-465-01

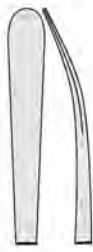

7 mm  
193-465-02



7 mm  
193-465-03



7 mm  
193-465-04



**KÖNIG**  
15,5 cm, 6"  
193-476-15

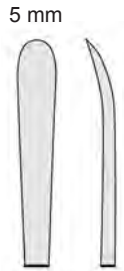

5 mm



**LAMBOTTE**  
21,0 cm, 8<sup>1</sup>/<sub>4</sub>"



10 mm  
193-477-10



15 mm  
193-477-15



20 mm  
193-477-20



25 mm  
193-477-25

12,5 mm



**FARABEUF**  
15,0 cm, 6"  
193-478-15



12,5 mm

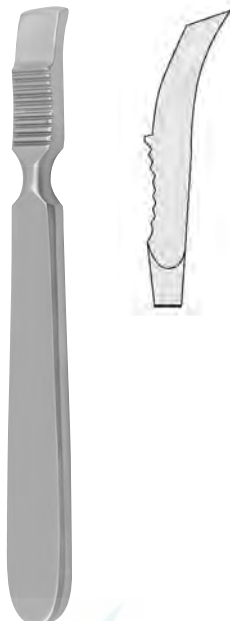

**FARABEUF**  
15,0 cm, 6"  
193-479-15

16,0 mm

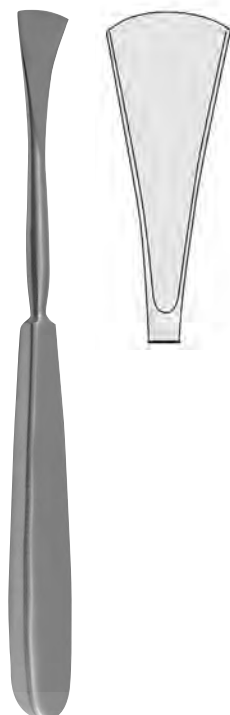

**LANGENBECK**  
19,0 cm, 7½"  
193-472-19

15,0 mm



**SEDILLOT**  
21,0 cm, 8¼"  
193-488-21



4 mm 193-480-04  
6 mm 193-480-06  
8 mm 193-480-08

**WILLIGER**  
16,0 cm, 6¼"



für Kinder  
for children  
para niños  
per bambini

**DOYEN**  
17,0 cm, 6¾"  
193-485-17



für Kinder  
for children  
para niños  
per bambini

**DOYEN**  
17,0 cm, 6¾"  
193-487-17



für Erwachsene  
for adults  
para adultos  
per adulti дп

**DOYEN**  
17,0 cm, 6¾"  
193-481-17



für Erwachsene  
for adults  
para adultos  
per adulti

**DOYEN**  
17,0 cm, 6¾"  
193-483-17

Flachmeißel, Hohlmeißel, Osteotome  
 Chisels, Gouges, Osteotomes  
 Cinceles, Gubias, Osteótomos  
 Scalpelli, Sgorbie, Osteotomi

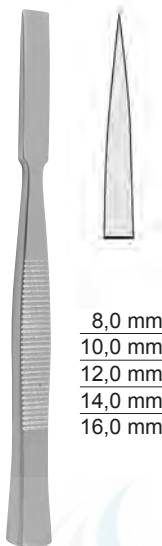

8,0 mm	<b>194-300-08</b>
10,0 mm	<b>194-300-10</b>
12,0 mm	<b>194-300-12</b>
14,0 mm	<b>194-300-14</b>
16,0 mm	<b>194-300-16</b>

13,5 cm, 5<sup>3</sup>/<sub>8</sub>"

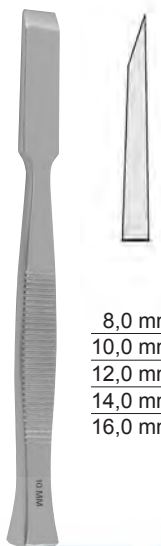

8,0 mm	<b>194-301-08</b>
10,0 mm	<b>194-301-10</b>
12,0 mm	<b>194-301-12</b>
14,0 mm	<b>194-301-14</b>
16,0 mm	<b>194-301-16</b>

13,5 cm, 5<sup>3</sup>/<sub>8</sub>"

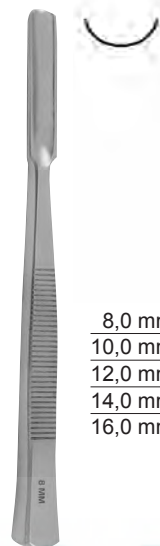

8,0 mm	<b>194-302-08</b>
10,0 mm	<b>194-302-10</b>
12,0 mm	<b>194-302-12</b>
14,0 mm	<b>194-302-14</b>
16,0 mm	<b>194-302-16</b>

13,5 cm, 5<sup>3</sup>/<sub>8</sub>"



3,0 mm	<b>194-334-03</b>
4,0 mm	<b>194-334-04</b>
5,0 mm	<b>194-334-05</b>
6,0 mm	<b>194-334-06</b>

**PARTSCH**  
13,5 cm, 5<sup>3</sup>/<sub>8</sub>"

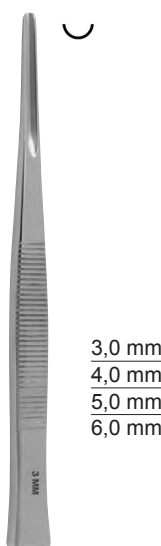

3,0 mm	<b>194-336-03</b>
4,0 mm	<b>194-336-04</b>
5,0 mm	<b>194-336-05</b>
6,0 mm	<b>194-336-06</b>

**PARTSCH**  
13,5 cm, 5<sup>3</sup>/<sub>8</sub>"



10,0 mm	<b>194-361-10</b>
15,0 mm	<b>194-361-15</b>
20,0 mm	<b>194-361-20</b>
25,0 mm	<b>194-361-25</b>

**STILLE**  
20,0 cm, 8"



10,0 mm	<b>194-360-10</b>
15,0 mm	<b>194-360-15</b>
20,0 mm	<b>194-360-20</b>
25,0 mm	<b>194-360-25</b>

**STILLE**  
20,0 cm, 8"

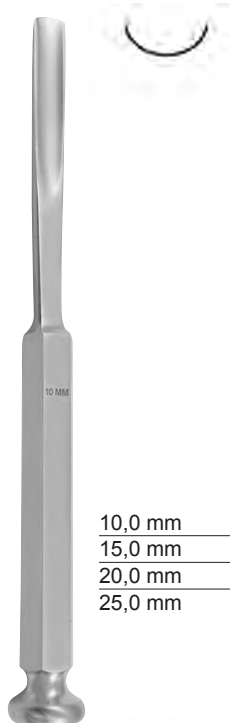

10,0 mm	<b>194-362-10</b>
15,0 mm	<b>194-362-15</b>
20,0 mm	<b>194-362-20</b>
25,0 mm	<b>194-362-25</b>

**STILLE**  
20,0 cm, 8"



4,0 mm	<b>194-318-04</b>
6,0 mm	<b>194-318-06</b>
8,0 mm	<b>194-318-08</b>
10,0 mm	<b>194-318-10</b>
12,0 mm	<b>194-318-12</b>
14,0 mm	<b>194-318-14</b>

**ALEXANDER**  
18,0 cm, 7"



4,0 mm	<b>194-319-04</b>
6,0 mm	<b>194-319-06</b>
8,0 mm	<b>194-319-08</b>
10,0 mm	<b>194-319-10</b>
12,0 mm	<b>194-319-12</b>
14,0 mm	<b>194-319-14</b>

**ALEXANDER**  
18,0 cm, 7"



6,0 mm	<b>194-350-06</b>
9,0 mm	<b>194-350-09</b>
13,0 mm	<b>194-350-13</b>
16,0 mm	<b>194-350-16</b>
19,0 mm	<b>194-350-19</b>
25,0 mm	<b>194-350-25</b>
32,0 mm	<b>194-350-32</b>

**SMITH-PETERSEN**  
20,0 cm, 8"



6,0 mm	<b>194-351-06</b>
9,0 mm	<b>194-351-09</b>
13,0 mm	<b>194-351-13</b>
16,0 mm	<b>194-351-16</b>
19,0 mm	<b>194-351-19</b>
25,0 mm	<b>194-351-25</b>
32,0 mm	<b>194-351-32</b>

**SMITH-PETERSEN**  
20,0 cm, 8"

Flachmeißel, Hohlmeißel, Osteotome, Hämmer  
 Chisels, Gouges, Osteotomes, Mallets  
 Cinceles, Gubias, Osteótomos, Martillos  
 Scalpelli, Sgorbie, Osteotomi, Martelli



9,0 mm	<b>194-352-09</b>
14,0 mm	<b>194-352-14</b>
16,0 mm	<b>194-352-16</b>
19,0 mm	<b>194-352-19</b>
25,0 mm	<b>194-352-25</b>

**SMITH-PETERSEN**  
20,0 cm, 8"



9,0 mm	<b>194-353-09</b>
14,0 mm	<b>194-353-14</b>
16,0 mm	<b>194-353-16</b>
19,0 mm	<b>194-353-19</b>
25,0 mm	<b>194-353-25</b>

**SMITH-PETERSEN**  
20,0 cm, 8"

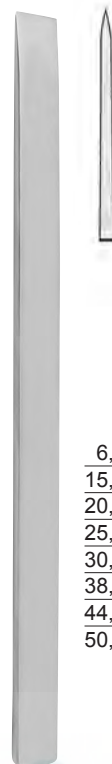

6,0 mm	<b>194-450-06</b>
15,0 mm	<b>194-450-15</b>
20,0 mm	<b>194-450-20</b>
25,0 mm	<b>194-450-25</b>
30,0 mm	<b>194-450-30</b>
38,0 mm	<b>194-450-38</b>
44,0 mm	<b>194-450-44</b>
50,0 mm	<b>194-450-50</b>

**LAMBOTTE**  
24,0 cm, 9 1/2"

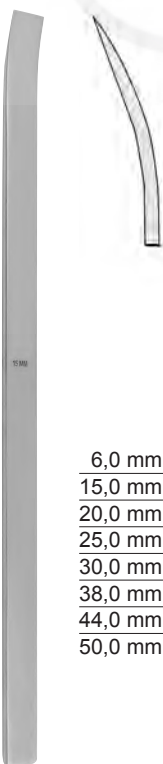

6,0 mm	<b>194-451-06</b>
15,0 mm	<b>194-451-15</b>
20,0 mm	<b>194-451-20</b>
25,0 mm	<b>194-451-25</b>
30,0 mm	<b>194-451-30</b>
38,0 mm	<b>194-451-38</b>
44,0 mm	<b>194-451-44</b>
50,0 mm	<b>194-451-50</b>

**LAMBOTTE**  
24,0 cm, 9 1/2"

Ø 30 mm  
220 g

Ø 22 mm  
200 g

Ø 45 mm  
300 g



**COLLIN**  
20,0 cm, 8"  
**191-132-20**



**PARTSCH**  
18,0 cm, 7"  
**191-145-18**

mit Bleifüllung  
lead filled head  
cabezal relleno de plomo  
testa di piombo



**BERGMANN**  
24,0 cm, 9 1/2"  
**191-201-24**

**Sterilisation**  
**Sterilization**  
**Esterilización**  
**Sterilizzazione**

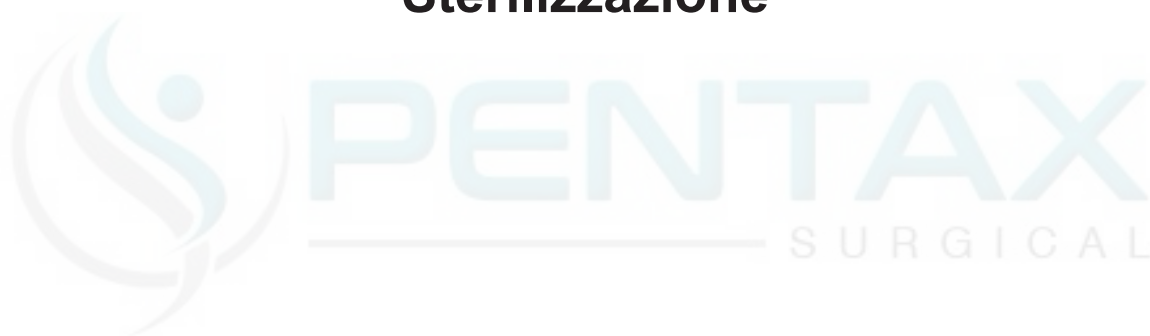



20,0 cm, 8"  
250-160-20



**CHEATTLE**  
27,0 cm, 10<sup>5</sup>/<sub>8</sub>"  
250-163-27

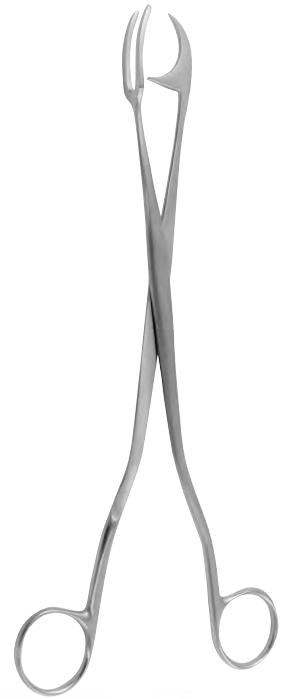

**ROGGE**  
23,0 cm, 9"  
250-164-23



**MAYO**  
14,0 cm, 5<sup>1</sup>/<sub>2</sub>"  
250-151-14

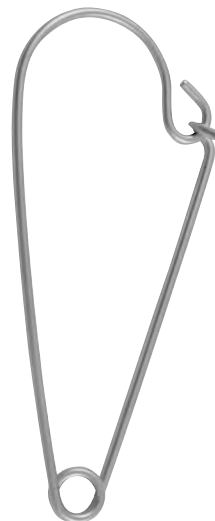

**BUNT**  
12,0 cm, 4<sup>3</sup>/<sub>4</sub>"  
250-154-12



Ø 75 x 130 mm	<b>250-142-06</b>
Ø 75 x 175 mm	<b>250-142-07</b>
Ø 100 x 175 mm	<b>250-142-08</b>
Ø 100 x 200 mm	<b>250-142-09</b>

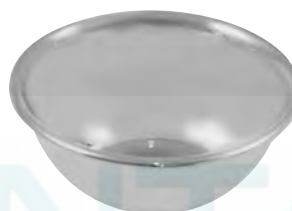

Ø 40,0 mm	<b>250-130-04</b>
Ø 60,0 mm	<b>250-130-06</b>
Ø 80,0 mm	<b>250-130-08</b>
Ø 100,0 mm	<b>250-130-10</b>
Ø 120,0 mm	<b>250-130-12</b>
Ø 150,0 mm	<b>250-130-15</b>



165 x 55 mm	0,75 l	<b>250-133-00</b>
175 x 70 mm	1,00 l	<b>250-133-10</b>
225 x 100 mm	2,00 l	<b>250-133-20</b>
240 x 95 mm	2,75 l	<b>250-133-30</b>
260 x 120 mm	4,00 l	<b>250-133-40</b>
290 x 100 mm	5,00 l	<b>250-133-50</b>
315 x 150 mm	5,50 l	<b>250-133-60</b>
325 x 135 mm	8,00 l	<b>250-133-70</b>
360 x 165 mm	12,00 l	<b>250-133-80</b>
415 x 150 mm	14,00 l	<b>250-133-90</b>



170 mm	<b>250-140-17</b>
250 mm	<b>250-140-25</b>
275 mm	<b>250-140-27</b>

Schalen  
Trays  
Bandejas  
Bacinelle



**250-300-00**  
Ø 65 x 17 mm  
Außen- und Innendose  
Exterior and interior box  
Caja exterior e interior  
Scatola esterna es interiore

**250-300-01**  
Ø 62 x 13 mm  
Innendose allein  
Interior box only  
Caja interior, suelta  
Scatola interiore sola



200 x 150 x 25 mm	<b>250-200-01</b>
260 x 180 x 30 mm	<b>250-200-02</b>
300 x 220 x 30 mm	<b>250-200-03</b>
350 x 220 x 40 mm	<b>250-200-04</b>
220 x 170 x 50 mm	<b>250-200-05</b>
280 x 200 x 50 mm	<b>250-200-06</b>
320 x 240 x 50 mm	<b>250-200-07</b>
370 x 270 x 50 mm	<b>250-200-08</b>
420 x 320 x 50 mm	<b>250-200-09</b>



25 ccm  
**250-310-25**



50 ccm  
**250-310-50**



Bürstenspender für 10 Bürsten  
Brush dispenser for 10 brushes  
Distribuidor de cepillos para 10 cepillos  
Distributore per 10 spazzole  
260 x 155 x 65 mm  
**250-800-01**

Bürstenspender für 20 Bürsten  
Brush dispenser for 20 brushes  
Distribuidor de cepillos para 20 cepillos  
Distributore per 20 spazzole  
270 x 240 x 65 mm  
**250-800-02**

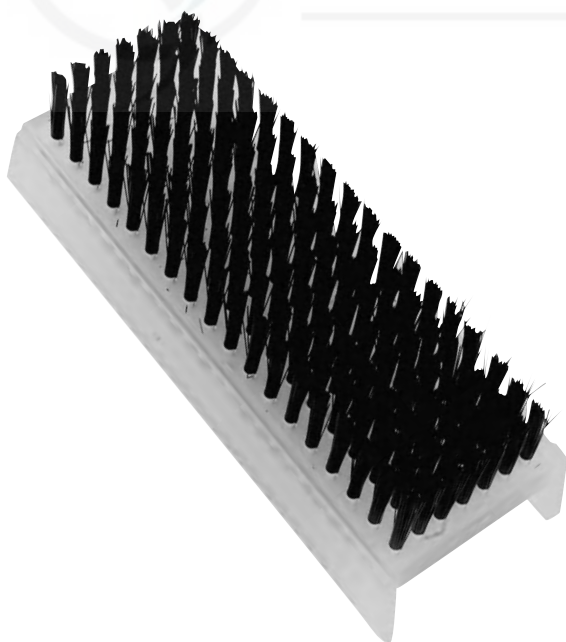

**250-800-10**

mehr als 400x autoklavierbar  
more than 400 times autoclavable  
esterilizable más de 400 veces en autoclave  
sterilizzabile più di 400 volte in autoclave

# *THANK YOU*



## CONTACT US



[www.pentaxsurgical.com](http://www.pentaxsurgical.com)



[pentaxsurgical@gmail.com](mailto:pentaxsurgical@gmail.com)  
[info@pentaxsurgical.com](mailto:info@pentaxsurgical.com)



+92-328 01 66 200

Visit Alibaba Site:

